

# Comfort 220.2, 250.2, 252.2, 250.2 speed

Operator system for Garage Doors

GB



Installation and Operating Instructions

**Marantec** 

Door operators → automatically the best choice

[www.marantec.com](http://www.marantec.com)

## 1. Meaning of symbols

### Advice



#### **Caution!** **Danger of personal injury!**

The following safety advice must be observed at all times so as to avoid personal injury!



#### **Attention!** **Danger of material damage!**

The following safety advice must be observed at all times so as to avoid material damage!



#### **Advice / Tip**



#### **Check**



#### **Reference**

### Type plate

Type: _____
Art. No.: _____
Product No.: _____

## 2. Table of contents

<b>1.</b>	<b>Meaning of symbols</b>	<b>2</b>
<b>2.</b>	<b>Table of contents</b>	<b>2</b>
<b>3.</b>	<b>General safety advice</b>	<b>3</b>
<b>4.</b>	<b>Product overview</b>	<b>4</b>
4.1	Comfort 220.2, 250.2, 252.2, 250.2 speed supply package	4
4.2	Door variations	6
<b>5.</b>	<b>Preparation for mounting</b>	<b>6</b>
<b>6.</b>	<b>Installation</b>	<b>7</b>
6.1	Installing the motor unit and drive boom	7
6.2	Installation on the door	8
6.3	Installation on the ceiling	9
6.4	Lighting, signal light connection (optional)	9
6.5	Release	10
6.6	Connection of control elements	11
<b>7.</b>	<b>Hand transmitter</b>	<b>12</b>
7.1	Operation and accessories	12
7.2	Hand transmitter coding	13
<b>8.</b>	<b>Initial operation</b>	<b>14</b>
8.1	Connecting the operator system	14
8.2	Overview of the control unit	14
8.3	Overview of the display functions	15
8.4	Express programming	15
8.5	Function test	17
<b>9.</b>	<b>Extended operator functions</b>	<b>18</b>
9.1	Programming structure for extended operator functions (Example for Level 2, Menu 2)	18
9.2	General overview of the programmable functions	19
9.3	Functions overview for the levels	21
<b>10.</b>	<b>Messages</b>	<b>31</b>
10.1	Malfunctions without error messages	31
10.2	Malfunctions with error messages	32
<b>11.</b>	<b>Attachment</b>	<b>34</b>
11.1	Technical Data for Comfort 220.2, 250.2, 252.2, 250.2 speed	34
11.2	Manufacturer's Declaration	35
11.3	EC Declaration of Conformity	35

## 3. General safety advice



### Please read carefully!

#### Target group

This operator system may only be installed, connected and put into operation by qualified and trained professionals!

Qualified and trained specialist personnel are persons

- who have knowledge of the general and special safety regulations,
- who have knowledge of the relevant electro-technical regulations,
- with training in the use and maintenance of suitable safety equipment,
- who are sufficiently trained and supervised by qualified electricians,
- who are able to recognise the particular hazards involved when working with electricity,
- with knowledge regarding applications of the EN 12635 standard (installation and usage requirements).

#### Warranty

For an operations and safety warranty, the advice in this instruction manual has to be observed. Disregarding these warnings may lead to personal injury or material damage. If this advice is disregarded, the manufacturer will not be liable for damages that might occur.

Batteries, fuses and bulbs are excluded from warranty.

To avoid installation errors and damage to the door and operator system, it is imperative that the installation instructions are followed. The system may only be used after thoroughly reading the respective mounting and installation instructions.

The installation and operating instructions are to be given to the door system user, who must keep them safe. They contain important advice for operation, checks and maintenance.

This item is produced according to the directives and standards mentioned in the Manufacturer's Declaration and in the Declaration of Conformity. The product has left the factory in perfect condition with regard to safety.

Power-operated windows, doors and gates must be checked by an expert (and this must be documented) before they are put into operation and thereafter as required, but at least once a year.

#### Correct use

The operator system is designed exclusively for opening and closing garage doors.

The operator must be used in a dry place.

The maximum push and pull force must be observed.

#### Door requirements

The door must:

- stand still alone (by balance of springs),
- run smoothly.

**Beside the advice in these instructions, please observe the general safety and accident prevention regulations!**  
**Our sales and supply terms and conditions are effective.**

#### Information on installing the operator system

- Ensure that the door is in good mechanical condition.
- Ensure that the door can stop in any position.
- Ensure that the door can be easily moved in the OPEN and CLOSE directions.
- Ensure that the door opens and closes properly.
- Remove all unnecessary components from the door (e.g. cables, chains, brackets).
- Render any installations inoperable that will no longer be needed after the operator system has been installed.
- Before commencing cabling works it is very important to disconnect the operator system from the electricity supply. Ensure that the electricity supply remains disconnected throughout the cabling works.
- Adhere to the local protection regulations.
- Lay the electricity supply cables and control cables; these MUST be laid separately. The controls voltage is 24 V DC.
- Install the operator system with the door in the CLOSED position.
- Install all the impulse transmitters and control devices (e.g. remote control buttons) within sight of the door and at a safe distance from the moving parts of the door. A minimum installation height of 1.5 m must be observed.
- Permanently fix the warning signs, which advise of the danger of becoming trapped, at conspicuous locations.
- Ensure that no part of the door extends across public footways or roads when the installation is complete.

#### Information on commissioning the operator system

After initial operation, the persons responsible for operating the door system, or their representatives must be familiarised with the use of the system.

- Make sure that children cannot access the door control unit.
- Before moving the door, make sure that there are neither persons nor objects in the operating range of the door.
- Test all existing emergency command devices.
- Never insert your hands into a running door or moving parts.
- Pay attention to any parts of the door system that could cause crushing or shearing damage or accidents. The EN 13241-1 regulations must be observed.

#### Information on servicing the operator system

To ensure proper operation, the following items must be checked regularly and repaired if necessary.

Before any works to the door system are undertaken, the operator system must be disconnected from the mains.

- Check once a month to ensure that the operator system reverses if the door encounters an obstacle. Depending on the operational direction of the door, place a 50 mm high/wide obstacle in its path.
- Check the settings of the OPEN and CLOSE automatic cut-out function.
- Check all movable parts of the door and operator system.
- Check the door system for signs of wear or damage.
- Check whether the door can be easily moved by hand.

#### Information on cleaning the operator system

Never use water jets, high pressure cleaners, acids or bases for cleaning.

## 4. Product overview

### 4.1 Comfort 220.2, 250.2, 252.2, 250.2 speed supply package

#### Standard package

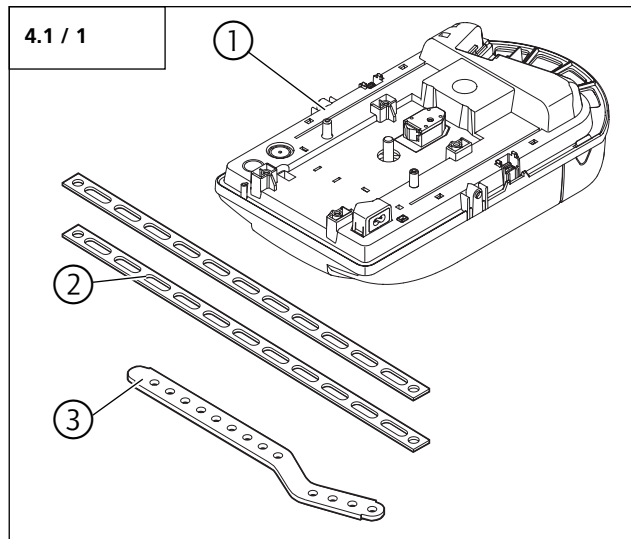

- 1 Comfort 220.2, 250.2, 252.2, 250.2 speed motor unit
- 2 Support plate
- 3 Door link

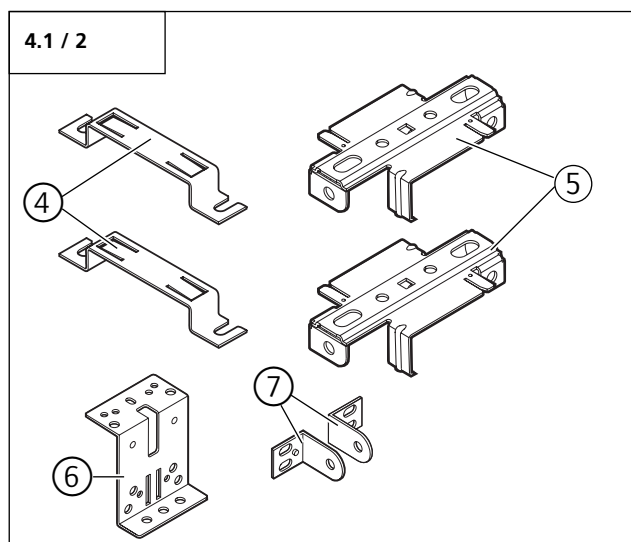

- 4 Boom clamps (2x)
- 5 Suspension cramps (2x)
- 6 Door connector element
- 7 Door link bracket (2x)

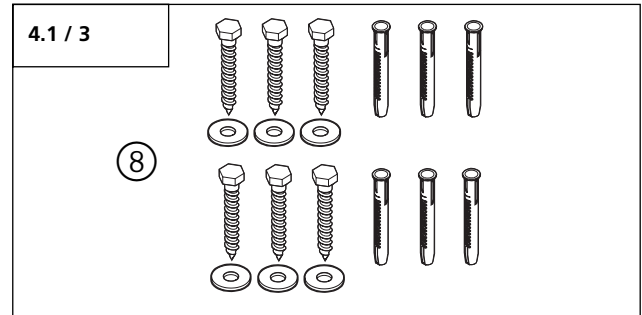

- 8 Fixing materials for the boom

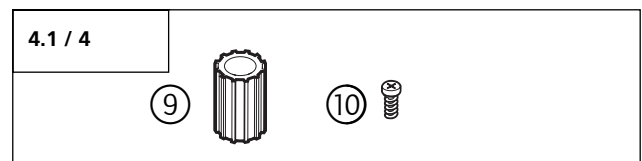

- 9 Adapter sleeve
- 10 Screw 4.0 x 10

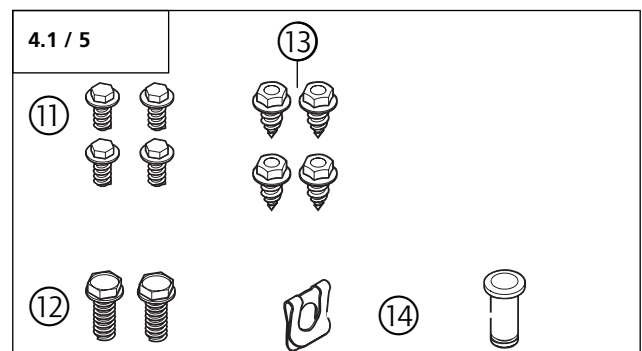

- 11 Screw 6 x 14 (4x)
- 12 Hexagonal head screw M6 x 20 (2x)
- 13 Self-tapping screw 6.3 x 16 (4x)
- 14 Bolt A8 with locking plate

## 4. Product overview

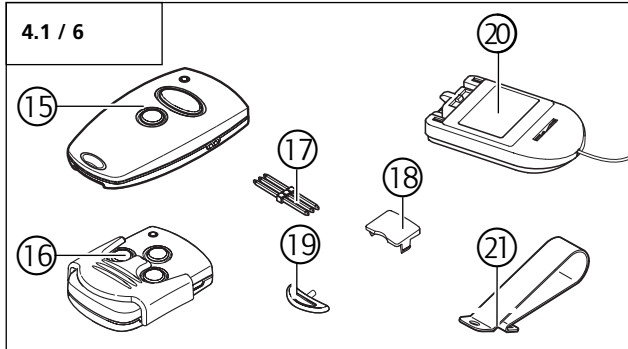

- 15 Mini hand transmitter
- 16 Micro hand transmitter (only in case of Comfort 250.2, Comfort 252.2 and Comfort 250.2 speed – subject to country-specific alterations)
- 17 Transmission plug
- 18 Sun visor clip flap
- 19 Attachment piece
- 20 Modular antenna
- 21 Sun visor clip

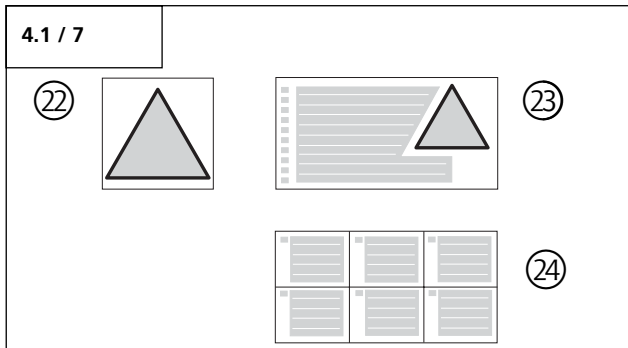

- 22 Warning sign for disengaging
- 23 Warning sticker
- 24 Sticker for express programming

In addition to the components included in the standard package, the following accessories are required for the installation:

- drive boom

### Drive booms

The motor unit can be combined with various types of drive boom.

#### Rail type 1

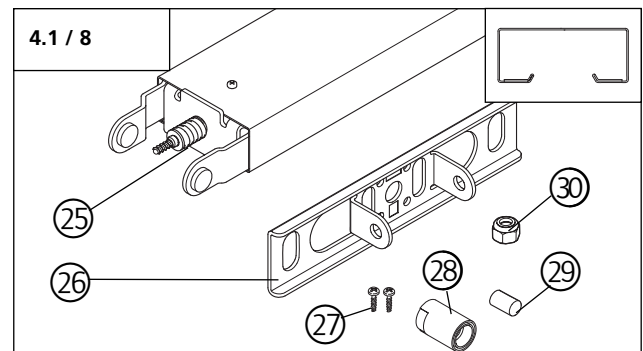

- 25 Operator rail
- 26 Lintel joining plate, rail type 1
- 27 Screw B4 4.2 x 13 (2x)
- 28 Securing sleeve, short
- 29 Bolt 8 x 12.5
- 30 M6 nut, self-locking

#### Rail type 2

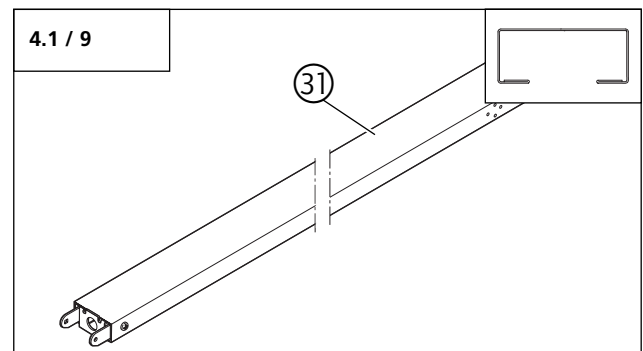

- 31 Operator rail

## 4. Product overview

### 4.2 Door variations

The standard package with the appropriate operator boom is suitable for the following types of door.

#### Swing out retractable up-and-over door

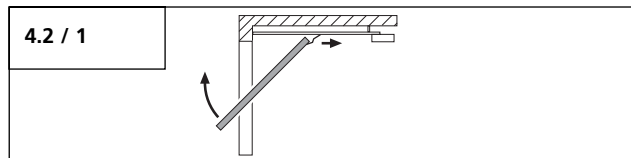

#### Sectional door, up to 3 m wide

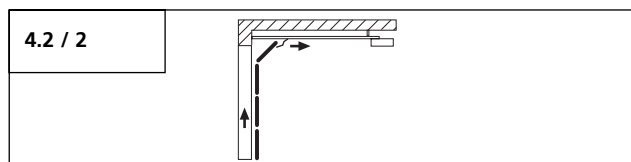

Special accessories are necessary for the following door type.

#### Non-swing out retractable up-and-over door

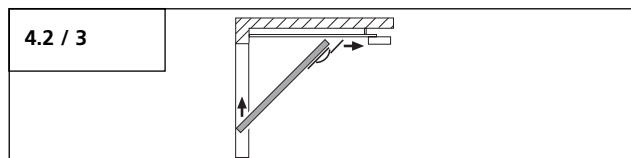

#### Sectional door, greater than 3 m wide

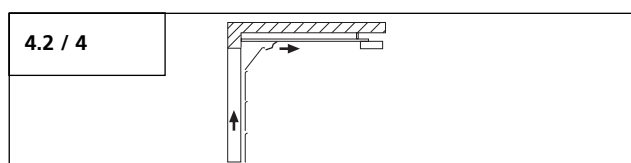

## 5. Preparation for mounting



### Attention!

In order to guarantee correct mounting, carry out the following checks before installing.

#### Supply package

- Check the package to ensure that all the parts are included.
- Check that you have all the additional components that are necessary for your particular installation requirements.

#### Garage

- Check whether your garage has a suitable mains connection and a mains disconnection facility.

#### Door system



### Attention!

For garages without a second entrance: the garage door must be fitted with an emergency release system to allow access to the garage if a fault occurs.

If a release kit is used:

- Check that the door locks are functioning correctly. The door locks may not be disabled under any circumstances.

If a release kit is **not** used:

- Dismantle or disable the door locks.
- Check that the door to be operated fulfils the following conditions:
  - the door must be easily moveable by hand,
  - the door should automatically remain in every position into which it was moved.



### Reference:

When using and installing accessories, always observe the specific instructions included with the equipment.

## 6. Installation

### 6.1 Installing the motor unit and drive boom

#### Installation, rail type 1

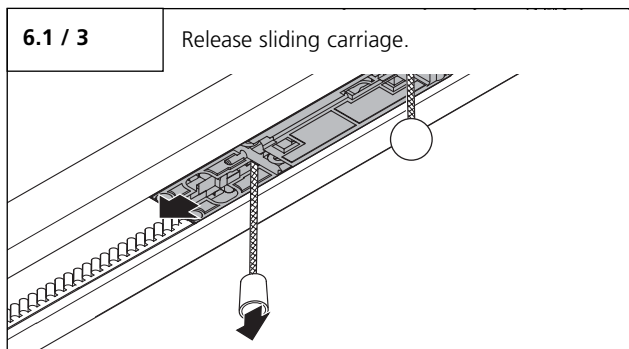
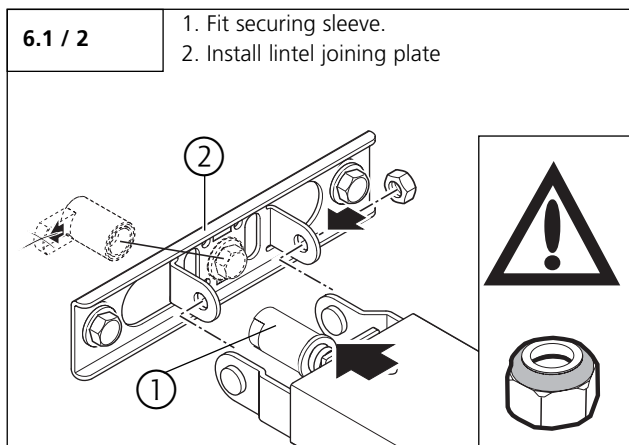
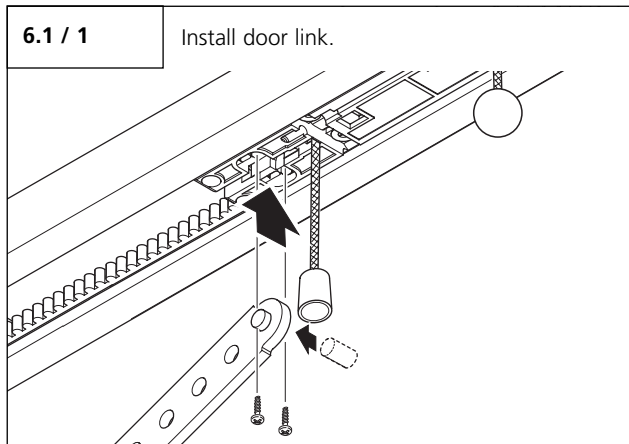

#### Attention!

The drive boom (C) must be carefully mounted on the motor unit (F). Do not use force, as this could damage the gear teeth!

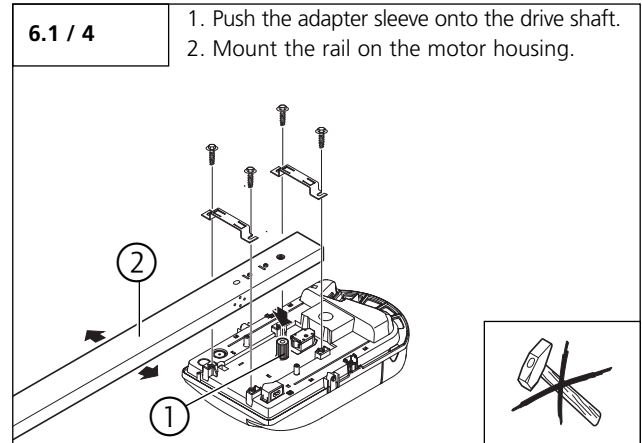

#### Installation, rail type 2

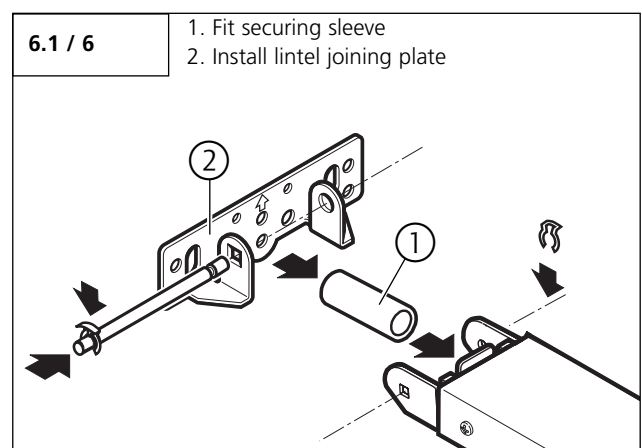
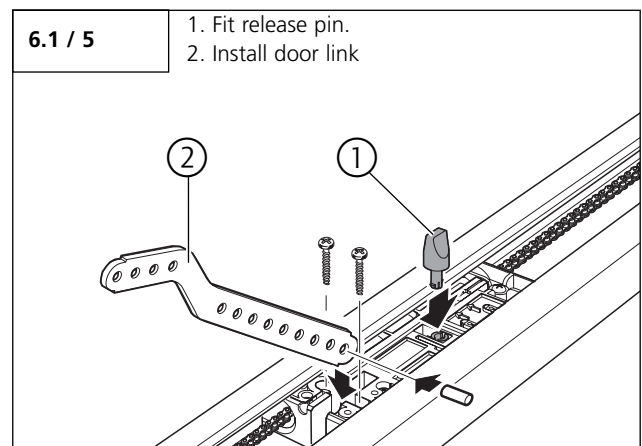



## 6. Installation

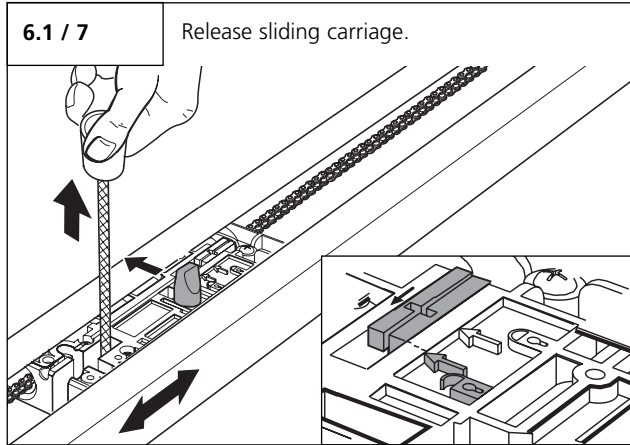

### Attention!

The drive boom (C) must be carefully mounted on the motor unit (F). Do not use force, as this could damage the gear teeth!

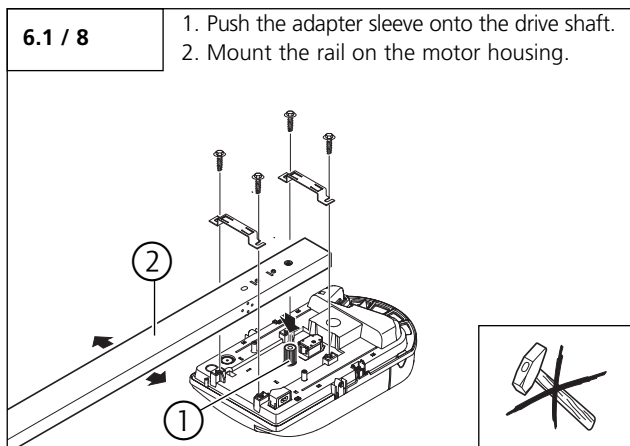

## 6.2 Installation on the door



### Caution!

The drive system must be prevented from falling before it has been properly fixed.



### Attention!

In order to ensure that the door balance is correct:

- the lintel joining plate for the operator rail must be mounted at the mid point, above the door connector,
- at the highest point reached by the door, the upper edge of the door leaf must be 10 - 50 mm below the horizontal underside of the operator rail.

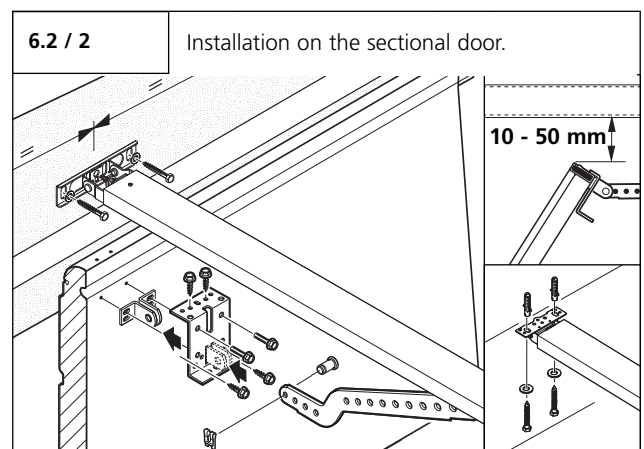
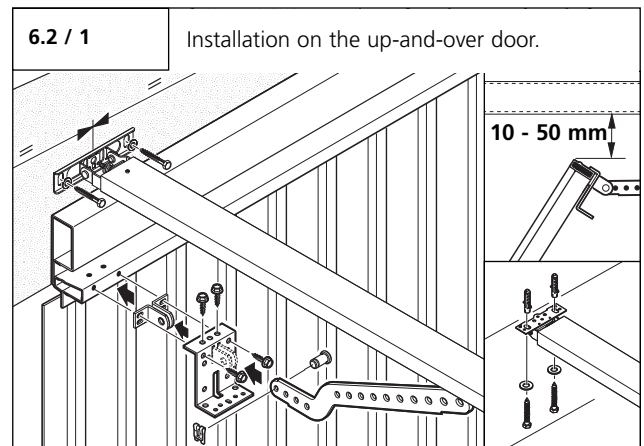



## 6. Installation

### 6.3 Installation on the ceiling

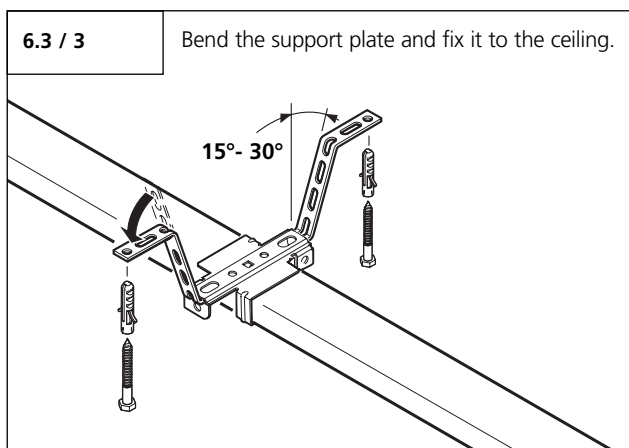
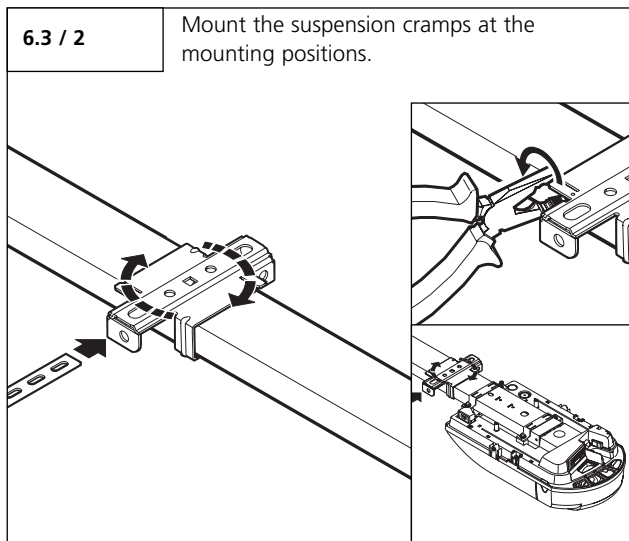
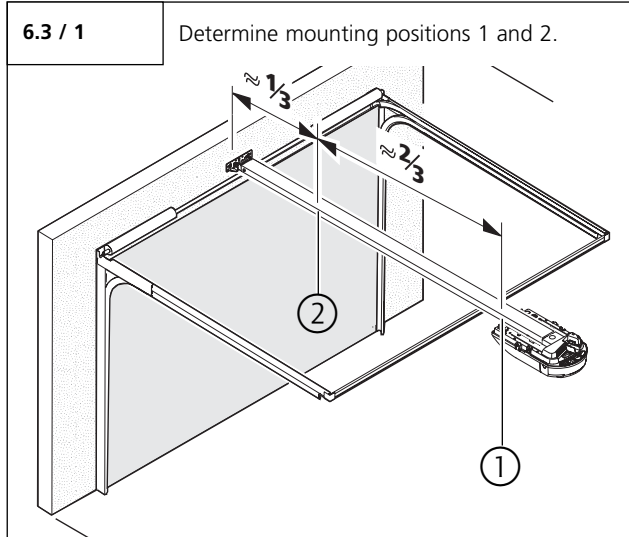

### 6.4 Lighting, signal light connection (optional)

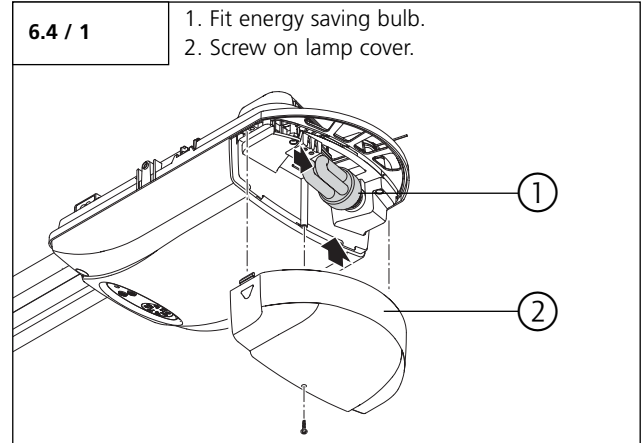

#### Connection of signal light (optional)

The connection of a signal light is only possible with a signal light relay (not included in the scope of delivery).



#### Attention!

To avoid damaging the cable insulation, the cable must be laid in such a way that it does not come into contact with the illuminant in the motor unit.

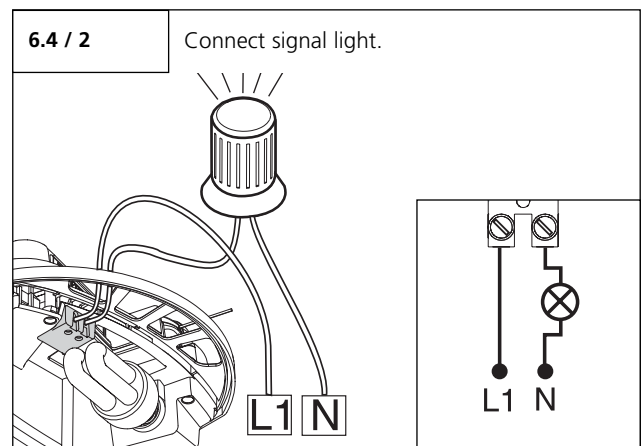

#### Reference:

The programming of the signal light is described in level 1, menu 7 and in level 3, menu 7.

## 6. Installation

### 6.5 Release



#### Caution!

- Uncontrolled door movements may occur when the release function is activated:
- if the door springs are weak or broken;
- or if the door is not balanced.

When opening the door manually, the carriage can collide with the motor unit.

If the door has been released, it should only be moved at a moderate speed!

- Construct a physical barrier to limit the extent of the door travel in the opening direction.
- Check that the release pull cord is at a minimum height of 1.8 m.
- Attach the "release warning sign" to the release pull cord.

#### Rail type 1

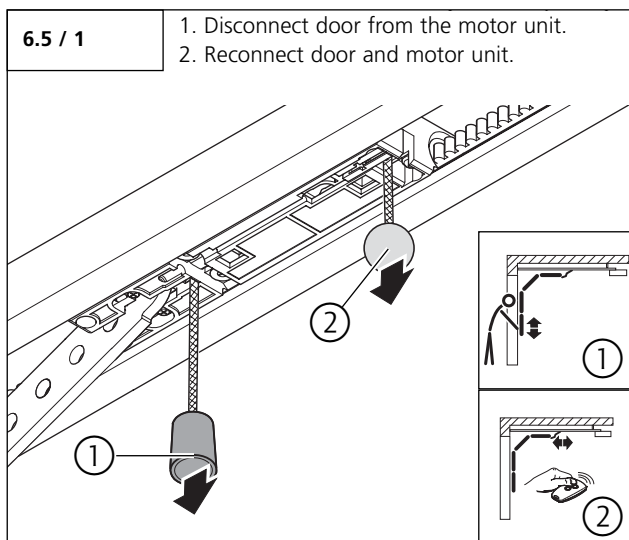

#### Rail type 2

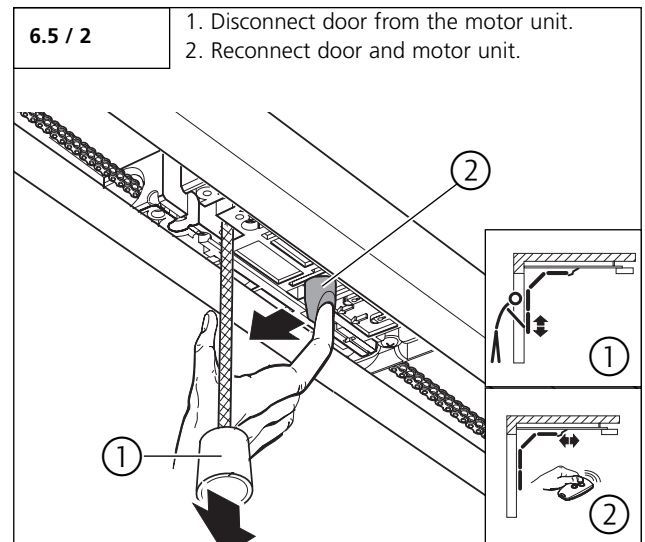

## 6. Installation

### 6.6 Connection of control elements



#### Caution!

Danger of electric shock:  
Before any cabling works begin, it must be ensured that the cables are disconnected from the power supply. During cabling works, it must be ensured that the cables remain disconnected from the power supply at all times (e.g. prevent reconnection).



#### Attention!

In order to avoid damaging the controls:

- The local safety regulations must be complied with at all times.
- It is very important that mains cables are laid separately from control cables.
- The controls voltage must be 24 V DC.
- If external voltages are applied at terminals XP020, XB10 or XB01, the entire electronic system will be destroyed.
- Only potential-free normally open contacts may be connected to terminals 1 and 2 (XB01).
- The shorting plug should never be plugged into the XP020 system socket!

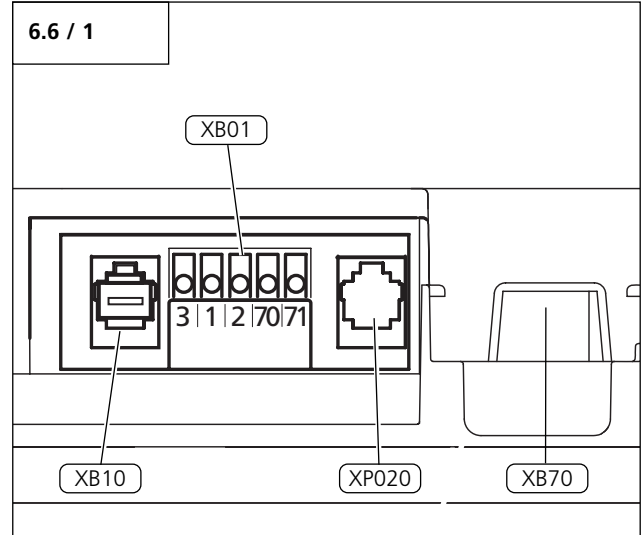

Label	Type / function	
XB01	Connection of external control elements without system cabling and two-wire photocell	6.6 / 2, 9.3 / Level 5 / Menu 1
XB10	Connection of external control elements with system cabling	-
XP020	Connection of system photocell or adapter cable for modular antenna	9.3 / Level 8
XB70	Connection of modular antenna	8.1



#### Reference:

When installing external control elements, or safety and signal equipment, the relevant instructions must be observed.



#### Advice:

Before connecting a control element to the terminals with system sockets, the corresponding shorting plug must first be removed.

## 6. Installation

### Terminal XB01

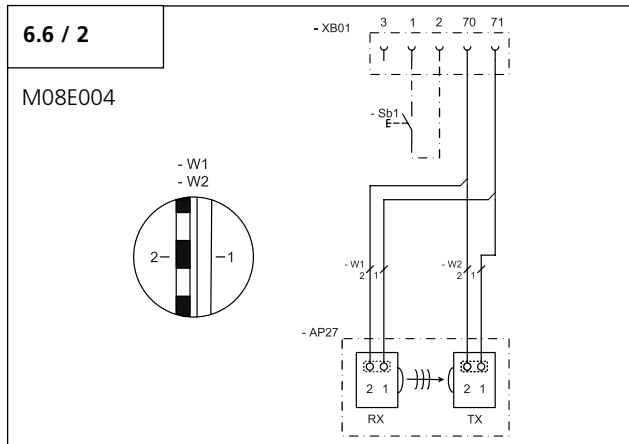

Label	Type / function
1	GND (0 V)
2	Impulse
3	24 V DC (max. 50 mA)
70	GND
70 + 71	Two-wire photocell
RX	Receiver for the two-wire photocell
Sb1	External impulse button (if applicable)
TX	Transmitter for the two-wire photocell



#### Advice:

If a photocell is to be connected, it must be installed before the express programming procedure is carried out. The photocell will only be recognised automatically by the controls if this is the case. Otherwise the photocell must be programmed after installation.

## 7. Hand transmitter

### 7.1 Operation and accessories



#### Caution!

- Children are not allowed to operate the hand transmitters!
- Before operating the hand transmitter, make sure that there are neither persons nor objects in the operating range of the door.

#### 7.1 / 1

Overview.

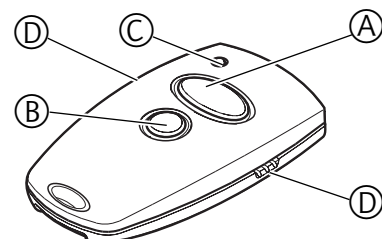

- A Operating button - large
- B Operating button - small
- C Battery - transmission control light
- D Transmission socket
- E Reverse side of the hand transmitter
- F Battery 3V CR 2032

#### 7.1 / 2

Replace battery.

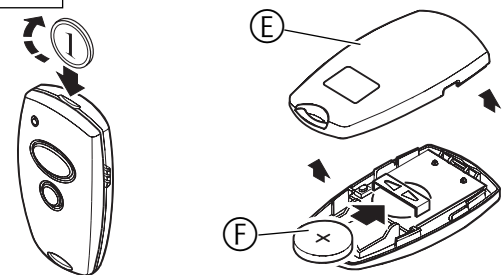

#### 7.1 / 3

Accessory sun visor clip.

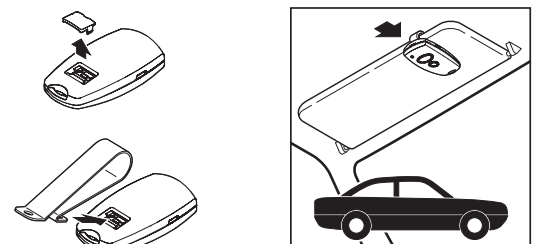

## 7. Hand transmitter

### 7.2 Hand transmitter coding

#### 7.2.1 Transfer the coding

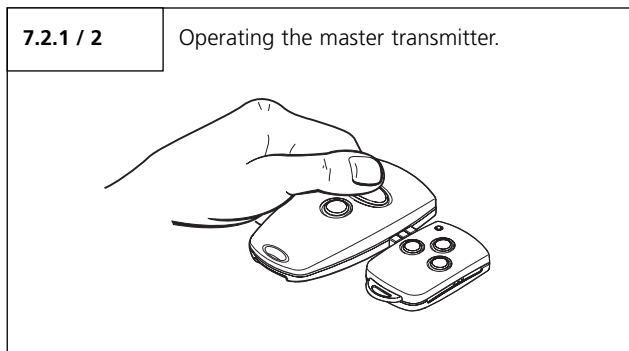
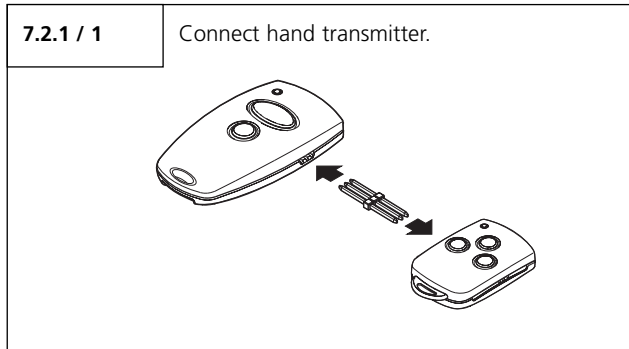

- Actuate the master transmitter and hold the button. The transmitter LED lights up.

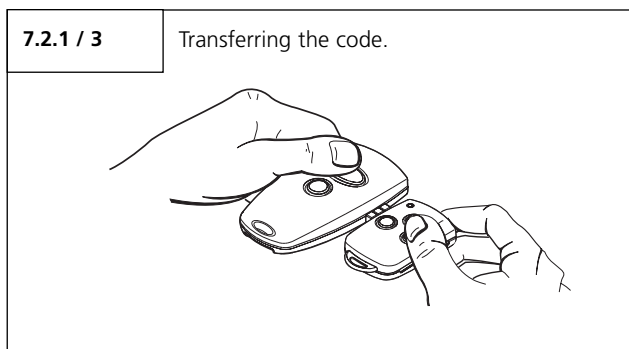

- Whilst keeping the button on the master transmitter depressed, press the desired button on the other hand transmitter. The LED flashes.

After 1 - 2 seconds, the LED on the newly programmed transmitter lights up permanently. The programming procedure is complete.

- Remove the transmission plug.

#### 7.2.2 Change coding

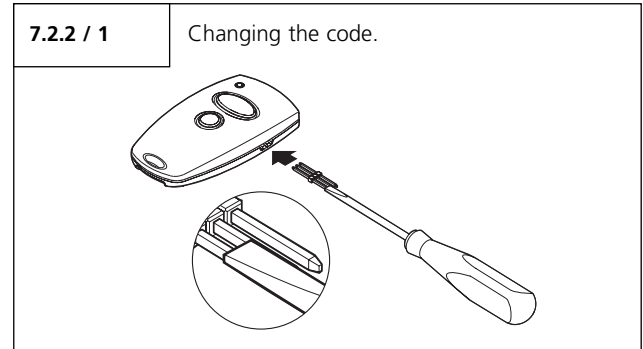

- Connect one end of the transmission plug to the hand transmitter.
- At the free end of the transmission plug, short-circuit one of the outer pins with the centre pin adjacent to it (e.g. using a screw driver).
- Press the desired button on the hand transmitter. A new code is then generated by the integrated random coding facility. The LED flashes quickly.

As soon as the LED lights up permanently, the hand transmitter has been programmed with a new code. The button can then be released and the transmission plug removed.



#### **Advice:**

- After the hand transmitter has been re-programmed, the operator system must also be re-programmed to respond to the new code.
- For multi-channel transmitters, the programming process must be carried out for each button separately.

## 8. Initial operation

### 8.1 Connecting the operator system

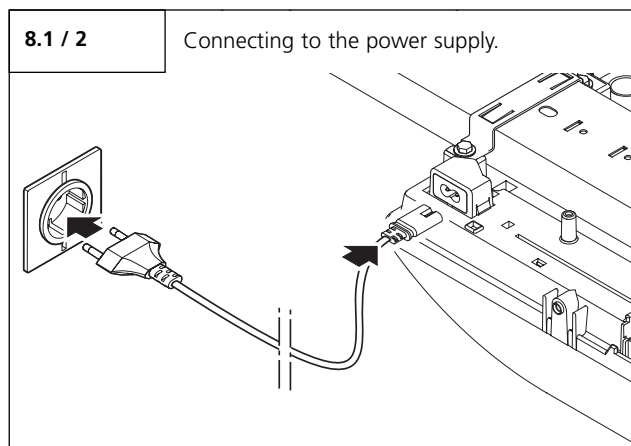
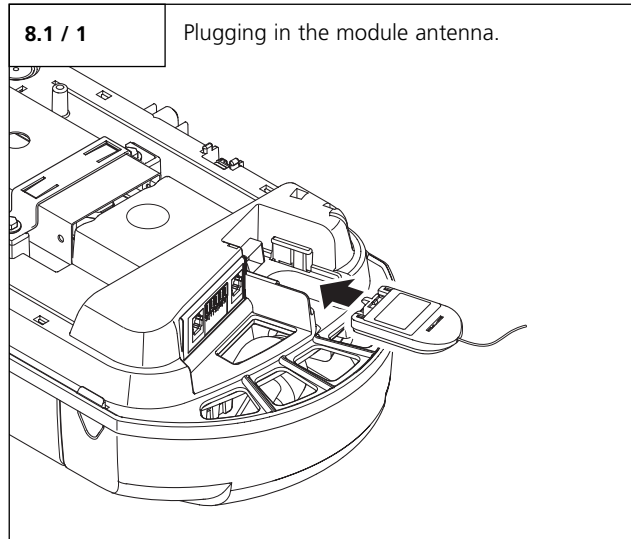

### 8.2 Overview of the control unit

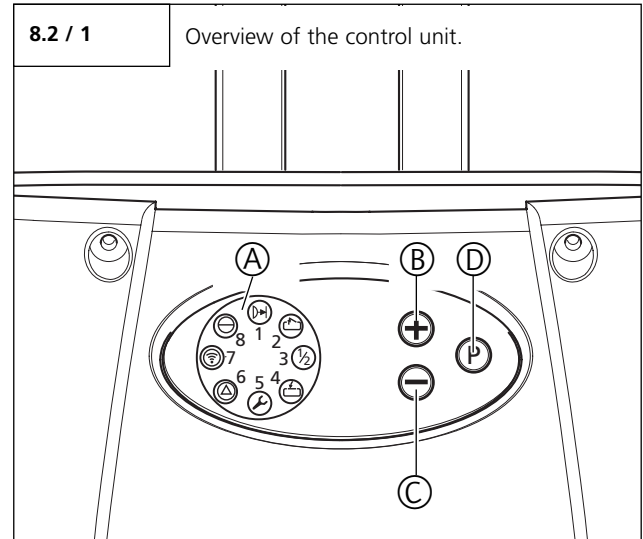











#### Operating elements



Label	Type / function	
A	Carousel display	8.3
B	OPEN button (+) (e.g. to drive the door to the OPEN position or to increase parameters when programming)	-
C	CLOSE button (-) (e.g. to drive the door to the CLOSED position or to decrease parameters when programming)	-
D	Button (p) (e.g. to switch to programming mode or to save parameters)	-

## 8. Initial operation

### 8.3 Overview of the display functions

#### LED displays in operating mode

	Photocell or the CESD has been interrupted
	Door moving towards OPEN position
	Door in OPEN position
	Door is at intermediate position
	Door moving towards CLOSED position
	Door in CLOSED position
	Reference point is switched
	Permanent actuation of an external control element
	Remote control is actuated
	Ready for operation

Legend:	
LED off	○
LED on	●
LED flashes slowly	
LED pulses	
LED flashes quickly	
Factory default setting	
Not possible	-

### 8.4 Express programming



#### Advice:

For proper initial operation of the operator system, the express programming procedure must be carried out.

This applies for the initial operation and after resetting.

#### Preconditions

The following conditions must be assured before express programming can commence:

- the door must be in the CLOSED end position.
- the carriage must be connected up.



#### Advice:

When programming the OPEN and CLOSED door positions, the reference point must be passed.

The controls are programmed using the plus (+), minus (-) and (P) buttons.

If no buttons are pressed within 120 seconds while in programming mode, the controls revert to operating mode. A corresponding message is displayed.













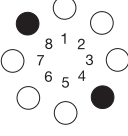

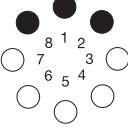

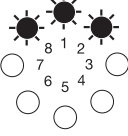

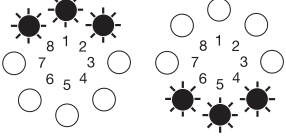

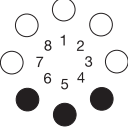
#### Reference:

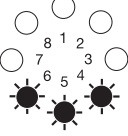
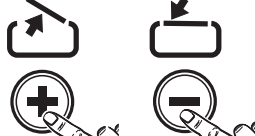
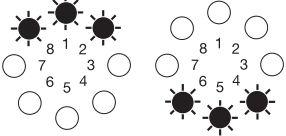
The messages are explained in Section 10.

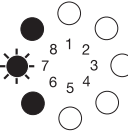
- Carry out the express programming according to the following procedure.

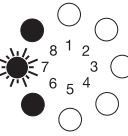

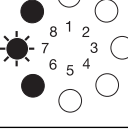
## 8. Initial operation

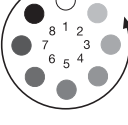
 <p>Operating mode</p>	<p>1x &gt;2s &lt;10s</p> 	<p><b>Start express programming / Programme the door OPEN end position</b></p>	
		<p>Drive the door to the OPEN position</p>	
		<p>Correct the OPEN door position using (+) and (-)</p>	
	<p>1x &lt;1s</p> 	<p><b>Save the OPEN door position / Programme the CLOSED door position</b></p>	
		<p>Drive the door to the CLOSED position</p>	
		<p>Correct the CLOSED door position using (+) and (-)</p>	
	<p>1x &lt;1s</p> 	<p><b>Save the CLOSED door position / Programme the remote control</b></p>	
		<p>Press the hand transmitter button</p>	
		<p>Release the hand transmitter button</p>	
	<p>1x &lt;1s</p> 	<p><b>Save the remote control settings / End the express programming procedure</b></p>	

## 8. Initial operation

### 8.5 Function test

#### 8.5.1 Learning run for determining the driving power



##### Check:





After express programming and after making changes to the programming menu, the following learning runs and checks must be carried out.

The operator system determines the maximum required driving power during the first two runs after setting the end positions of the door.

- Operate the operator system (with the door coupled) to drive the door once from the CLOSED position to the OPEN position and back to the CLOSED position without interruption.

During this learning run, the operator system determines the maximum push and pull forces and the reserve power required to move the door.

##### Test:

1.		After pressing the (+) button: The door must open and travel to the saved OPEN end position.
2.		After pressing the (-) button: The door must close and travel to the saved CLOSED end position.
3.		After pressing the hand transmitter button: The operator system must move the door in either the OPEN or CLOSE direction.
4.		After pressing the hand transmitter button while the operator system is running: The operator system must stop.
5.		When the button is pressed again, the operator system moves in the opposite direction.

#### 8.5.2 Checking the automatic cut-out



##### Caution!

The automatic cut-out must be correctly programmed for the CLOSE and OPEN directions to prevent damage to persons or property.

##### Automatic cut-out, OPENING

For drive systems where the door has openings in the door wing (diameter of opening > 50 mm):

- Apply a load of 20 kg to the middle of the lower edge of the door whilst the door is running.

**The door must stop immediately.**

##### Automatic cut-out, CLOSING

- Place a 50 mm high obstacle on the ground.
- Drive the door towards the obstacle.

**The drive system must stop and reverse when it comes into contact with the obstacle.**



##### Advice:

The parameter settings are still saved if the power supply is disconnected. Only a reset causes the driving power settings for the OPEN and CLOSE directions to revert to the factory settings.

##### Legend:

LED off	○
LED on	●
LED flashes slowly	☼
LED pulses	☼
LED flashes quickly	☼
Factory default setting	
Not possible	-

## 9. Extended operator functions

### 9.1 Programming structure for extended operator functions (Example for Level 2, Menu 2)

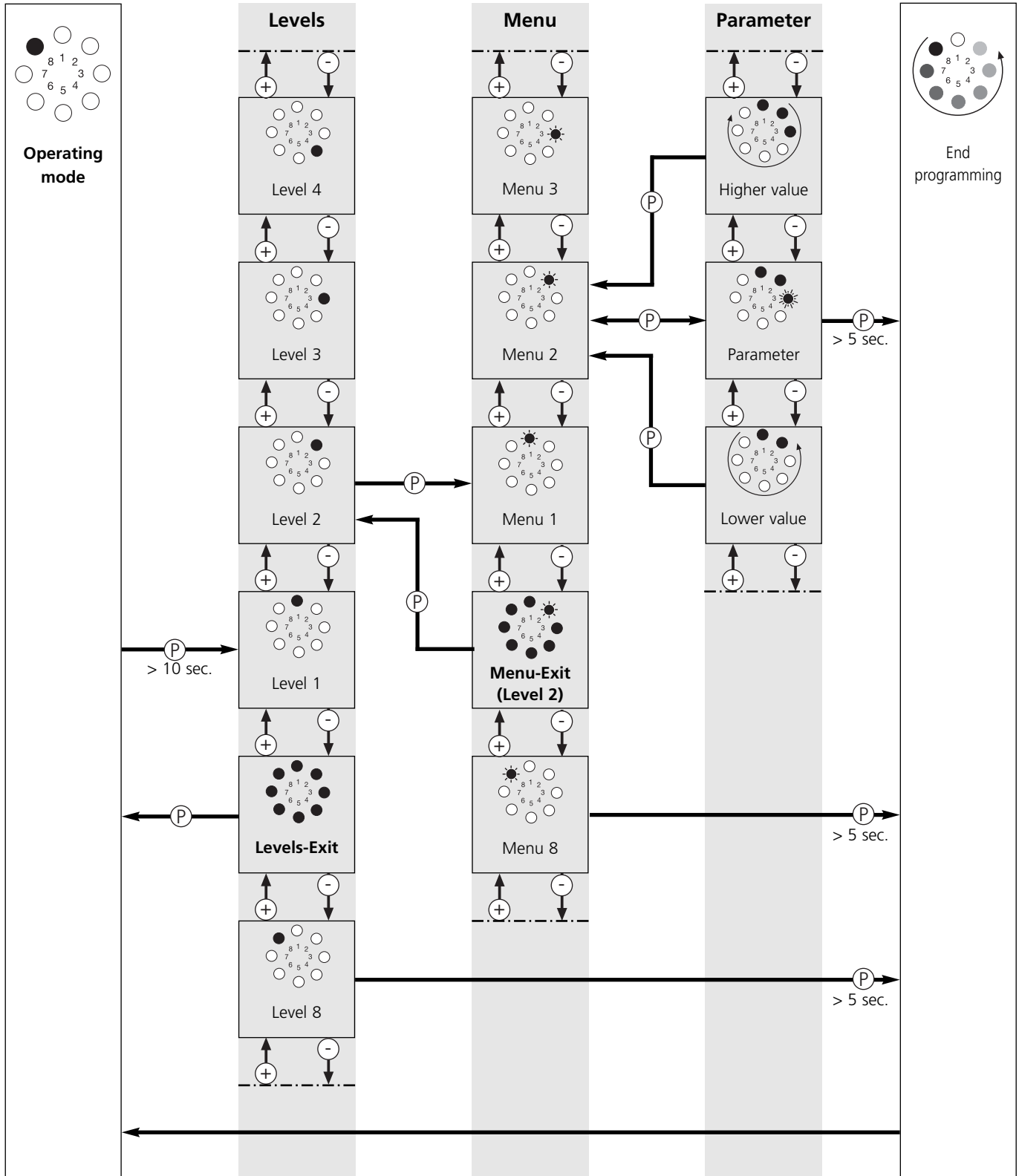

## 9. Extended operator functions

### 9.2 General overview of the programmable functions

Level	Menu	Factory default setting
<b>Level 1 – Basic functions</b>	Menu 3: Intermediate position OPEN	–
	Menu 4: Intermediate position CLOSE	–
	Menu 7: Relay output	Signal light
	Menu 8: RESET	No reset
<b>Level 2 – Operator settings</b>	Menu 1: Required driving power OPEN	Setting 8
	Menu 2: Required driving power CLOSE	Setting 8
	Menu 3: Automatic cut-out OPEN	Setting 8
	Menu 4: Automatic cut-out CLOSE	Setting 8
<b>Level 3 – Automatic closing timer</b>	Menu 1: Automatic closing timer	Deactivated
	Menu 3: Door open duration	2 Seconds
	Menu 4: Warning time	1 Seconds
	Menu 5: Start-up warning	0 Seconds
	Menu 7: Signal light	Door movement / Warning: flashing Door stoppage: off
<b>Level 4 – Remote programming</b>	Menu 2: Intermediate position	–
<b>Level 5 – Special function</b>	Menu 1: Programmable impulse input	Impulse
	Menu 4: Lighting duration	180 Seconds

## 9. Extended operator functions

Level	Menu	Factory default setting
<b>Level 6 - Variable speed</b>	Menu 1: Speed OPEN	Setting 16
	Menu 2: Soft run speed OPEN	Setting 6: Comfort 220.2 Setting 7: Comfort 250.2 Comfort 252.2 Comfort 250.2 speed
	Menu 3: Soft run position OPEN	–
	Menu 4: Speed CLOSE	Setting 10: Comfort 250.2 speed Setting 16: Comfort 220.2 Comfort 250.2 Comfort 252.2
	Menu 5: Smart run speed, CLOSE	Setting 10
	Menu 6: Soft run speed CLOSE	Setting 6: Comfort 220.2 Setting 7: Comfort 250.2 Comfort 252.2 Comfort 250.2 speed
	Menu 7: Smart run position, CLOSE	–
	Menu 8: Soft run position CLOSED	–
<b>Level 8 – System settings</b>	Menu 1: Photocell	Operation without photocell
	Menu 3: Function of the automatic cut-out	Door stops (OPEN) Door reverses a little (CLOSE)
	Menu 4: Operating modes	Press-and-release (OPEN/CLOSE)
	Menu 5: Function of the direction command transmitters	Not active
	Menu 6: Function of the impulse command transmitters	STOP only, then standard sequence

## 9. Extended operator functions

### 9.3 Functions overview for the levels



#### Caution!

Important factory default settings can be changed using the extended functions. All the parameters must be set correctly to avoid damage to persons or property.

Level 1 – Basic functions																
	1	2	3	4	5	6	7	8	9	10	11	12	13	14	15	16
<b>Menu 3: Intermediate position OPEN</b>																
	Set using the (+ / OPEN) and (- / CLOSE) buttons “Intermediate position OPEN” – closing function is possible with automatic closing timer															
<b>Menu 4: Intermediate position CLOSE</b>																
	Set using the (+ / OPEN) and (- / CLOSE) buttons															
<b>Menu 7: Relay output (only programmable with optimum signal light relay)</b>																
	A7	B7	C7	D7	E7	F7	G7	H7	I7	J7	K7	-	-	-	-	-
<b>Menu 8: RESET</b>																
	A8	B8	C8	D8	E8	F8	-	-	-	-	-	-	-	-	-	-



#### Attention!

After a reset, all the parameters revert to the factory settings.

In order to ensure that the controls operate properly:

- all the required functions must be re-programmed,
- the remote control unit must be re-programmed,
- the drive system must be driven once to the OPEN and CLOSED door positions.



#### Advice:

- Only the intermediate position that was programmed last can be used.
- If an automatic closing timer is activated (Level 3 / Menu 1), the relay output (Level 1 / Menu 7) cannot be programmed.

## 9. Extended operator functions



### Reference:

If changes are made in Menus 3 and 4 in Level 1, a new performance check must be carried out (Section 8.5).

### Menu 7: Relay output

Setting	Function (with optional signal light relay only)	Explanation / Advice	
A7	Signal light	Function	Level 3 Menu 7
B7	Door position: OPEN	-	-
C7	Door position: CLOSED	-	-
D7	Intermediate position OPEN	-	-
E7	Intermediate position CLOSED	-	-
F7	Drive system starts running	Wiping impulse 1 second	-
G7	Problem	-	-
H7	Lighting	Lighting duration	Level 5 / Menu 4
I7	Automatic locking release	Drive system is running	-
J7	Lock release	Drive system starts running / Wiping impulse 3 seconds	-
K7	Push-open security device	-	-

### Menu 8: Reset

Setting	Function	Explanation / Advice	
A8	No reset	unchanged	-
B8	Reset control unit *	Factory default setting	-
C8	Reset remote control	Messages are deleted	-
D8	Reset extension, automatic closing timer	level 3, menu 1-7	-
E8	Reset extended operator functions only *	except door OPEN/CLOSED positions and remote control impulse	-
F8	Reset safety devices *	Photocell	-

\* All connected and operational safety devices are recognised automatically after resetting.



## 9. Extended operator functions

Level 2 – Operator settings																
	1	2	3	4	5	6	7	8	9	10	11	12	13	14	15	16
<b>Menu 1: Required driving power OPEN (sensitivity in increments*)</b>																
	1	2	3	4	5	6	7	8	9	10	11	12	13	14	15	16
<b>Menu 2: Required driving power CLOSE (sensitivity in increments*)</b>																
	1	2	3	4	5	6	7	8	9	10	11	12	13	14	15	16
<b>Menu 3: Automatic cut-out OPEN (sensitivity in increments**)</b>																
	OFF	2	3	4	5	6	7	8	9	10	11	12	13	14	15	16
<b>Menu 4: Automatic cut-out CLOSE (sensitivity in increments**)</b>																
	OFF	2	3	4	5	6	7	8	9	10	11	12	13	14	15	16

\* The higher the setting, the higher the driving power.

\*\* The lower the setting, the more sensitive the automatic cut-out.



### Caution!

To exclude any risk of injury, the automatic cut-out (Menus 3 and 4) may only be switched to OFF if a photocell barrier or closing edge safety device is installed.

Legend:	
LED off	○
LED on	●
LED flashes slowly	☀
LED pulses	⚡
LED flashes quickly	☀
Factory default setting	
Not possible	–

## 9. Extended operator functions

Level 3 - Automatic closing timer																
	1	2	3	4	5	6	7	8	9	10	11	12	13	14	15	16
Menu 1: Automatic closing timer																
	A1	B1	C1	D1	E1	F1	G1	H1	-	-	-	-	-	-	-	-
Menu 3: Door open duration (in seconds)																
	2	5	10	15	20	25	30	35	40	50	80	100	120	150	180	255
Menu 4: Warning time (in seconds)																
	1	2	5	10	15	20	25	30	35	40	45	50	55	60	65	70
Menu 5: Start-up warning (in seconds)																
	0	1	2	3	4	5	6	7	-	-	-	-	-	-	-	-
Menu 7: Signal light																
	A7	B7	C7	D7	E7	F7	-	-	-	-	-	-	-	-	-	-



### Advice:

- The automatic closing timer can only be programmed if a photocell barrier is connected.
- The functions in Menu 1 can be altered as desired via the time settings in Menus 3 and 4.

Legend:	
LED off	○
LED on	●
LED flashes slowly	☀
LED pulses	⚙
LED flashes quickly	☀
Factory default setting	
Not possible	-

## 9. Extended operator functions

### Menu 1: Automatic closing timer

Setting	Door open duration	Warning time	Automatic closing timer	Other functions
A1	-	-	deactivated	-
B1	15	5	activated	Extension of door OPEN time only through impulse signal (button, hand transmitter)
C1	30	5	activated	
D1	60	8	activated	
E1	15	5	activated	Interruption of the door open duration after the photocell barrier has been driven past
F1	30	5	activated	
G1	60	8	activated	
H1	unlimited	3	activated	Closes after the photocell barrier has been driven past / closing prevention



#### Advice:

Without a connected photocell or closing prevention device, only parameter A1 can be adjusted.

### Menu 7: Signal light



Setting	Door movement / Warning	Door stoppage
<b>A7</b>	flashing	OFF (Electricity saving)
<b>B7</b>	lighting	OFF (Electricity saving)
<b>C7</b>	flashing	flashing
<b>D7</b>	lighting	lighting
<b>E7</b>	flashing	lighting
<b>F7</b>	lighting	flashing





















#### Reference:

The signal light connection can be adjusted in level 1, menu 7.

## 9. Extended operator functions

Level 4 – Remote programming	
	
Menu 2: Intermediate position	
	LED 7 flashes slowly -> press the hand transmitter button -> LED 7 flashes quickly

Level 5 – Special function																
	1	2	3	4	5	6	7	8	9	10	11	12	13	14	15	16
																
Menu 1: Programmable impulse input - Terminal 1/2																
	A1	B1	C1	D1	E1	-	-	-	-	-	-	-	-	-	-	-
Menu 4: Lighting duration (in seconds)																
	2	5	10	15	20	25	30	35	40	50	80	100	120	150	180	255

### Menu 1: Programmable impulse input

Setting	Function (with optional signal light relay only)	Explanation / Advice
A1	Impulse	normally open contact only
B1	Automatic on/off	normally open contact only
C1	closing prevention device	only in CLOSE direction – normally closed contact only
D1	Impulse OPEN	induction loop - normally open contact only
E1	Stop	normally closed contact only



#### Reference:

- The programming of the special function is dependent on terminal XB01. Terminal XB01 is described in Section 6.6.
- The lighting duration programmed is only active when the relay output (Level 1 / Menu 7) is programmed for lighting (H7).

## 9. Extended operator functions

Level 6 - Variable speed																
	1	2	3	4	5	6	7	8	9	10	11	12	13	14	15	16
<b>Menu 1: Speed OPEN (in increments)</b>																
	-	-	-	-	-	-	7	8	9	10	11	12	13	14	15	16
<b>Menu 2: Soft run speed OPEN (in increments)</b>																
	1	2	3	4	5	6 (A)	7 (B, C, D)	8	9	10	11	12	13	14	15	16
<b>Menu 3: Soft run position OPEN</b>																
	Set using the (+ / OPEN) and (- / CLOSE) buttons															
<b>Menu 4: Speed CLOSE (in increments)</b>																
	-	-	-	-	-	-	7	8	9	10 (D)	11	12	13	14	15	16 (A, B, C)
<b>Menu 5: Smart run speed, CLOSE (in increments)</b>																
	1	2	3	4	5	6	7	8	9	10	11	12	13	14	15	16
<b>Menu 6: Soft run speed CLOSE (in increments)</b>																
	1	2	3	4	5	6 (A)	7 (B, C, D)	8	9	10	11	12	13	14	15	16
<b>Menu 7: Smart run position, CLOSE</b>																
	Set using the (+ / OPEN) and (- / CLOSE) buttons															
<b>Menu 8: Soft run position CLOSED</b>																
	Set using the (+ / OPEN) and (- / CLOSE) buttons															

- A Comfort 220.2
- B Comfort 250.2
- C Comfort 252.2
- D Comfort 250.2 speed



### Reference:

If changes are made in Menus 1, 2, 3, 4, 6 and 8 in Level 6, a new performance check must be carried out (Section 8.5).

## 9. Extended operator functions

Level 8 – System settings																
	1	2	3	4	5	6	7	8	9	10	11	12	13	14	15	16
<b>Menu 1: Photocell</b>																
	A1	B1	C1	D1	-	-	-	-	-	-	-	-	-	-	-	-
<b>Menu 3: Function of automatic cut-out</b>																
	A3	B3	C3	D3	-	-	-	-	-	-	-	-	-	-	-	-
<b>Menu 4: Operating modes</b>																
	A4	B4	C4	D4	-	-	-	-	-	-	-	-	-	-	-	-
<b>Menu 5: Function of the direction command transmitters</b>																
	A5	B5	-	-	-	-	-	-	-	-	-	-	-	-	-	-
<b>Menu 6: Function of the impulse command transmitters</b>																
	A6	B6	-	-	-	-	-	-	-	-	-	-	-	-	-	-



### Attention!

If a photocell is connected, it is automatically recognised by the controls after MAINS ON.  
The photocell can be reprogrammed later.

Legend:	
LED off	○
LED on	●
LED flashes slowly	☀
LED pulses	☀ •
LED flashes quickly	☀ ••
Factory default setting	
Not possible	-

## 9. Extended operator functions

---

### Menu 1: Photocell

Setting	Photocell 1 (Connection XP020) Door movement, CLOSE	Photocell 2 (Connection XB01 - Terminal 70/71) Door movement, CLOSE
A1	Operation without photocell	
B1	Door reverses completely <sup>2</sup>	not active
C1	not active	Door reverses completely <sup>2</sup>
D1	Door reverses completely <sup>2</sup>	Door reverses completely <sup>2</sup>

### Menu 3: Function of automatic cut-out

Setting	Door movement, OPEN	Door movement, CLOSE
A3	Door stops	Door reverses a little <sup>1</sup>
B3	Door reverses a little <sup>1</sup>	Door reverses a little <sup>1</sup>
C3	Door stops	Door reverses completely <sup>2</sup>
D3	Door reverses completely <sup>2</sup>	Door reverses completely <sup>2</sup>

### Menu 4: Operating modes

Setting	OPEN	CLOSE
A4	press and hold	press and hold
B4	automatic closing	press and hold
C4	press and hold	automatic closing
D4	automatic closing	automatic closing

<sup>1</sup> Door reverses a little: The drive system moves the door a short distance in the opposite direction in order to free an obstacle.

<sup>2</sup> Door reverses completely: The drive system moves the door to the opposite end position.



## 9. Extended operator functions

---

### Menu 5: Function of the direction command transmitter

Setting	Direction command transmitters	Explanations
<b>A5</b>	not active	The direction command transmitters only give a command when the door is stationary.
<b>B5</b>	STOP only	A moving door is stopped by every direction command transmitter.

### Menu 6: Function of the impulse command transmitter

Setting	Impulse command transmitters	Explanations
<b>A6</b>	not active	The impulse command transmitters only give a command when the door is stationary.
<b>B6</b>	STOP only, then standard sequence	A moving door is stopped by every impulse command transmitter. The next command starts the drive system running in the opposite direction (OPEN - STOP - CLOSE - STOP - OPEN).

# 10. Messages

## 10.1 Malfunctions without error messages

Error	Cause	Solution
LED 8 does not light up.	- No voltage.	- Check that the mains power supply is operational. - Check the connection to the mains power supply.
	- Thermal overload protection in power transformer was activated.	- Allow the power transformer to cool down.
	- Defective control unit.	- Have the operator system checked.
No reaction on impulse.	- The connection terminals for the "impulse" button were by-passed, e.g. due to a short-circuit or flattened terminals.	- Try temporarily disconnecting any key switches or interior push buttons that are connected to the control unit (Section 6.6): remove the cable from socket XB10, insert the shorting plug and look for cabling errors.
No reaction on impulse from hand transmitter.	- Module antenna is not plugged in.	- Connect the module antenna to the control unit (Section 8.1).
	- The hand transmitter coding does not correspond to the receiver coding.	- Activate hand transmitter again (Section 8.4).
	- Hand transmitter battery is empty.	- Insert new battery (Section 7.1).
	- Defective hand transmitter, control unit electronics or module antenna.	- Have all 3 components checked.
Operator reverses when the door frame photocell is interrupted.	- Programming was not carried out correctly.	- Carry out a reset of the safety devices (Section 9.4, / Level 1 / Menu F8), carry out express programming again (Section 8.4).

Legend:	
LED off	○
LED on	●
LED flashes slowly	☼
LED pulses	⚙
LED flashes quickly	☼
Factory default setting	
Not possible	-

## 10. Messages

### 10.2 Malfunctions with error messages

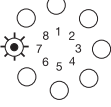
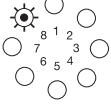
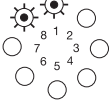
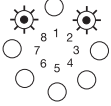
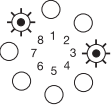
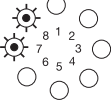
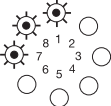
Error	Cause	Solution
Message 7 	<ul style="list-style-type: none"> <li>- If no buttons are pressed within 120 seconds, the programming mode terminates automatically.</li> <li>- OPEN and CLOSED door positions programmed without passing the reference point.</li> </ul>	
Message 8 	<ul style="list-style-type: none"> <li>- Reference point button defective.</li> </ul>	<ul style="list-style-type: none"> <li>- Have the operator system checked.</li> </ul>
Message 9 	<ul style="list-style-type: none"> <li>- No speed sensor impulses, drive system is blocked.</li> </ul>	<ul style="list-style-type: none"> <li>- Have the operator system checked.</li> </ul>
Message 10 	<ul style="list-style-type: none"> <li>- Door movement too stiff.</li> <li>- Door blocked.</li> </ul>	<ul style="list-style-type: none"> <li>- Ensure that the door moves easily.</li> </ul>
	<ul style="list-style-type: none"> <li>- Maximum driving power setting is too low.</li> </ul>	<ul style="list-style-type: none"> <li>- Have the max. driving power (Section 9.3 / Level 2 / Menu 1+2) checked by an expert.</li> </ul>
Message 11 	<ul style="list-style-type: none"> <li>- Excess travel stop.</li> </ul>	<ul style="list-style-type: none"> <li>- Have the operator system checked.</li> </ul>
Message 15 	<ul style="list-style-type: none"> <li>- External photocell interrupted or defective.</li> </ul>	<ul style="list-style-type: none"> <li>- Remove obstacle or have the photocell checked.</li> </ul>
	<ul style="list-style-type: none"> <li>- Programmed for photocell, but no photocell is connected.</li> </ul>	<ul style="list-style-type: none"> <li>- Deactivate or connect the photocell.</li> </ul>
Message 16 	<ul style="list-style-type: none"> <li>- Power sensor for the automatic cut-out is defective.</li> </ul>	<ul style="list-style-type: none"> <li>- Have the motor unit checked.</li> </ul>

## 10. Messages

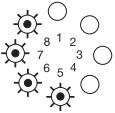
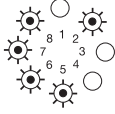
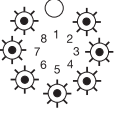
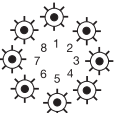
Error	Cause	Solution
Message 26 	- Undervoltage, operator system overloaded at maximum power setting, 16.	- Have the external power supply checked. - Ensure that the door moves easily.
Message 28 	- Door movement too stiff or irregular. - Door blocked.	- Check the path of the door and ensure that the door moves easily.
	- Automatic cut-out is set to be too sensitive.	- Have the automatic cut-out facility checked by an expert (Section 9.3 / Level 2 / Menu 3+4).
Message 35 	- Electronics are defective.	- Have the operator system checked.
Message 36 	- Shorting plug removed, although a stop button is not connected. - Closed circuit is interrupted.	- Connect stop button or insert shorting plug (Section 6.6).

Legend:	
LED off	○
LED on	●
LED flashes slowly	⊙
LED pulses	⊙
LED flashes quickly	⊙
Factory default setting	
Not possible	-

# 11. Attachment

## 11.1 Technical Data for Comfort 220.2, 250.2, 252.2, 250.2 speed

Electrical data		Comfort 220.2	Comfort 250.2	Comfort 252.2	Comfort 250.2 speed
Nominal voltage *)	V	230 / 260			
Nominal frequency	Hz	50 / 60			
Power consumption	A	1.1			
Power input - operation	KW	0.25			
Power input - stand-by	W	4.2	3.0	3.1	4.0
Operating mode (operating time)	Min.	KB 2		KB 5	KB 2
Control voltage	V DC	24			
Protection category, motor unit		IP 20			
Protection class		II			
*) subject to country-specific alternations					

Mechanical data		Comfort 220.2	Comfort 250.2	Comfort 252.2	Comfort 250.2 speed
Max. push and pull force	N	600	800	1,000	800
Travel speed	mm/sec.	140			220
Opening time (door specific)	sec.	15			9.5

General data		Comfort 220.2	Comfort 250.2	Comfort 252.2	Comfort 250.2 speed
Motor unit dimensions	mm	220x125x395			
Weight	kg	3.8	4.1	4.2	4.5
Temperature range	°C	-20 to +60			

Supply package *)	
Motor unit	
Comfort 220.2, 250.2, 252.2, 250.2 speed with integrated electronic controls	
Multibit remote control, 868 MHz, Digital 302 mini hand transmitter, 2-channel,	
Multibit remote control, 868 MHz, Digital 313 micro hand transmitter, 3-channel	
*) subject to country-specific alternations	

Features / Safety functions	
Reference point technology	x
Soft-Start / Soft-Stop	x
Delay safety device	x
Automatic cut-out	x
Blocking protection	x
Undervoltage protection	x
Excess travel stop	x
Electronic travel cut-out	x
Connection for pushbuttons, code buttons and key switches	x
Connection of potential-free limit switch message system	x
Error messages	x

Accessories	
Modular antenna, 868 MHz, IP 65	x
Mounting supports for sectional doors	x
Release kits for swinging doors	x
Adapter arm for retractable up-and-over doors	x
Fittings for winged doors	x
Photocells	x
Emergency release	x
Relay for flashing signal light when the automatic closing timer is operational	x
Retrofit kit for potential-free limit switches OPEN/CLOSE/LIGHT	x
Push button	x
Key switch	x
Code switch	x



## 11. Attachment

### 11.2 Manufacturer's Declaration

We hereby declare that the product sold by us and mentioned below corresponds in its design, construction and version to the relevant and basic health and safety requirements of the following EC regulations: EMC Directive, Machinery Directive and Low Voltage Directive.

Product changes made without our consent will render this Declaration void.

**Product: Comfort 220.2, 250.2, 252.2, 250.2 speed**

Relevant EC Regulations:

- EC EMC Directive (89/336/EWG),
- Machinery Directive (98/37/EWG) and
- Low Voltage Directive (73/23/EWG und 93/68/EWG).

Applied harmonised standards, in particular:

EN 292-1  
EN 61000-6-2  
EN 61000-6-3  
EN 55014  
EN 61000-3-2  
EN 61000-3-3  
EN 60335-1  
EN 60335-2-95  
EN 12445  
EN 12453  
EN 300220-1  
EN 301489-3  
ETS 300683

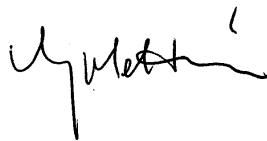

02.01.2008

ppa. K. Goldstein

### 11.3 EC Declaration of Conformity

We hereby declare that the product sold by us and mentioned below corresponds in its design, construction and version to the relevant and basic health and safety requirements of the following EC regulations: EMC Directive, Machinery Directive and Low Voltage Directive.

Product changes made without our consent will render this Declaration void.

**Product:**

Relevant EC Regulations:

- EC EMC Directive (89/336/EWG),
- Machinery Directive (98/37/EWG) and
- Low Voltage Directive (73/23/EWG und 93/68/EWG).

Applied harmonised standards, in particular:

EN 292-1  
EN 61000-6-2  
EN 61000-6-3  
EN 55014  
EN 61000-3-2  
EN 61000-3-3  
EN 60335-1  
EN 60335-2-95  
EN 12445  
EN 12453  
EN 300220-1  
EN 301489-3  
ETS 300683

Date / Signature

**English**

Copyright.

No part of this manual may be reproduced without our prior consent.  
Subject to changes which are in the interest of technical improvements.



\*83988\*

Valid from: 04.2009  
#83 988

1 - GB 360283 - M - 0.5 - 0308