



designed to *glide*™

# Storm • Safe™

Home Protection Garage Doors



---

**C2 Rated Roller Garage Door  
Installation & User Guide**

# **IMPORTANT - SAFETY INFORMATION**

**WARNING: UNIT MUST BE INSTALLED AS OUTLINED AND IN STRICT ACCORDANCE WITH THE FOLLOWING INSTRUCTIONS. FAILURE TO COMPLY WITH THE FOLLOWING INSTRUCTIONS AND SAFETY WARNINGS MAY RESULT IN SERIOUS PERSONAL INJURY AND/OR PROPERTY DAMAGE.**

**NO GUARANTEE WILL BE GIVEN OR RESPONSIBILITY ACCEPTED BY THE MANUFACTURER IF THE DOOR IS NOT INSTALLED BY AN AUTHORISED GLIDEROL INSTALLER.**

## **Contents**

<b>1.0</b>	<b>Preparing for Installation</b>	<b>3</b>
1.1	Door Clearances and Dimensions	3
2.0	Affixing Mounting Brackets	4
<b>3.0</b>	<b>Positioning the Door</b>	<b>5</b>
<b>4.0</b>	<b>Unrolling the Door</b>	<b>5</b>
<b>5.0</b>	<b>Assembling the Guide Tracks</b>	<b>6</b>
<b>6.0</b>	<b>Fixing the Guide Tracks</b>	<b>7</b>
<b>7.0</b>	<b>Stop Block Installation</b>	<b>8</b>
<b>8.0</b>	<b>Final Adjustments</b>	<b>8</b>
<b>9.0</b>	<b>Fitting Locking Bar</b>	<b>9</b>
<b>10.0</b>	<b>Reference Tables</b>	<b>10</b>
<b>11.0</b>	<b>Installation Faults and Remedies</b>	<b>11</b>
<b>12.0</b>	<b>Maintenance</b>	<b>12</b>
<b>13.0</b>	<b>Appendix</b>	<b>13</b>
<b>4.0</b>	<b>Warranty</b>	<b>14</b>

# 1.0 Preparing for Installation

Remove all parts from their packaging - **THE WRAPPING HOLDING THE DOOR MUST NOT BE CUT AT THIS STAGE.**

The doors are positioned inside the opening. To provide adequate curtain coverage, overlap the opening on each side by 60mm for series A/AA and B series doors. A minimum of side room of 150mm is required between the opening and the side wall for A & AA Series doors being manually operated and 150mm for automatically operated doors. B Series Industrial doors require a minimum side room of 250mm for both manual and automatic door operation.

Before commencing, measure both the opening and the door curtain and mark the overlap on the wall to facilitate the fixing of brackets and guides.

## 1.1 Door Clearances and Dimensions

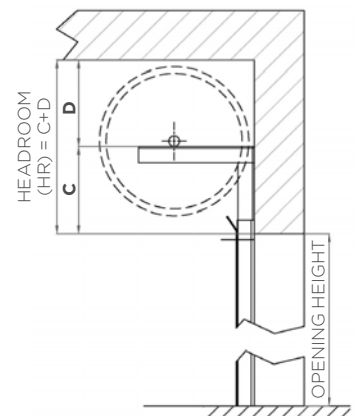
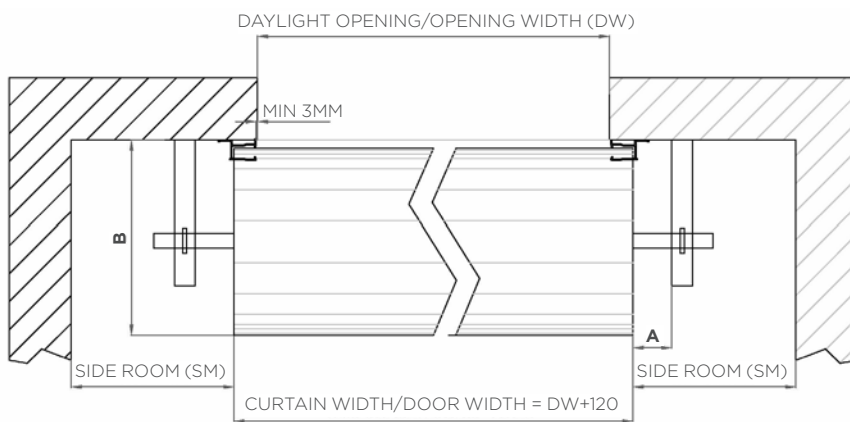

### Series 'A' and 'AA' C2 Windlock Roller Doors

Minimum Dimensions

Opening Height (mm)	Side Room SR			Head Room (HR)	A	B	C	D
	Manual	Auto - Limited SR	Auto - Standard SR					
2100	150	150	200	430	50	500	170	260
2400	150	150	200	470	50	540	190	280
2700	150	150	200	470	50	540	190	280
3000	150	150	200	510	50	560	210	300

### Series 'B' Industrial C2 Windlock Roller Doors

Minimum Dimensions

Opening Height (mm)	Side Room SR (Manual & Auto)	Head Room (HR)	A	B	C	D
Up to 3000	250	510	75	560	210	300
Up to 5000	250	550	75	580	230	320

### Maximum Door Width for C1 & C2 Wind Classification

Wind Classification	Ultimate Design Wind Pressure (kPa)		Max Door Width	Max Force Fx	Max Force Fy
	Inward	Outward			
C1 & C2	2.92	-3.37	3430mm	22.23 kN/m	5.36 kN/m

## 2.0 Affixing Mounting Brackets

### A & AA Series (Residential Door Setup)

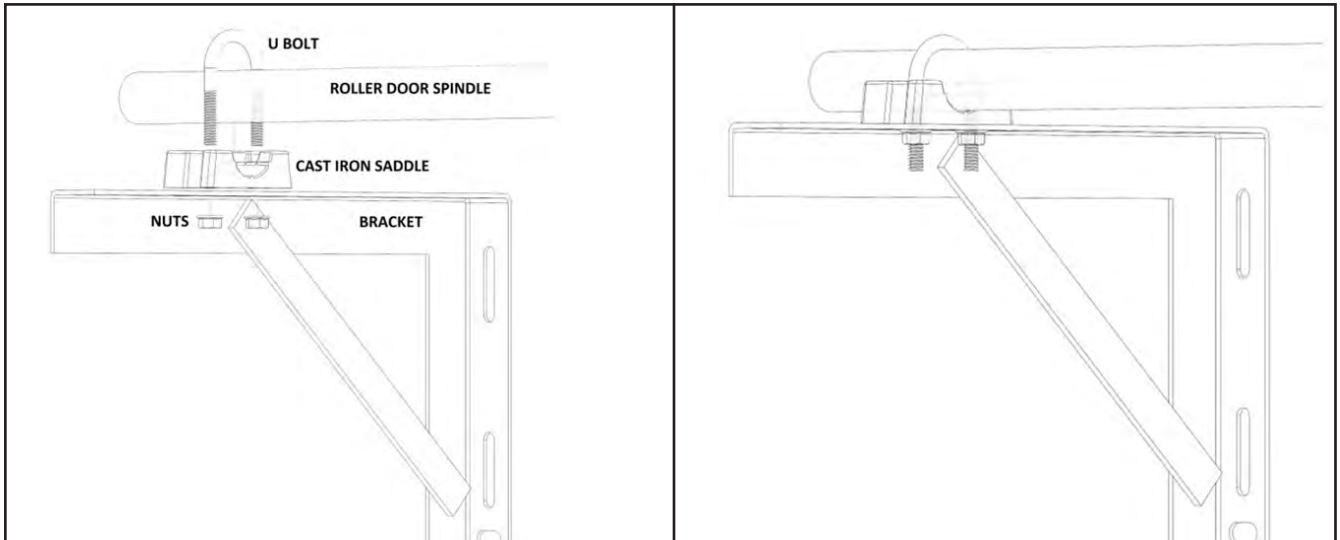

### B Series (Light Industrial Door Setup)

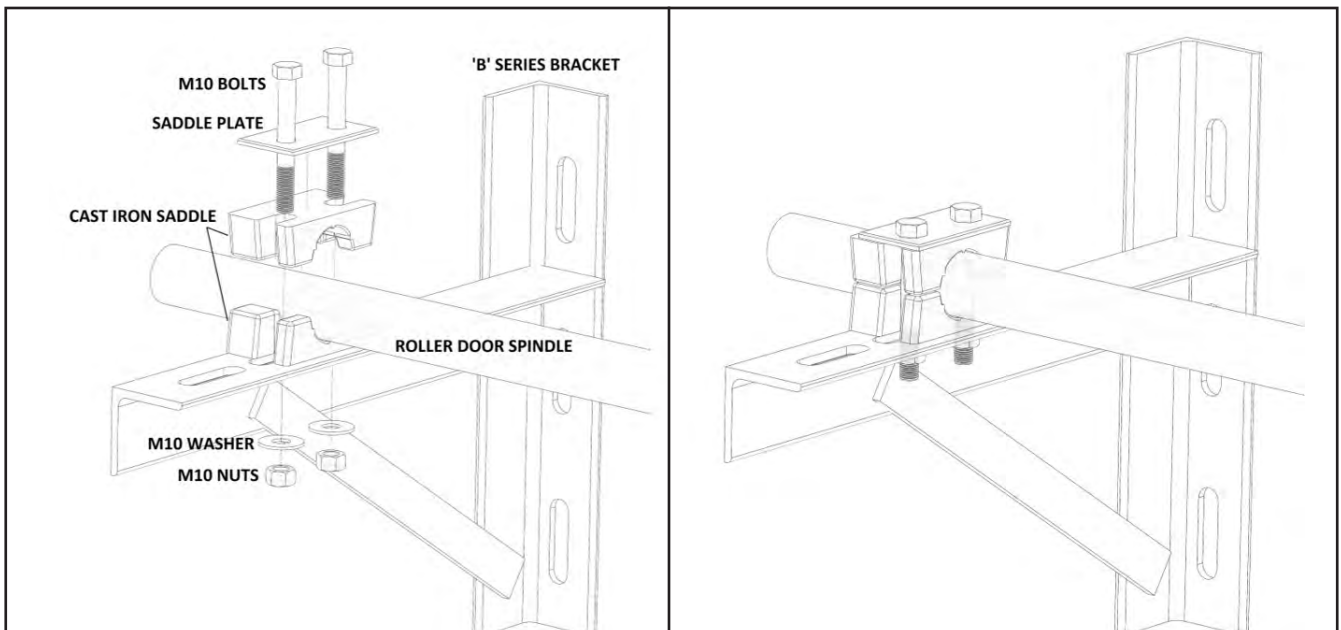

Refer previous page for minimum headroom required between the underside of the rafters and the top of the opening for type of door being installed (A/AA/B series Doors).

Firmly secure one of the mounting brackets with appropriate fixings for the material you are fixing to (refer reference tables for maximum pull out strength requirements when selecting fixings). It is important that the outside face (flat smooth side) of the angle brackets faces the side wall of the garage.

The minimum clearance on either side between the door curtain and mounting brackets is 50mm for A/AA Doors and 75mm for B series Doors. (Manual Doors Only). Referring to the Door Clearances and Dimensions on previous page, position the first bracket depending on door type (A/AA or B series).

The second mounting bracket should then be positioned. The use of a line level or spirit level and straight edge is recommended as **IT IS VITAL THAT THE BRACKETS ARE EXACTLY LEVEL WITH EACH OTHER**, otherwise the door will not sit square.

## 3.0 Positioning the Door

First make sure the axle is centered within the curtain roll. Place the rolled up door on the mounting brackets and centre the axle approximately 250mm from the front wall, ensuring that the door is centralized with the opening.

Please Note: If the side clearance for the axle is insufficient, cut **EACH END** of the axle. **IT IS IMPORTANT THAT THE AXLE IS NOT CUT TOO SHORT.**

Ensure that the door is placed in the correct way round on the brackets. The below image illustrates the relative position of the bottom rail.

Secure the axle to the mounting brackets with the U Bolts. **LOCK TIGHTLY** using washers under the nuts. Spring tension will be lost if the axle is not firmly clamped. Tension should now be applied to the spring by rotating the door about 1 1/2 times in a forward direction, as shown. The amount of tension required to give the best operation may vary with individual doors. Final adjustment should be made on completion of installation.

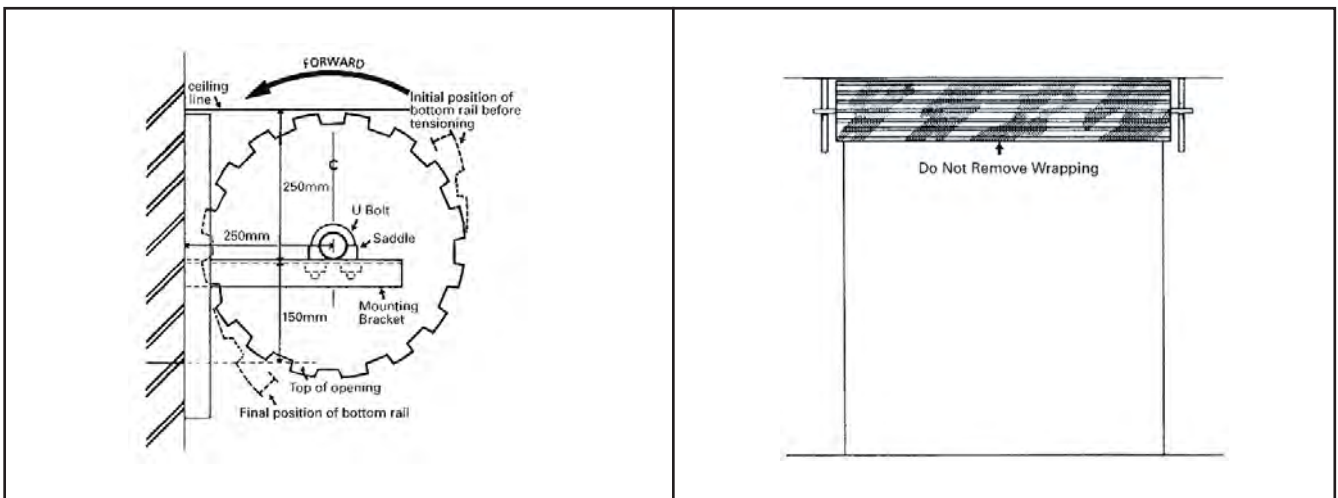

## 4.0 Unrolling the Door

Hold the door in its tensioned position and remove the wrapping which holds the door in a roll. It is important that the door is held firmly at this stage to prevent loss of tension. Pull the door partly down.

**THE DOOR MAY HAVE A STRONG TENDENCY TO RISE WHICH, IF UNCONTROLLED, CAN CAUSE DAMAGE.**

Use a piece of soft timber as a chock, approx 450mm long, and place it between the bottom rail and the drum, as shown, taking care not to damage the door.

Please Note: When lifting the Polyglide, ensure that the PVC finned weatherseal remains in position.

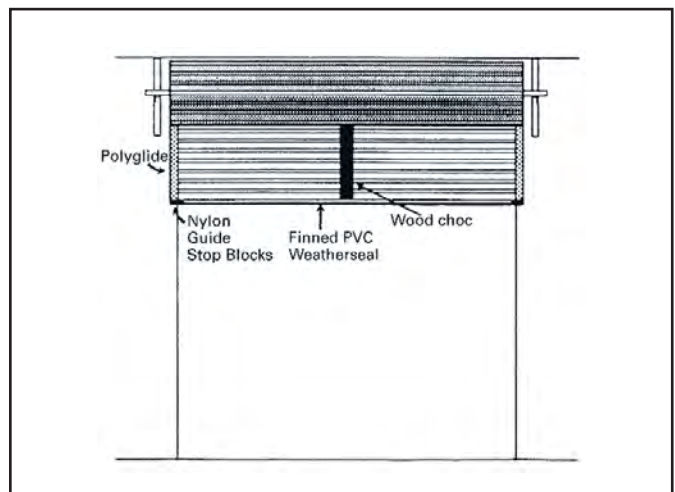

# 5.0 Assembling the Guide Tracks

## 2.1 Standard Guide Tracks Assembly

Insert the Nylon Infeed into the aluminium guide (sliding from the top of the guide) ensuring it aligns and sits tightly as shown in the image below.

Slide the metal Stop Bar horizontally into the Nylon Infeed and align with the hole. Insert the M8 countersunk screw from the back of the guide passing through the guide countersunk hole, Nylon Infeed and metal Stop Bar.

Using M8 washer and M8 Nyloc nut secure the whole assembly.

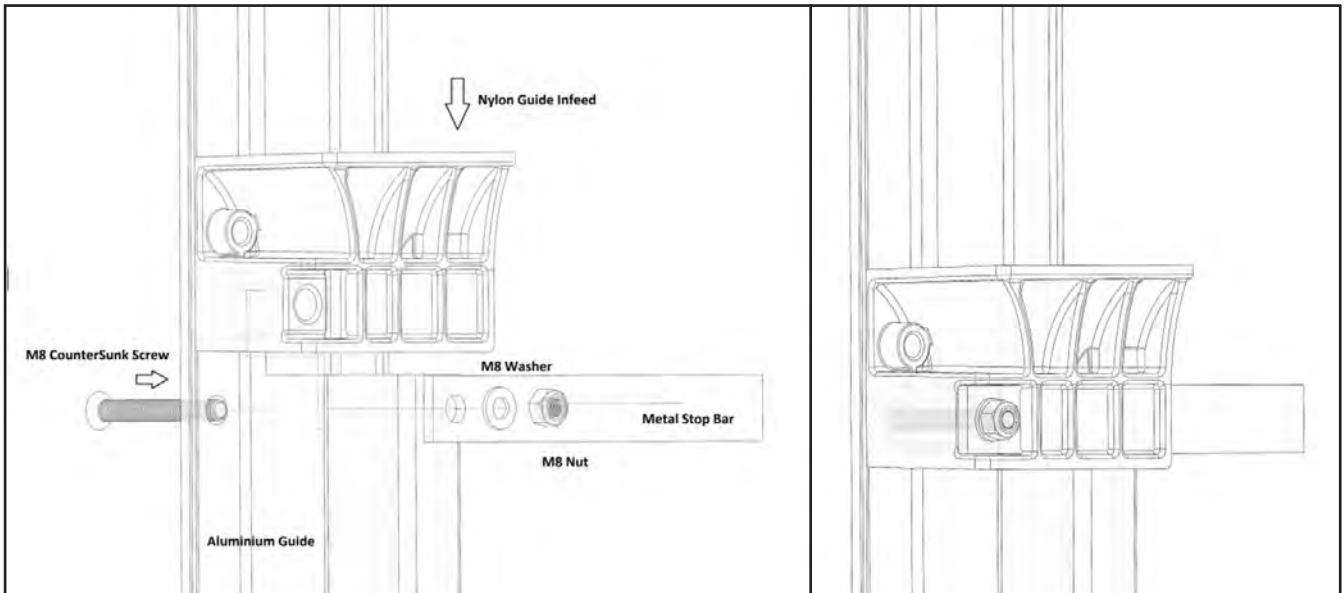

## 2.1 Alternate Guide Tracks Assembly (Steel-Fix Only)

Nylon Infeed and Stop Bar assembly can also be installed after the Guides have been installed when fixing to steel abutment.

Insert the Nylon Infeed into the aluminium guide (sliding from the top of the guide) ensuring it aligns and sits tightly as shown in the image below. Slide the metal Stop Bar horizontally in to the Nylon Infeed and align with the hole.

Using 14-10 x 95mm long Self drilling screw and m8 washer secure the whole assembly as shown below.

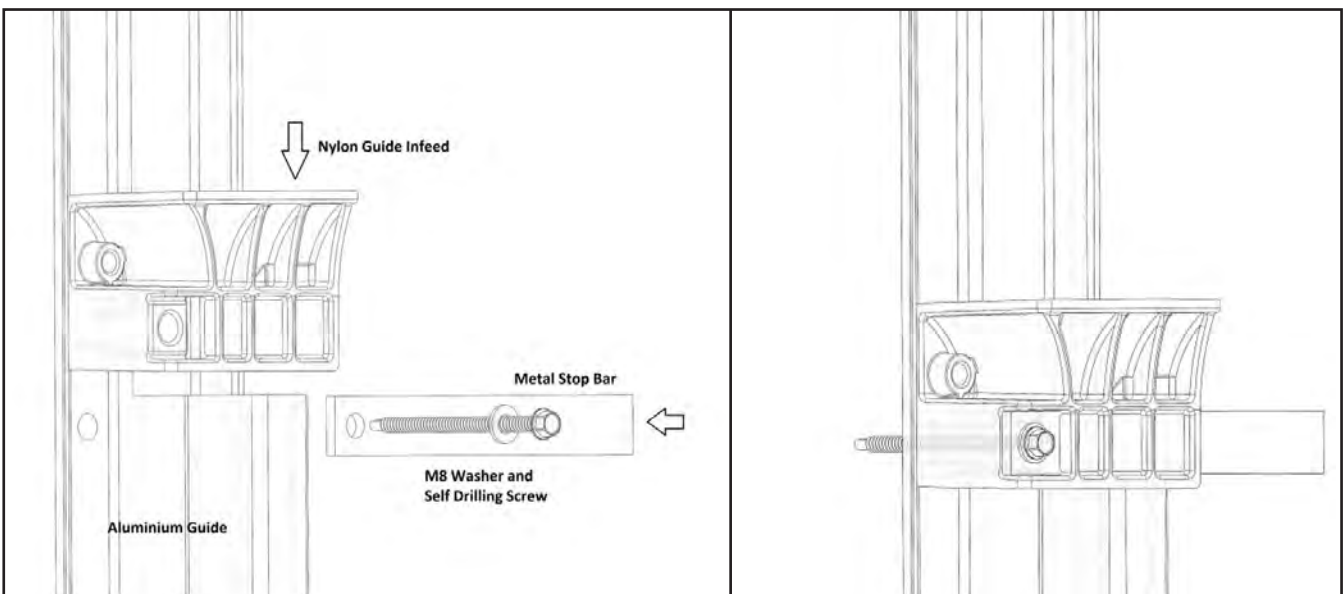

## 6.0 Fixing the Guide Tracks

Carefully remove the wood chock, if used. Ensure that the door curtain is rolled up evenly and centered on the opening.

Should the door be coned due to movement in transit, then the door curtain should be carefully unrolled to its full extent and rolled back evenly before continuing, making sure the curtain is no longer in a coned position.

The bottom of the side tracks must be at finished floor line. If the floor is slightly out of level, always work from the higher side first. The top of the tracks (splayed end) should be level with the top of the bearing surface of the mounting brackets for doors up to 3000mm high and for doors higher than 3000mm high the brackets should be lowered by 100mm as shown in figure below.

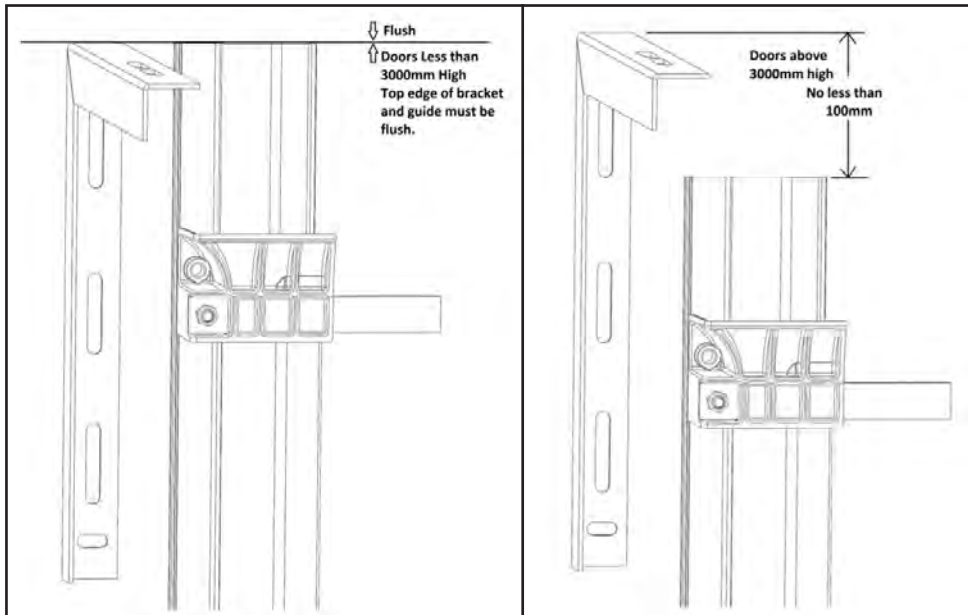

Cut one side track to the correct length if necessary, at the bottom.

Slide the track on to the door curtain, allowing 4mm clearance. Maintain a minimum of 3mm gap from the edge of the opening to the guide as shown in the image, also refer to appendix 1.0 C2 RAD specification drawing.

### USING A SPIRIT LEVEL TO ENSURE THAT THE SIDE TRACK IS ABSOLUTELY VERTICAL.

Similarly, cut the second track to the correct length, if necessary and repeat previous step ensuring that the side track is **ABSOLUTELY VERTICAL**.

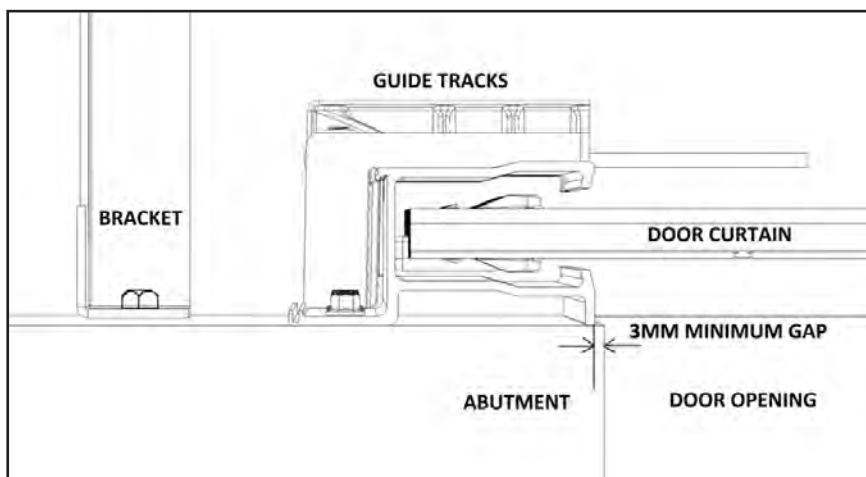

## 7.0 Stop Block Installation

Mark the hole position for stop block on bottom rail by maintaining 10mm away from the side edge of the Bottom Rail as shown below.

Drill 8mm through hole on bottom rail.

Locate the screw from the front of the bottom rail and secure the stop block to bottom rail using split washer and nut as shown below.

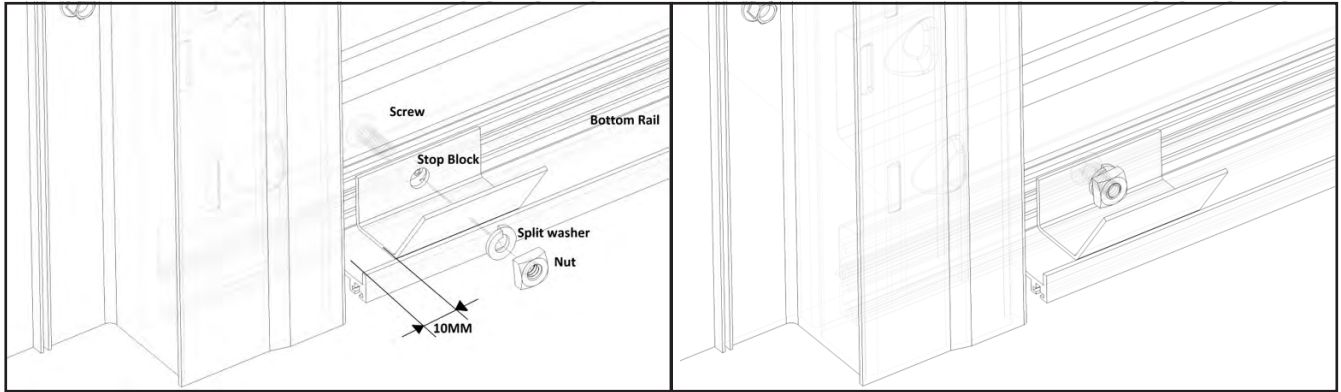

## 8.0 Final Adjustments

Adjust tracks for clearance, if necessary.

Adjust door for tension, if necessary (refer image).

If door does not roll up evenly and squarely, move the axle sideways on the mounting brackets until the door rolls up correctly.

Hold axle in the same way as described for tensioning, and re-tighten U Bolts.

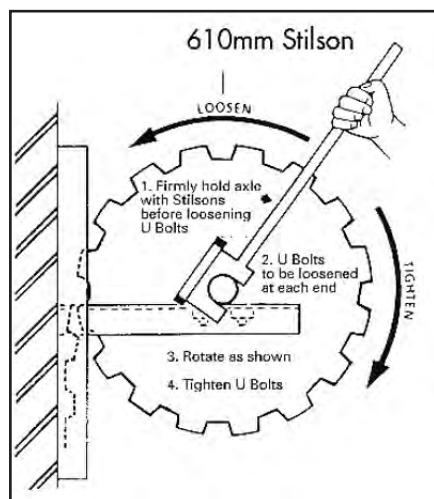



## 9.0 Fitting Locking Bar

With the door closed, and firmly seated on the floor, mark a point of contact between the locking bar and side tracks.

Drill a series of holes and file out the guide slot. A neat fit will minimize vibration and maintain efficiency of weatherseal.

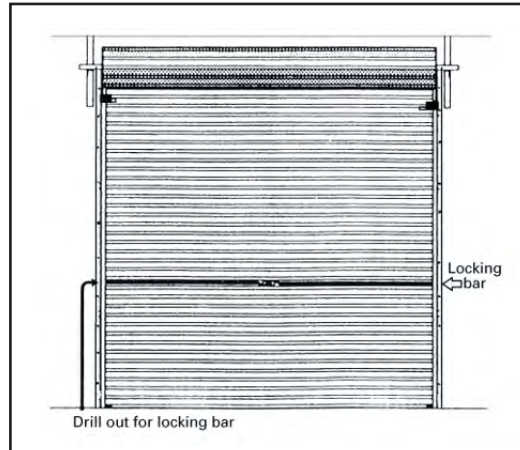

# 10.0 Reference Tables

**Table 1.0**

<b>Weight of Gliderol Aluminium Guide C2 Windlocked Roller Doors in Kilograms inc Guide Tracks</b>												
Door Size Height (mm)	A Series - Door Widths (mm)						AA Series - Door Widths (mm)					
	2490	2650	2800	3000	3050	3430	3710	3760	4370	5100	5200	5600
Up to 2100	56	59	61	64	67	73	77	95	107	121	126	134
2101 - 2400	66	69	72	76	79	86	91	96	108	122	127	135
2401 - 2695	67	70	73	77	80	87	92	110	124	141	146	155
2700 - 3000	81	84	88	92	99	108	114	123	137	154	166	175

**Table 1.1**

<b>Gliderol Aluminium Guide C2 Windlocked Roller Doors Maximum Pull Out Strength in KN (Universal A Series Bracket &amp; Standard AA Bracket)</b>												
Door Size Height (mm)	Width of Door (mm)											
	A Series - Door Widths (mm)						AA Series - Door Widths (mm)					
	2490	2650	2800	3000	3050	3430	3710	3760	4370	5100	5200	5600
Up to 2100	0.60	0.63	0.66	0.70	0.74	0.81	1.22	1.53	1.74	1.99	2.08	2.21
2101 - 2400	0.71	0.75	0.78	0.83	0.87	0.96	1.44	1.53	1.74	1.99	2.08	2.21
2401 - 2695	0.71	0.75	0.78	0.83	0.87	0.96	1.44	1.76	2.00	2.29	2.39	2.55
2700 - 3000	0.91	0.96	1.00	1.05	1.14	1.25	1.86	2.02	2.27	2.56	2.79	2.95

**Table 2.0**

<b>Weight of Gliderol Aluminium Guide C2 Windlocked Roller Doors in Kilograms inc Guide Tracks</b>											
Door Size Height (mm)	B Series - Width of Door (mm)										
	2200	2800	3100	3430	3710	3760	4370	5100	5200	5600	
Up to 2100 (5)	63	75	83	89	95	98	110	124	133	141	
2101 - 2400 (5)	64	76	84	90	96	99	111	125	134	142	
2401 - 2695 (6)	73	86	96	103	110	113	127	148	153	162	
2700 - 3300 (6)	82	96	109	117	123	130	149	166	178	187	
3301 - 3600 (7)	91	107	121	129	142	149	165	184	197	208	
3601 - 4200 (8)	101	118	139	149	157	165	183	204	218	230	
4201 - 5000 (9)	111	137	153	164	173	181	201	225	239	253	
5001 - 5600 (10)	121	149	167	179	189	197	219	246	260	274	

**Table 2.1**

<b>Gliderol Aluminium Guide C2 Windlocked Roller Doors Maximum Pull Out Strength in KN (Standard B Series Bracket)</b>										
Door Size Height (mm)	B Series - Width of Door (mm)									
	2200	2800	3100	3430	3710	3760	4370	5100	5200	5600
Up to 2100 (5)	63	75	83	89	95	98	110	124	133	141
2101 - 2400 (5)	64	76	84	90	96	99	111	125	134	142
2401 - 2695 (6)	73	86	96	103	110	113	127	148	153	162
2700 - 3300 (6)	82	96	109	117	123	130	149	166	178	187
3301 - 3600 (7)	91	107	121	129	142	149	165	184	197	208
3601 - 4200 (8)	101	118	139	149	157	165	183	204	218	230
4201 - 5000 (9)	111	137	153	164	173	181	201	225	239	253
5001 - 5600 (10)	121	149	167	179	189	197	219	246	260	274

# **11.0 Installation Faults and Remedies**

## **FAULTS**

1. Door hard to operate in one direction.
2. Door hard to operate in both directions.
3.
  - a) Door rolls up crooked.
  - b) Bottom rail of door rolls up out of parallel with roll of door.
  - c) Edge of roll is not flush, i.e. Door is rolling up in a spiral or cone shape.
4. Door is stiff to work and rattles over lead in top of guides.

## **REMEDIES**

1. Adjust spring tension.
2. Check guide clearance (see that door is not jamming).
3. For (a), (b) and (c):
  - (1) Check level of brackets.
  - (2) Axle may not be in centralized position - follow steps to adjust spring tension up to where it states axle can be rotated. Do not rotate unless spring tension is to be changed. While still retaining firm holding on axle, axle should be tapped in the direction of the spiraling (see diagram). Move no more than 10mm at a time. Then follow steps and secure axle.
4.
  - (1) Check that guides are not too long.
  - (2) Loosen one 'U'-bolt and push that side of door towards opening as far as possible, without scraping lintel. Tighten 'U'-bolt and repeat operations with other side, ensuring that axle is still parallel with opening.

# 12.0 Maintenance

## **Roller Door Curtain**

Gliderol roller door curtain is made up of colorbond prepainted steel which is highly durable and decorative finish. For maintenance regularly wash the curtain by fresh, clean water to enhance its life and maintain attractive finish. If this method does not remove all the dirt adhered on the surface please follow below procedure.

- Wash the surface of the roller door curtain with a mild solution of pure soap or mild non- abrasive kitchen detergent in warm water
- Application should be with a sponge, soft cloth or soft bristle nylon brush, and should be gentle to prevent shiny spots
- The roller door curtain surface should be thoroughly rinsed with clean water immediately after cleaning to remove traces of detergent

Caution: Never use abrasive or solvent type cleaners like turpentine's, petrol, kerosene, paint thinners to clean roller door surface as it may ruin the paint

## **Visual Inspection**

Conduct visual inspection of mounting brackets, springs, tracks, Guide lugs, fasteners, drive unit cables, weatherseal etc. for any wear and tear at least once in every six months.

- Springs should be lubricated using grease once in six months for proper functioning of the door and locking mechanism should be twice a year with general purpose oil or motor oil
- As Polyglide is self lubricated it is important NOT to lubricate the guides. It is advised from time to time to clean the guides with spirit cleaner and polish with car polish

IMPORTANT: DO NOT LUBRICATE GUIDE TRACKS.

## **Door Balance**

The roller door should be perfectly balanced for optimum performance and power consumption (for electric operation). Perform door balance test regularly at least once in six months to increase the efficiency of the roller door:

- Fully close the door
- If the door is operated electrically put it to manual operation by pulling the manual release pin (refer openers owners manual)
- Lift the door manually to waist height, say one metre above the floor level you should be able to lift the door with little effort and the door should stay open at that position
- If the door does not stay at that position (one metre) implies the door is out of balance. Get the door balanced by a Gliderol authorized service agent

# 13.0 Appendix

## Appendix 1.0 C2 RAD Specification Drawing

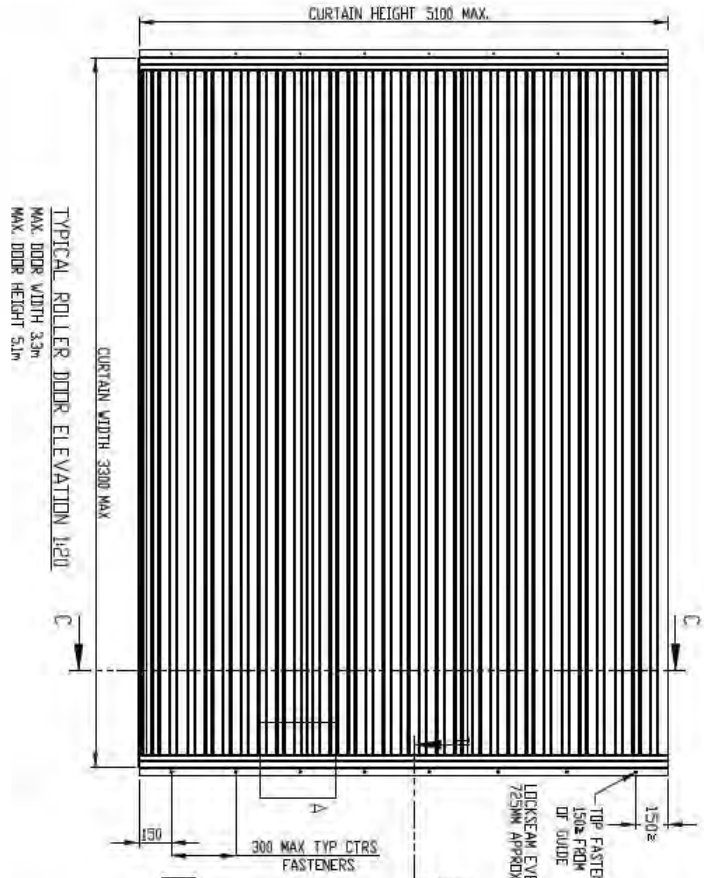

REACTIONS TO SUPPORTING GUIDES (kN/m) STRENGTH LIMIT STATE

CURTAIN WIDTH (m)	INWARD		OUTWARD	
	Rx	Ry	Rx	Ry
2400	12.04	3.33	13.89	-3.84
2700	14.32	3.77	16.76	-4.35
3000	17.12	4.20	19.80	-4.85
3300	19.26	4.64	22.23	-5.36

Rx = SHEAR FORCE PARALLEL TO DOOR OPENING  
Ry = NORMAL FORCE PERPENDICULAR TO DOOR OPENING  
INTERPOLATION IS PERMITTED FOR INTERMEDIATE WIDTHS

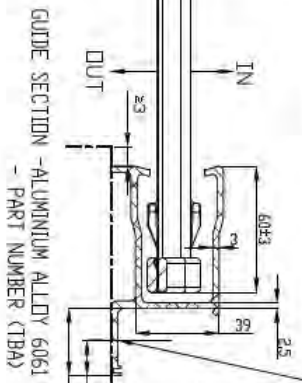

DETAIL A  
SCALE 1:1.5

**DESIGN CRITERIA NOTES:**

- DOMESTIC DOORS
- AS/ISO 5012
- CYCLONE REGION C
- TERRAIN CATEGORY 2
- NO SHELLING
- TOPGRAPHIC CLASS TO WIND CLASSIFICATION C2
- DOORS WITHIN ZONE G
- AS/NZS 4509:2002
- WIND CLASSIFICATION C2 - INWARD 292 kPa
- LIMITATIONS:
  - OUTWARD 337 kPa
  - STEEL FIRST TO BE 24MM (9/16") WITH MINIMUM YIELD STRENGTH GRADE OF 250MPa
- ALL DOOR COMPONENTS TO BE IN ACCORDANCE WITH GLIDEROL ROLLER DOOR SPECIFICATIONS
- DOORS TO BE LOCATED AT GROUND FLOOR
- CLASS 4 FINISH REQUIRED TO ALL TIE-ROD FIXINGS
- MECHANICAL BOLTS OR ANKASCREW FIXINGS TO BE GALVANIZED

**FIXING POINT**

- TIMBER FIX (GRABER SCREW WITH NG WASHER OR 14-10x65 SELF DRILLING SCREW WITH NG WASHER)
- STEEL FIX (M-10x65 SELF TAPPING SCREW)
- HOLLOW BRICK FIX/CONCRETE FILLED MIX FIX (900 DMM) OR EQUIVALENT
- SOLID BRICK FIX (900 DMM) OR EQUIVALENT (50MM MINIMUM EMBED)

DESIGN OF SUPPORTING STRUCTURE BY OTHERS

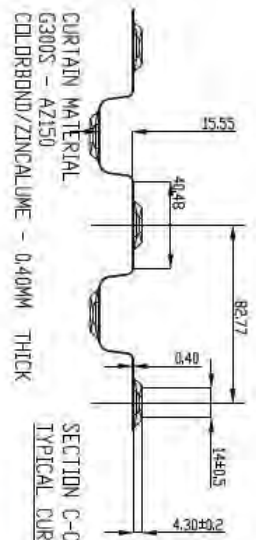

SECTION C-C  
TYPICAL CURTAIN MATERIAL 1:2

<p>THE INFORMATION CONTAINED HEREIN IS THE PROPERTY OF GLIDEROL GARAGE DOORS PTY LTD. IT IS TO BE USED ONLY FOR THE PROJECT AND SITE SPECIFICALLY REFERRED TO IN THIS DOCUMENT. IT IS NOT TO BE REPRODUCED OR TRANSMITTED IN ANY FORM OR BY ANY MEANS, ELECTRONIC OR MECHANICAL, INCLUDING PHOTOCOPYING, RECORDING, OR BY ANY INFORMATION STORAGE AND RETRIEVAL SYSTEM, WITHOUT THE WRITTEN PERMISSION OF GLIDEROL GARAGE DOORS PTY LTD.</p>	
<p>DATE: 15/08/2024</p> <p>BY: [Signature]</p> <p>FOR: [Signature]</p>	<p>PROJECT: [Signature]</p> <p>SCALE: 1:1</p>
<p>GLIDEROL garage doors</p>	

# **14.0 Warranty**

## **Manufacturers Product Warranties Statement**

Our goods come with guarantees that cannot be excluded under the Australian Consumer Law. You are entitled to a replacement or refund for a major failure and for compensation for any other reasonably foreseeable loss or damage. You are also entitled to have the goods repaired or replaced if the goods fail to be of acceptable quality and the failure does not amount to a major failure.

In addition, we offer our Gliderol Warranty as set out below. The benefits given to you by our Gliderol Warranty are in addition to other rights and remedies you may have under the Australian Consumer Law. Our Gliderol Warranty does not exclude, restrict or modify any such statutory rights or remedies which cannot be excluded.

For products sold and installed by Gliderol, the Gliderol Warranty extends to cover defects of manufacture and costs of delivery and/or re-installation of any product repaired or replaced under the terms of the Gliderol Warranty. In all other circumstances, where the products are supplied by a third party, the Gliderol Warranty covers defects of manufacture only and does not include costs of reinstallation or delivery.

This is not intended to exclude, restrict or modify any right or remedy to which you may otherwise be entitled in respect of delivery or re-installation under the Australian Consumer Law.

## **Schedule of Warranty Period for Individual Components**

Our Gliderol Warranty applies for the periods (the Applicable Warranty Period) stated as follows:

### Gliderol Storm-Safe Residential A, AA & B Series Roller Garage Door - C2 Version

Domestic/Residential use – 3 years corrosion free (not within 800 metres of a high salt concentration) on door curtain, excludes paint surface rubbing or fading. 3 month warranty on spring tension. 1 year on all components, labour & workmanship, if fitted by an authorised Gliderol Distributor or Gliderol Technician.

Industrial/Commercial use – 3 years corrosion free (not within 800 metres of a high salt concentration) on door curtain, excludes paint surface rubbing or fading. 1 year on all components, labour & workmanship, if fitted by an authorised Gliderol Distributor or Gliderol Technician. 3 month warranty on spring tension. 1 year on parts only, if fitted by parties other than an authorised Gliderol Distributor or Gliderol Technician. 1 year only if a Non Glidermatic operator is fitted to the door.

Gliderol strongly recommends that the Gliderol residential A, AA & B Series Roller Door be serviced by an authorised Gliderol Distributor or Gliderol Technician every 24 months to ensure longevity of the products life.

## Product Warranty Conditions

1. Subject to the following specific limitations and exceptions, and in addition to all rights and remedies to which you may be entitled under the Australian Consumer Law, Gliderol warrants all new doors, motors and electronic components of Gliderol's manufacture, sold and installed by Gliderol, to be free from defect in workmanship under normal use and service for the Applicable Warranty Period prescribed above.

2. During the Applicable Warranty Period, Gliderol will make good any defect as described in clause 1 above by repairing or replacing the affected product or part (at its option) PROVIDED THAT notice of any claimed defect in materials or workmanship in or resulting from installation of any door shall have been given to Gliderol within the period from date of installation as prescribed above.

3. For products sold through or installed by an authorised Gliderol Distributor or other party (other than an accredited Installer Contractor nominated by Gliderol), our Gliderol Warranty covers only defects of manufacture and does not include:-

- Any defects caused by or related to the installation of that product, nor
- The cost of delivering or re-installing a product that is repaired or replaced.

This limitation does not exclude, restrict or modify any right or remedy to which you may otherwise be entitled in respect of delivery or re-installation under the Australian Consumer Law or other applicable laws, which may not be excluded.

4. Our Gliderol Warranty does not apply to any defect, loss or damage arising or caused directly or indirectly by or as a result of:-

- (i) Any masonry rendered or other surfaces cracking or collapsing during installation of the door
- (ii) Any defect or deterioration of timber including drying out after installation
- (iii) Any weakening or collapse of the structure to which the doors are affixed occurring any time after installation
- (iv) Any damage to or deterioration in the condition of the doors occurring in transit by customer nominated or appointed carrier or occurring after delivery and prior to installation
- (v) Any defect (including defects in component parts or accessories) rising from or attributable to the failure to carry out normal preventive maintenance or adjustment
- (vi) To any additional defect damage or deterioration arising from or attributable to the operation of the door after it is known to be defective
- (vii) Any door being installed within 800 metres of the sea or other body of water of equivalent or greater salt concentration or in an area subject to industrial fall out Any automatic units exposed to moisture.
- (viii) Any fault or surge in customer's electricity supply
- (ix) The door striking an immovable object during travel

# Warranty Form

Name

Address

Product Type

Installation Date

Supplier (Distributor)

Installer

Phone No

Address

Installer Signature

NOTE: THIS FORM MUST BE COMPLETED BY THE INSTALLER AND PRODUCED AS PROOF OF PURCHASE DATE WHEN MAKING A SERVICE CALL UNDER WARRANTY, OTHERWISE CALLS ARE LIABLE TO SERVICE CHARGES.

**FOR SALES & SERVICE CONTACT GLIDEROL INTERNATIONAL PTY LTD (ABN 92 007 928 949)**

**Head Office**

Gliderol Garage Doors  
32 Jacobsen Crescent, Holden Hill SA 5088  
Phone (08) 8360 0000

**New South Wales**

Gliderol Garage Doors  
45 Sammut Street, Smithfield NSW 2164  
Phone (02) 9725 1033

**Victoria**

Gliderol Garage Doors  
94-98 Micro Circuit, Dandenong South VIC 3175  
Phone (03) 8788 8100

**Queensland**

Gliderol Garage Doors  
20 Randle Road, Pinkenba QLD 4008  
Phone (07) 3260 9000

**OR YOUR LOCAL SUPPLIER:**