

S800H ENC

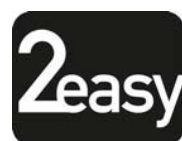
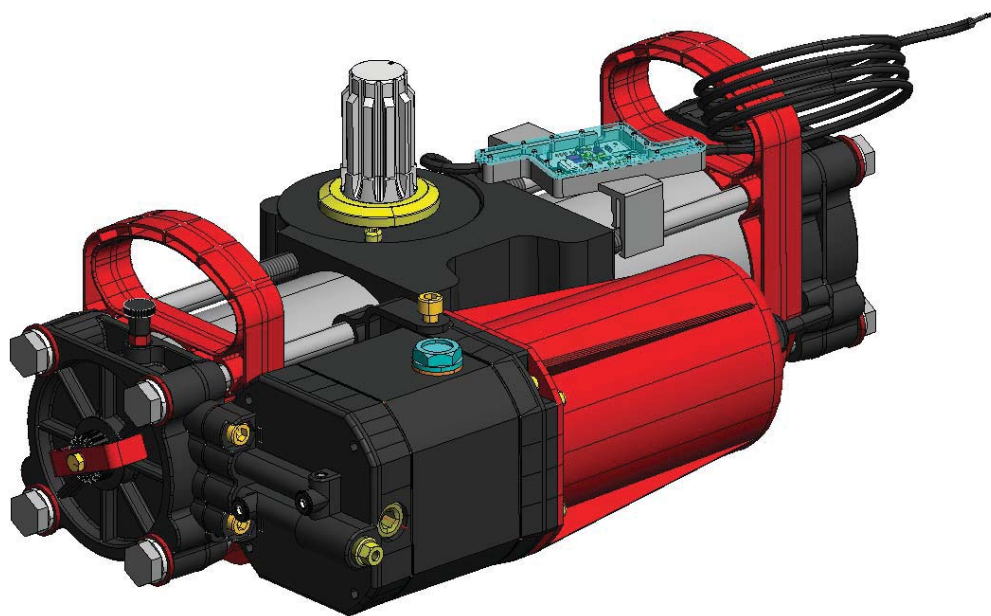

FAAC

AUTOMATED SYSTEM S800H ENC

WARNINGS FOR THE INSTALLER

GENERAL SAFETY OBLIGATIONS

- 1) **ATTENTION! To ensure the safety of people, it is important that you read all the following instructions. Incorrect installation or incorrect use of the product could cause serious harm to people.**
- 2) **Carefully read and follow the instructions before beginning to install the product.**
- 3) Do not leave packing materials (plastic, polystyrene, etc.) within reach of children as such materials are potential sources of danger.
- 4) Store these instructions for future reference.
- 5) This product was designed and built strictly for the use indicated in this documentation. Any other use, not expressly indicated here, could compromise the good condition/operation of the product and/or be a source of danger.
- 6) FAAC declines all liability caused by improper use or use other than that for which the automated system was intended.
- 7) Do not install the equipment in an explosive atmosphere: the presence of inflammable gas or fumes is a serious danger to safety.
- 8) The mechanical parts must conform to the provisions of Standards EN 12604 and EN 12605.
For non-EU countries, to obtain an adequate level of safety, the Standards mentioned above must be observed, in addition to national legal regulations.
- 9) FAAC is not responsible for failure to observe Good Technique in the construction of the closing elements to be motorised, or for any deformation that may occur during use.
- 10) The installation must conform to Standards EN 12453 and EN 12445.
For non-EU countries, to obtain an adequate level of safety, the Standards mentioned above must be observed, in addition to national legal regulations.
- 11) Before attempting any job on the system, cut out electrical power.
- 12) The mains power supply of the automated system must be fitted with an all-pole switch with contact opening distance of 3mm or greater. Use of a 6A thermal breaker with all-pole circuit break is recommended.
- 13) Make sure that a differential switch with threshold of 0.03 A is fitted upstream of the system.
- 14) Make sure that the earthing system is perfectly constructed, and connect metal parts of the means of the closure to it.
- 15) The automated system is supplied with an intrinsic anti-crushing safety device consisting of a torque control. Nevertheless, its tripping threshold must be checked as specified in the Standards indicated at point 10.
- 16) The safety devices (EN 12978 standard) protect any danger areas against **mechanical movement Risks**, such as crushing, dragging, and shearing.
- 17) Use of at least one indicator-light (e.g. FAACLIGHT) is recommended for every system, as well as a warning sign adequately secured to the frame structure, in addition to the devices mentioned at point "16".
- 18) FAAC declines all liability as concerns safety and efficient operation of the automated system, if system components not produced by FAAC are used.
- 19) For maintenance, strictly use original parts by FAAC.
- 20) Do not in any way modify the components of the automated system.
- 21) The installer shall supply all information concerning manual operation of the system in case of an emergency, and shall hand over to the user the warnings handbook supplied with the product.
- 22) Do not allow children, things or adults to stay near the product while it is operating.
- 23) Keep remote controls or other pulse generators away from children, to prevent the automated system from being activated involuntarily.
- 24) Transit is permitted only when the automated system is idle.
- 25) The user must not attempt any kind of repair or direct action whatever and contact qualified personnel only.
- 26) Maintenance: check at least every 6 months the efficiency of the system, particularly the efficiency of the safety devices (including, where foreseen, the operator thrust force) and of the release devices.
- 27) **The S800H ENC automated system automates vehicle entrances - pedestrians must have a separate entrance.**
- 28) Power up the automated system only when expressly indicated.
- 29) **Anything not expressly specified in these instructions is not permitted.**

EC DECLARATION OF CONFORMITY

The Manufacturer

Company name:

FAAC S.p.A.

Address:

Via Calari, 10 - 40069 Zola Predosa BOLOGNA - ITALY

hereby declares that the following products:

Description:

Underground operator for swing leafs gates

Model:

S800H ENC

comply with the following applicable EU legislations:

- EMC Directive 2004/108/EC
- ROHS Directive 2 2011/65/UE

Furthermore, the following harmonised standards have been applied:

- EN EN 60335-2-97:2006
- EN 61000-6-2:2005
- EN ISO 12100:2010
- EN 61000-6-3:2007

Bologna, 22-01-2015

CEO
A. Marcellan



DECLARATION OF INCORPORATION OF PARTLY COMPLETED MACHINERY

(2006/42/CE ANN.II P.1, LETT. B)

Manufacturer and person authorised to prepare the relevant technical documentation

Company name: FAAC S.p.A.
Address: Via Calari, 10 - 40069 Zola Predosa BOLOGNA - ITALY

hereby declares that for the partly completed machinery:

Description:

Model: S800H ENC

the essential requisites of the Machinery Directive 2006/42/EC (including all applicable amendments) applied and met are:

RESS 1.1.2,1.1.3,1.1.4,1.1.5,1.1.6,1.2.1,1.3.1,1.3.2,1.5.1,1.5.4,1.5.9,1.5.13,1.6.3,1.7.1,1.7.2, 1.7.4
 and that the relevant technical documentation has been compiled in compliance with part B of Annex VII.

Furthermore, the following harmonised standards have been applied:

- EN ISO 12100:2010
- EN 60335-1:2013
- EN EN 60335-2-97:2006

It is also hereby declared that the partly completed machinery identified above may not be commissioned until the final machine - into which it will be incorporated - has been declared to conform to the provisions of the above mentioned Machinery Directive 2006/42/EC.

Bologna, 22-01-2015

CEO
 A. Marcellan *[Signature]*

ENGLISH

Translation of the original instructions

1 DESCRIPTION

These instructions apply to the following models: S800H ENC SB/SBW - S800H ENC CBAC / 100° - 180°.

FAAC S800H ENC is an automation in a hydraulic monobloc (CLASS III), for the access of vehicles through swing gates. Retractable in the ground, it does not change the looks of the gate. The model equipped with hydraulic lock does not require installation of the electric lock, mechanically locking the leaf, up to 2 m, when the motor is not running. The model without hydraulic lock always requires one or more electric locks to guarantee mechanical locking of the leaf.

S800H ENC automations are designed and built to automate swing gates. They must not be used in any other way.

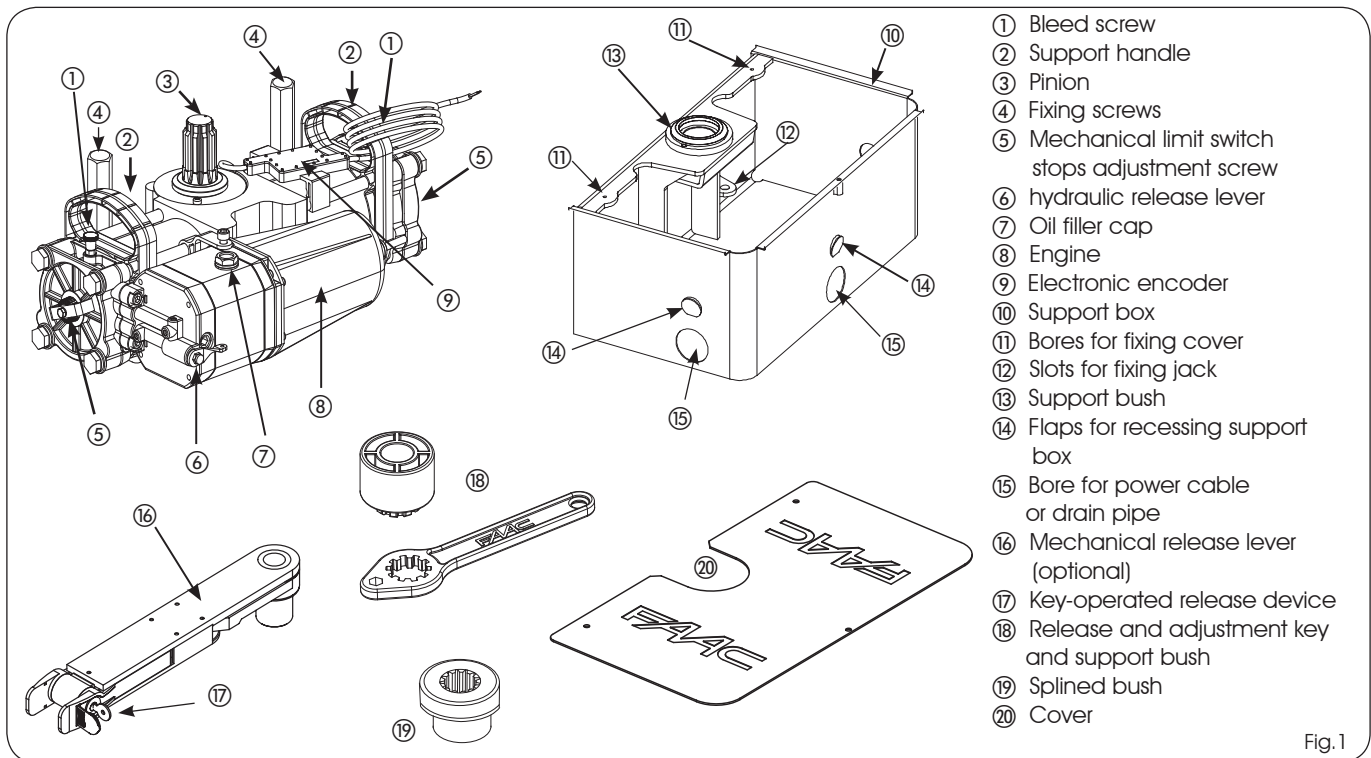

Fig.1

2 TECHNICAL FEATURES

TECHNICAL FEATURES	CBAC OPERATOR	OPERATOR SB/SBW
Power supply (V=)	24	
Absorbed power (W)	60 (*)	
Protection rating	IP 67	
Oil type	"FAAC HP OIL"	
Operating temperature	-20° C +55° C	
Rated Operating Time (R.O.T.)	Continuous duty at 55° C	
Hydraulic lock	Included	Not included
Max torque (Nm) **	500 (E024S) ; 600 (E124)	

Angular speed (°/sec) ***	5.5 (E024S) ; 8.2 (E124)	
Max opening angle ****	113° (S800H ENC 110°) 187° (S800H ENC 184°)	
Max leaf length (m)	2	4 (electric lock mandatory)
Max leaf weight (kg)	800	

* EACH INDIVIDUAL OPERATOR
 ** CONSIDERING 55 Bar OF STATIC PRESSURE IN THE CHAMBERS
 *** CONSIDERING A PUMP FLOW RATE OF 0.6 lpm
 **** 3° OF STROKE IS LOST DURING INSTALLATION OF THE OPERATOR

3 ELECTRICAL SET-UP

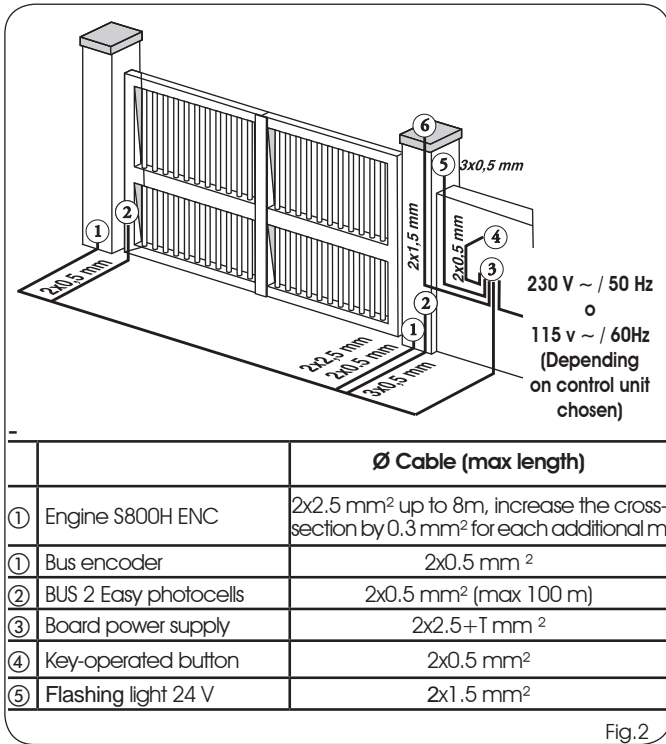

4 INSTALLATION OF THE OPERATOR

4.1 OPERATOR WITHOUT EMERGENCY MECHANICAL RELEASE

- 1) Bring the gate to the open position.
- 2) Referring to the instructions in chapter 7.1, act on the operator's hydraulic release by turning the lever (Fig.1 ref.⑥) or using the specific key (Fig.1 ref.⑩) turn the release screw (Fig.3 ref.①).

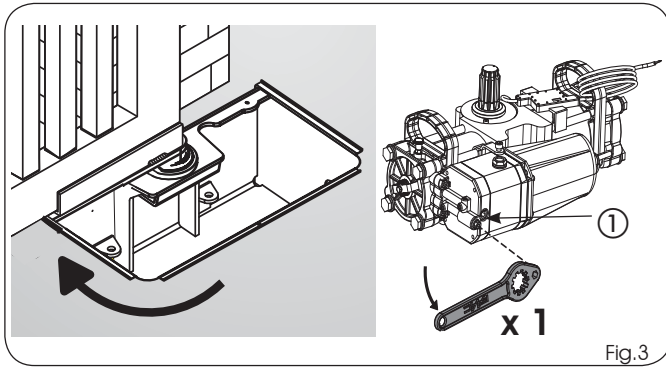

- 3) Unscrew the cap (Fig.4 ref.A) on the screw of the closing limit switch (Fig.4 ref. ①), and make sure that the screw is tightened all the way.
- 4) **Loosen the screw of the closing limit switch (Fig.4 ref.B) by one turn (Important to correctly couple the pinion-splined bush during installation).**
- 5) Turn the pinion of the operator using the supplied key (Fig.5 ref.①), **in the direction the gate closes**, until it reaches the internal stop of the piston and remove the key.

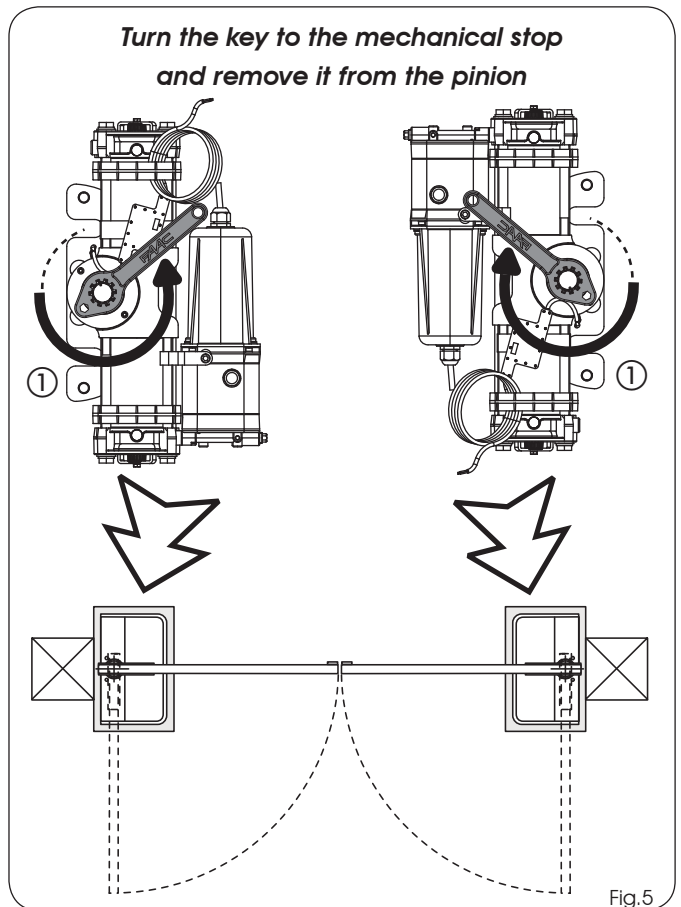
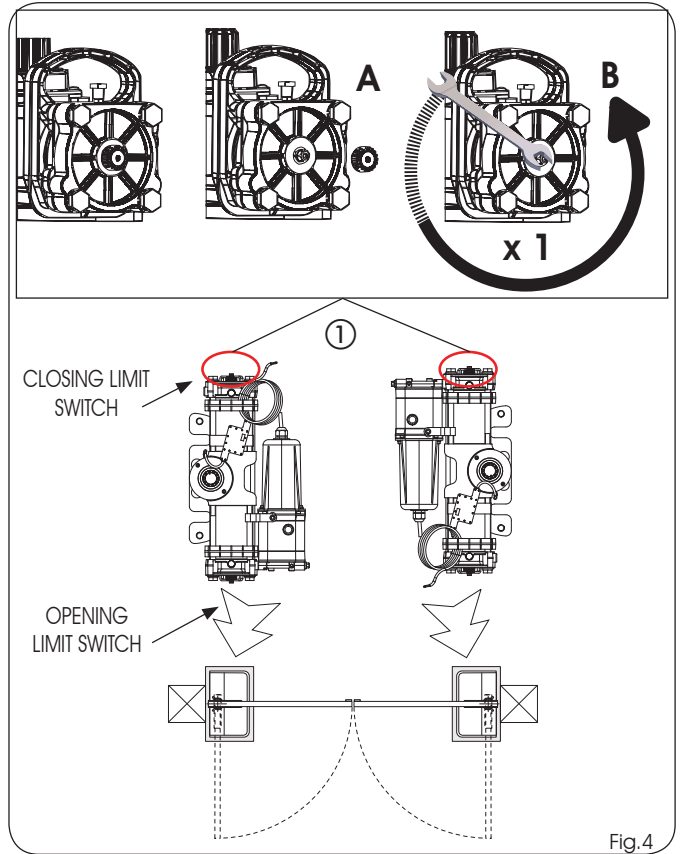

- 6) **Without moving the pinion** insert the supplied key on the operator (**Check the position of the pin on the pinion Fig.6 ref.①**), and if needed turn the pinion to correct it (**Important to correctly couple the pinion-splined bush during installation**).
- NOTE: if necessary, screw the closing limit switch screw slightly.

Insert the key without moving the pinion and check that it is at the following position

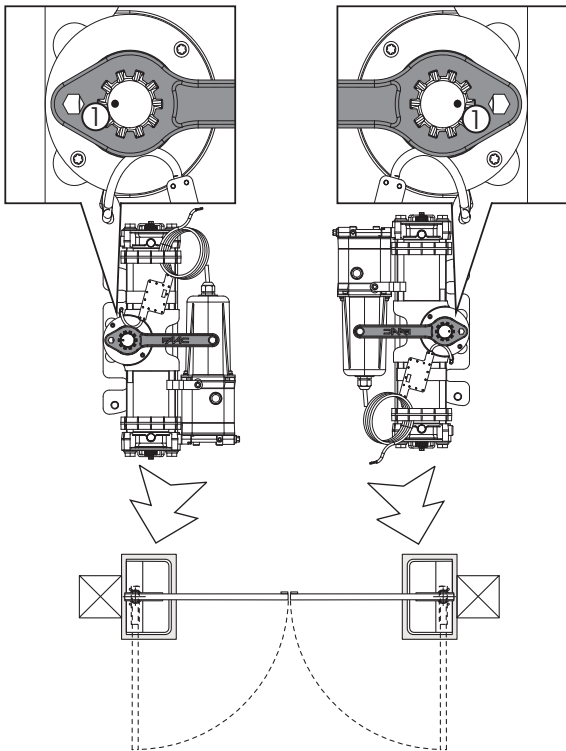

Fig.6

- 7) Remove the adjustment key, screw the cap of the limit switch and grease the operator pinion.
- 8) Using the specific handles, insert the operator in the support box figure 7, and position it as shown in figure 8 A, B.
- 9) Close the gate (Fig.9).

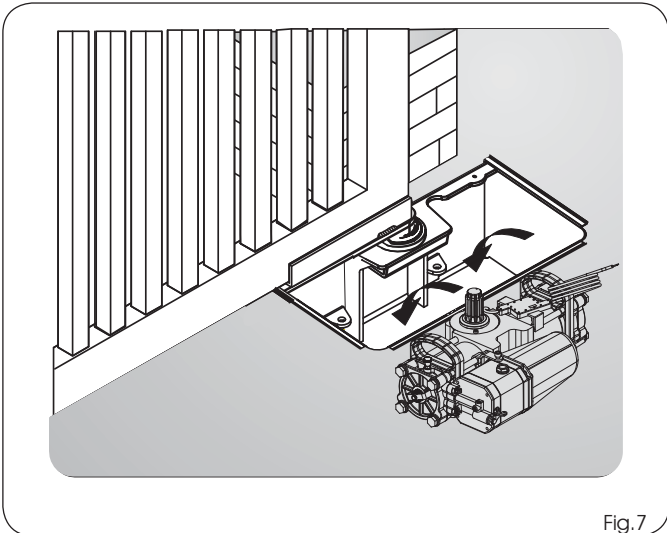

Fig.7

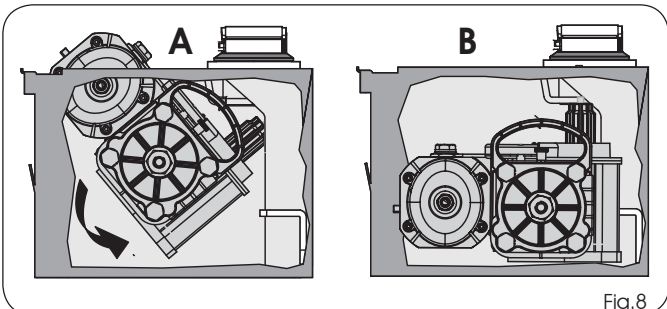

Fig.8

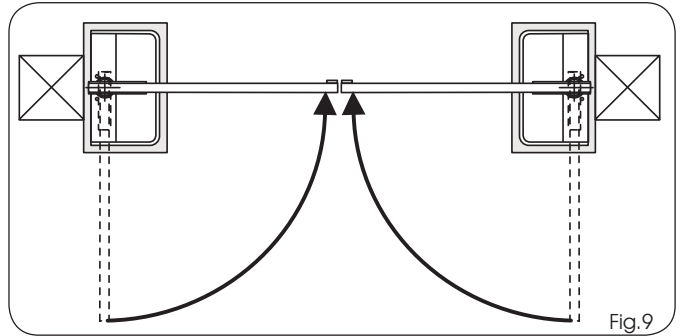

Fig.9

- 10) Lift the operator using the specific panels (Fig.10 ref.A), and insert the pinion in the splined bush of the support box. To facilitate the operation, turn the operator until they couple.
- 11) Position the supplied key beneath the operator as shown in figure 10 ref. B to support the engine.
- 12) Insert and screw the fixing screws with the groove as shown in figure 10 ref. C, to secure the operator to the support box, as in figure 11.
- 13) Open and close the gate, checking the respective limit switches, as described in chapter 5, and adjust them if necessary.
- 14) Hydraulically lock the operator according to the instructions in chapter 7.1.
- 15) Perform the electrical connections, as described in the instructions of the electronic equipment, paying attention to the polarity of the encoder.

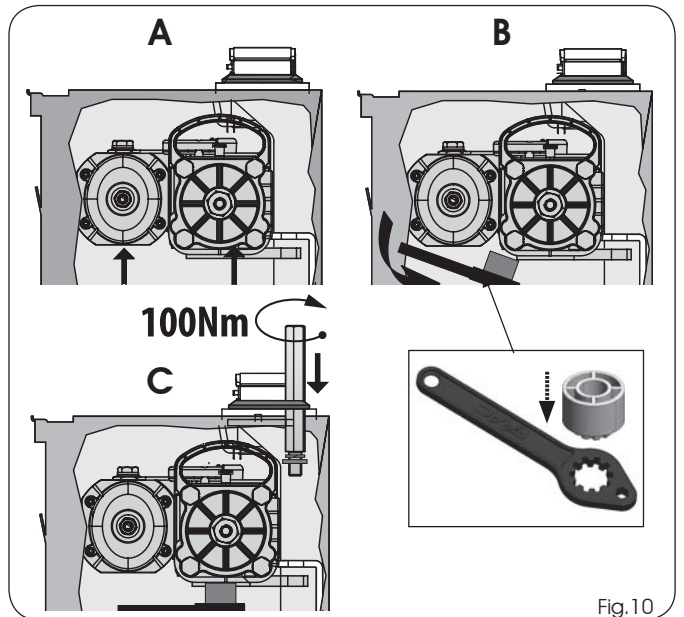

Fig.10

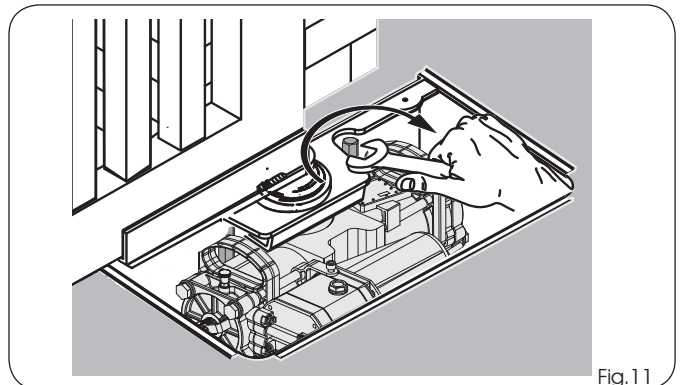
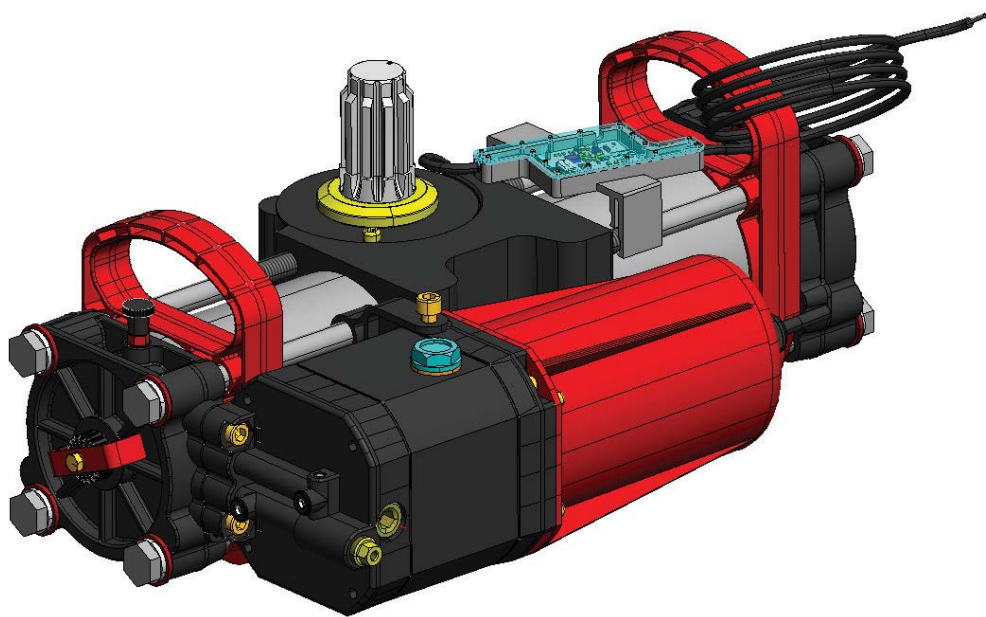
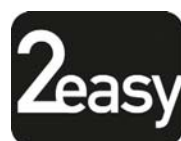

Fig.11

S800H ENC



Inserto Immagini - Pictures Collection
Collection de Figures - Photo Kollektion
Inserto imágenes - Fotoverzameling



FAAC

CASSETTA PORTANTE-SUPPORT BOX-CAISSON PORTANT GEHÄUSE-CAJA PORTANTE-BEHUIZING

Quote in mm - Dimensions in mm - Cotes en mm - Maße in mm - Cotas en mm - Waarden in mm

ITALIANO

ENGLISH

FRANÇAIS

DEUTSCH

ESPAÑOL

NEDERLANDS

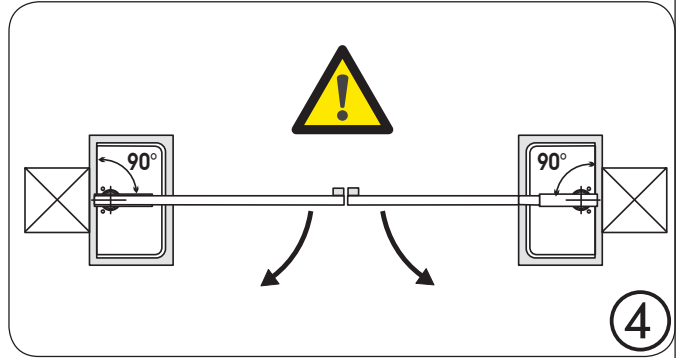
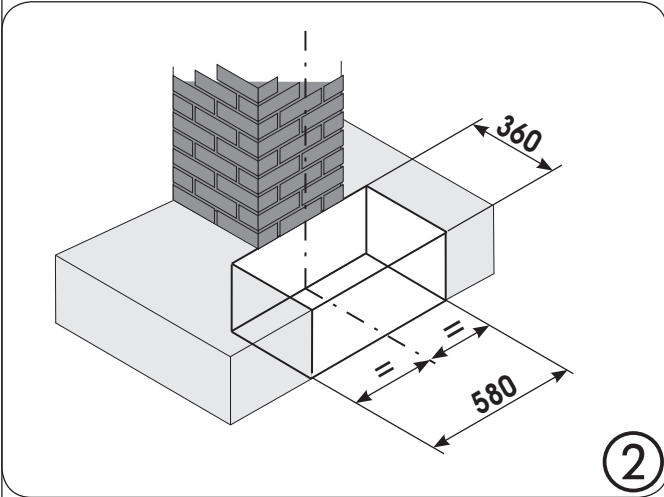
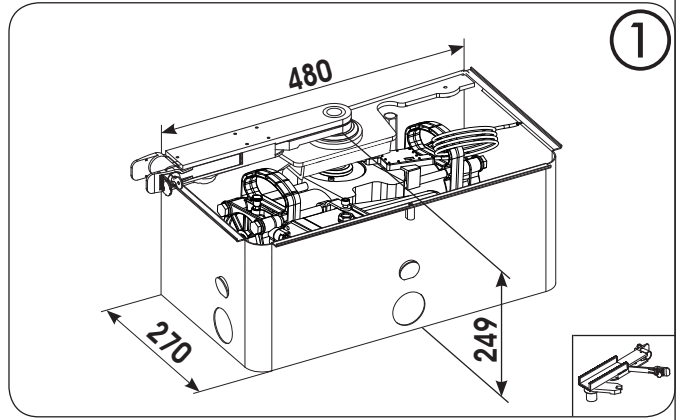
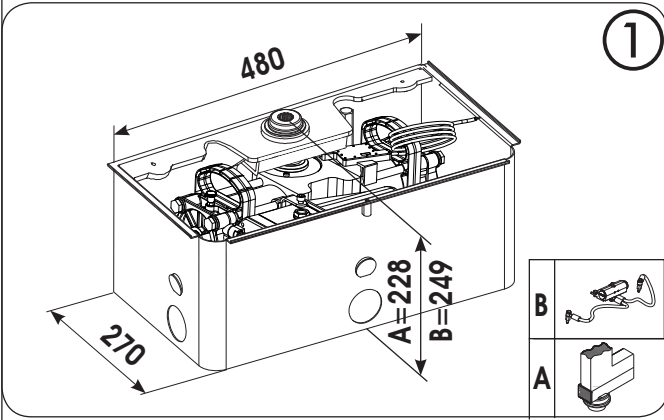

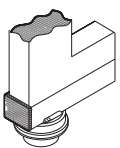
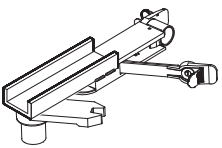
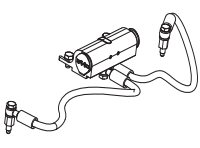
A (mm)		
		
26	47	

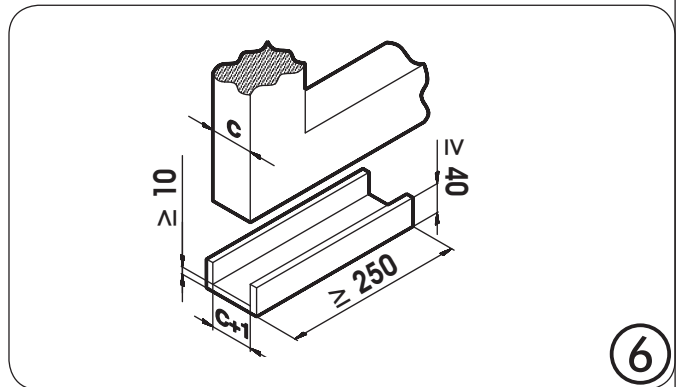
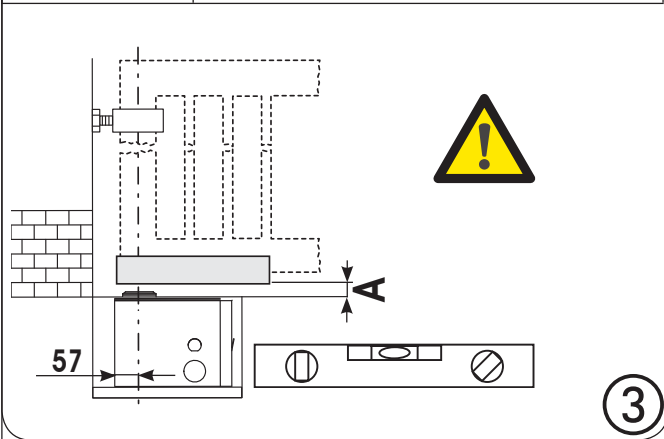
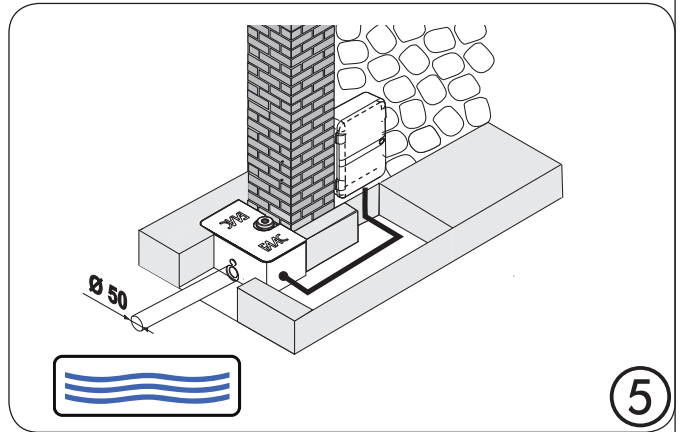

S800H ENC

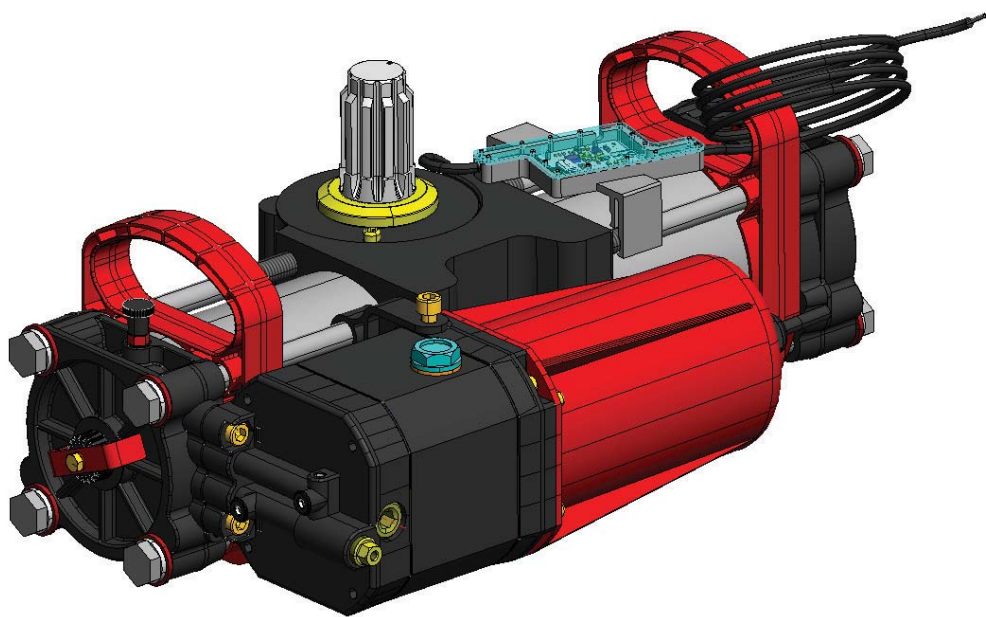

Guida per l'utente - User's guide
Guide pour l'utilisateur - Anleitungen für den Benutzer
Guía para el usuario - Gebruikersgids

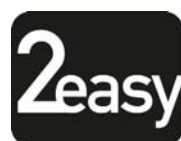

FAAC

AUTOMATION

USER'S GUIDE

GENERAL SAFETY STANDARDS

If installed and used correctly, the automation guarantees a high degree of safety.

Some simple standards of conduct can help avoid accidental problems:

- Do not pass through the leaves when they are moving. Wait for them to be completely open before passing through.
- Do not stop between the leaves.
- Do not stop and do not allow children, persons or objects to stop in the vicinity of the automation, especially while it is running.
- Do not allow children to play with the automation. Guard the radio controls and any other pulse generator to keep the automation from being activated unintentionally.
- Do not intentionally hinder the movement of the leaves.
- Do not allow branches or shrubbery to interfere with the movement of the leaves.
- Keep the indicator light systems efficient and well visible.
- Do not try to move the leaves by hand unless you have released them.
- In the case of a malfunction, release the leaves to permit access and wait for the technical intervention of qualified personnel.
- Once manual operation has been set, disconnect power to the system before restoring normal operation.
- Do not modify the components of the automation system in any way.
- Do not attempt any kind of repair or direct intervention and only contact qualified personnel.
- Have the efficiency of the automation and of the safety devices checked at least every six months by qualified personnel.

DESCRIPTION

These instructions apply to the following models:

S800H ENC CBAC - S800H ENC SB/SBW

The swing gate automation is a hydraulic monobloc which, installed retractable in the ground, does not change the looks of the gate.

The model equipped with hydraulic lock does not require installation of the electric lock, mechanically locking the leaf when the motor is not running. The model without hydraulic lock always requires one or more electric locks to guarantee mechanical locking of the leaf.

S800H ENC automations are designed and built to automate swing gates. They must not be used in any other way.

Regarding the chosen model, the system can automate leaves up to 4 m and 800 kg.

The operators are managed by an electronic control unit, inside an enclosure with an appropriate protection rating against atmospheric agents. The leaves normally touch when they are closed. When the electronic control unit receives an opening command via the radio control or any other pulse generator, this activates the hydraulic device which makes the leaves rotate to an opening position permitting access.

If set to automatic mode, the leaves close on their own after a selected pause time.

If in semi-automatic mode, a second pulse must be sent for them to close.

A stop pulse (if foreseen) always stops movement.

For the detailed behaviour of the automation in the different operating conditions, refer to the Installer technician.

The automation has type D safety devices (photocells) which impair leaf movement when there is an obstacle in the area they protect.

The S800H ENC has, as standard, a device which, connected to an appropriate electronic appliance, detects the presence of an obstacle and reverses the running direction of the leaves. The indicator light indicates that the leaves are moving.

MANUAL OPERATION



Warning: Before performing the **RELEASE** or **LOCK** operations, make sure power has been disconnected to the operator.

HYDRAULIC RELEASE OF THE OPERATOR

If you need to move the gate by hand due to a power failure or a malfunction in the automation, act on the hydraulic release device by means of the specific lever or release key:

- 1) Remove the cover from the support box
 - 2) Act on the release screw (Fig.1 ref.①), (if there is no lever, insert the hexagonal recess of the supplied key (Fig.2 ref.②)):
- To **RELEASE**, turn the screw one turn anticlockwise (to keep oil from escaping).
 - To **RELOCK**, turn the screw clockwise to the mechanical stop.

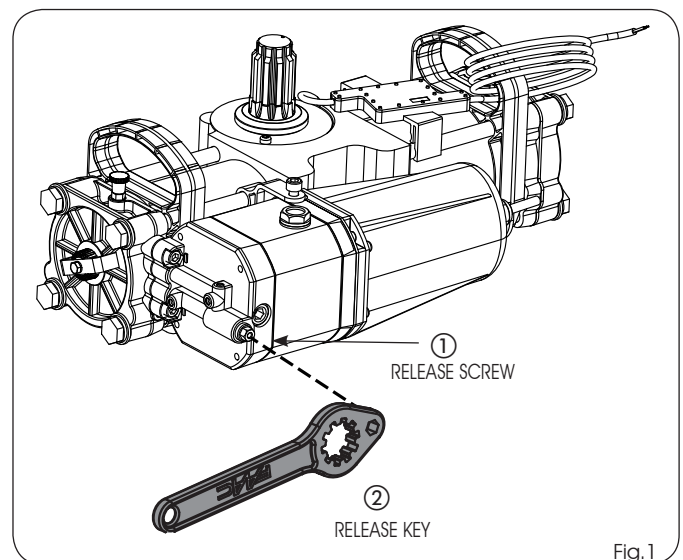

EMERGENCY HYDRAULIC RELEASE (OPTIONAL)

The operator has an optional manual emergency hydraulic release (Fig.2).

You must act on the key-operated release device when needing to move the gate by hand without accessing the foundation box. The device is installed at the base of the gate and allows you to release the system.

Proceed as follows to move the leaf by hand:

- 1) To release, insert the key in the lock and turn it anticlockwise to the mechanical stop.
- 4) Move the leaf by hand.

Proceed as follows to restore the system to normal operation (from gate released):

- 1) To relock, insert the key in the lock and turn it clockwise until the stop.

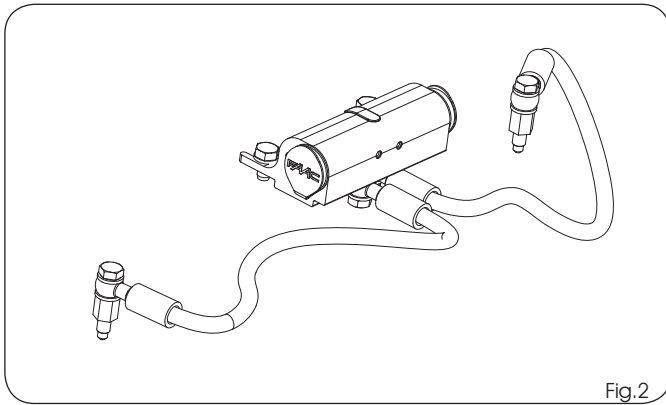

EMERGENCY MECHANICAL RELEASE (OPTIONAL)

The operator has an optional manual emergency mechanical release (Fig.3).

If you need to move the gate by hand due to a power failure or a malfunction in the automation, act on the key-operated release device.

The device is installed on the support bracket of the gate and makes it possible to release the system both from inside and outside the property.

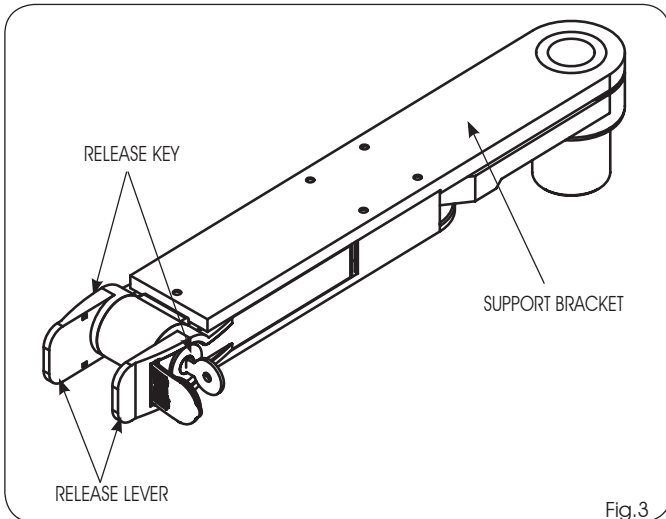

Proceed as follows to move the leaf by hand:

- 1) Open the protective cover (Fig.4 ref. ②).
- 2) Insert the release key in the lock (Fig.4 ref. ③) and turn it clockwise to the stop.
- 3) Pull the release lever towards you (Fig.4 ref. ①).
- 4) Move the leaf by hand.

Proceed as follows to restore the system to normal operation (from gate released):

- 1) Put the release lever back to its home position (Fig.3).
- 2) Insert the release key in the lock and turn it clockwise to the stop.
- 3) Move the leaf by hand until it hooks the lock on the locking bracket.
- 4) Close the protective cap of the lock.

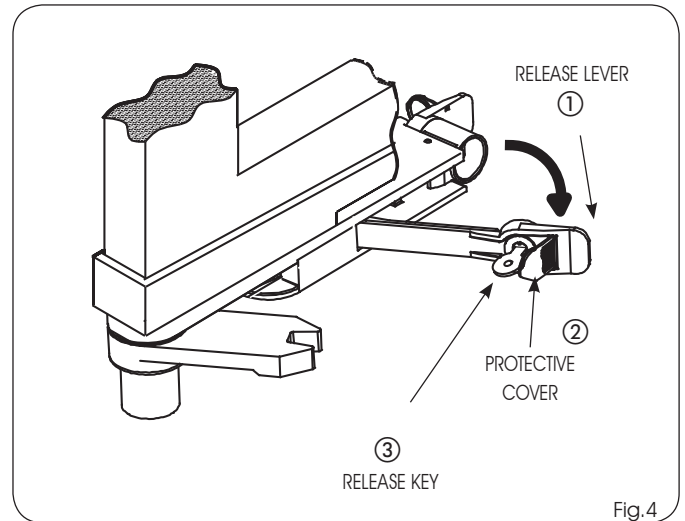

MAINTENANCE

Have a qualified technician perform a functional check of the system every six months, paying special attention to the efficiency of the safety and release devices and to perfect functioning of the gate hinges.

Also have the amount of oil in the tank checked. **Use only "FAAC HP OIL" for topping up.**



www.faacgroup.com

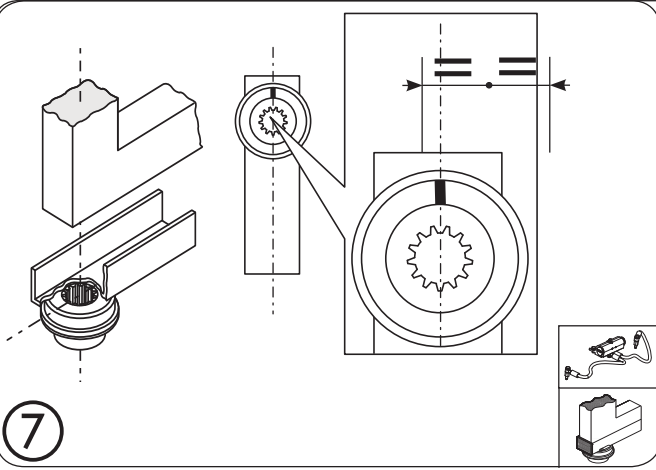

7



PER GARANTIRE UNA CORRETTA INSTALLAZIONE OCCORRE CHE L'ASSE DI ROTAZIONE DELL'ANTA, SIA PERFETTAMENTE ALLINEATO CON L'OPERATORE (Fig. 7)

TO GUARANTEE CORRECT INSTALLATION, THE ROTATION AXIS OF THE LEAF MUST BE PERFECTLY ALIGNED WITH THE OPERATOR (Fig. 7)

POUR GARANTIR UNE INSTALLATION CORRECTE, IL FAUT QUE L'AXE DE ROTATION DU VANTAIL SOIT PARFAITEMENT ALIGNÉ AVEC L'OPÉRATEUR (Fig. 7)

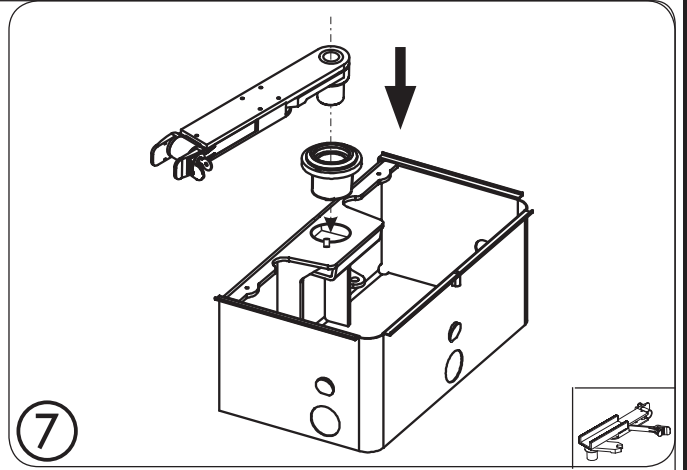

7

ZUR GEWÄHRLEISTUNG EINER SACHGEMÄSSEN MONTAGE MUSS DIE DREHACHSE DES TORFLÜGELS PERFECT ZUM ANTRIEB GEFLUCHTET SEIN (Abb. 7)

PARA GARANTIZAR UNA CORRECTA INSTALACIÓN EL EJE DE ROTACIÓN DE LA HOJA DEBE ESTAR ALINEADO PERFECTAMENTE RESPECTO AL OPERADOR (Fig. 7)

OM EEN CORRECTE INSTALLATIE TE GARANDEREN MOET DE ROTATIE-AS VAN DE POORTVLEUGEL PERFECT OP EEN LIJN MET HET BEDIENINGSSYSTEEM ZIJN (Fig. 7)

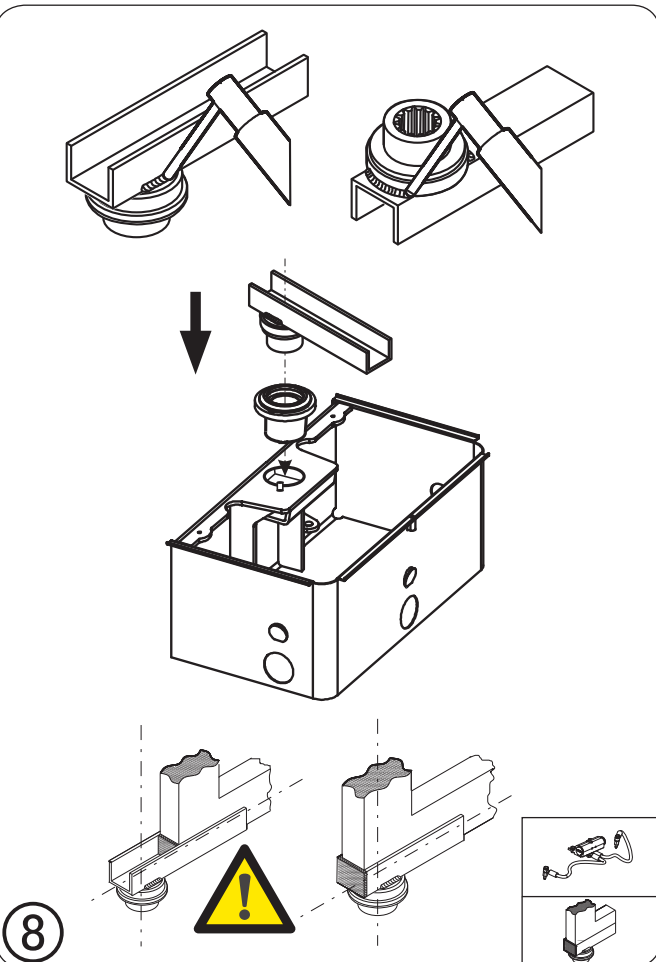

8

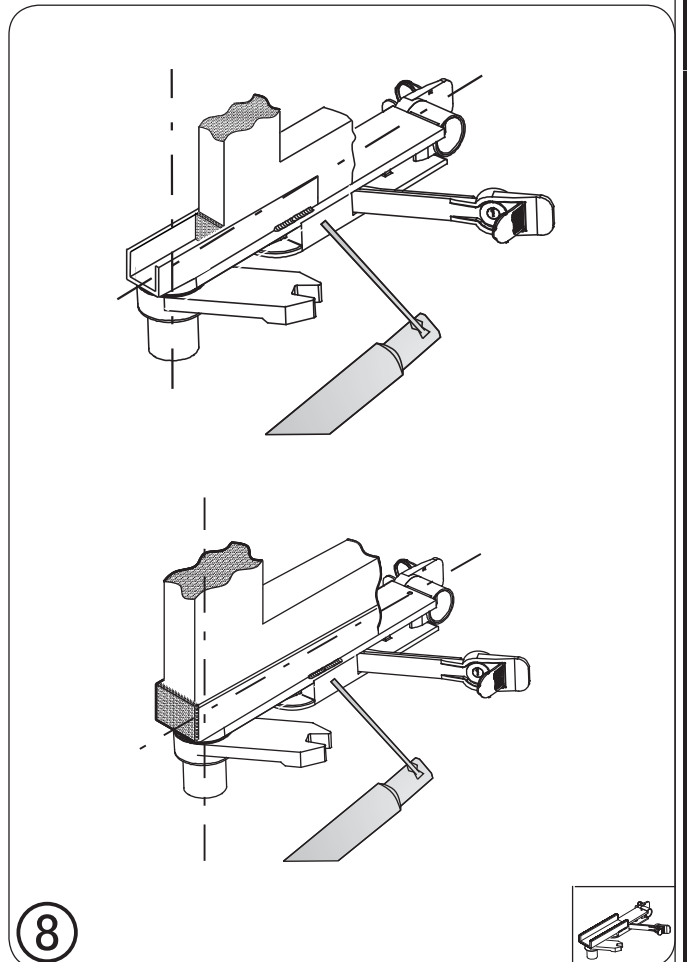

8

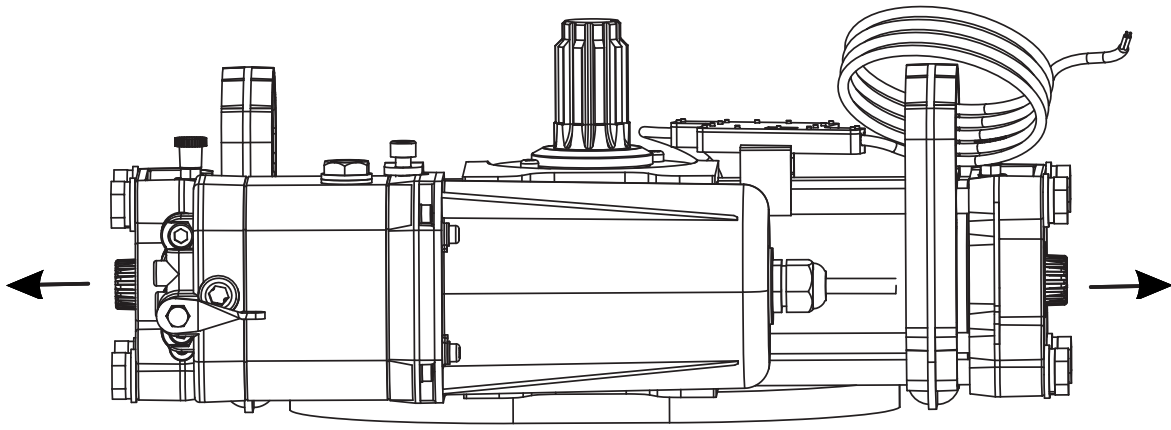

9

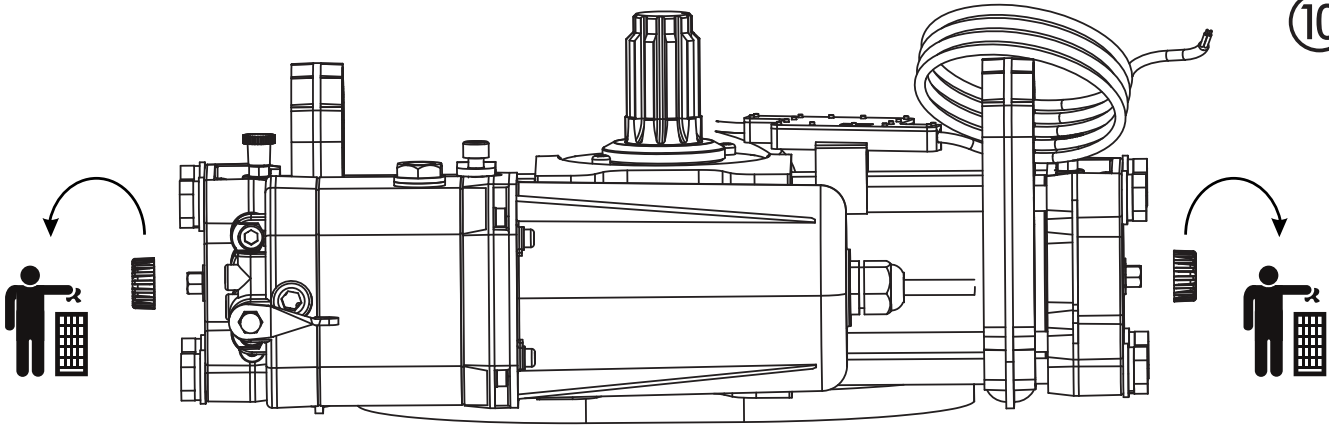

10

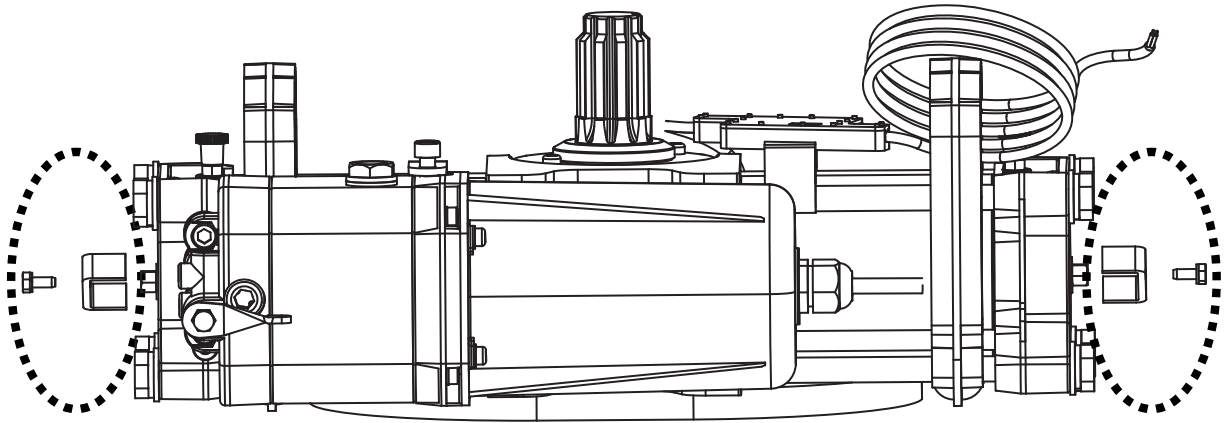

11

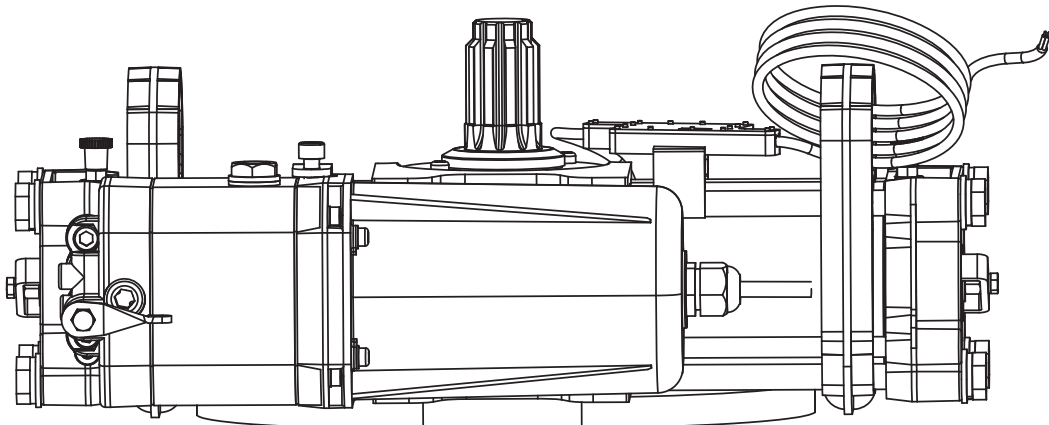

12

4.2 OPERATOR WITH EMERGENCY MECHANICAL RELEASE

- 1) Bring the gate to the open position.
- 2) Referring to the instructions in chapter 7.1, act on the operator's hydraulic release by turning the lever (Fig.1 ref.⑥) or using the specific key (Fig.1 ref.⑱) turn the release screw (Fig.12 ref.①).

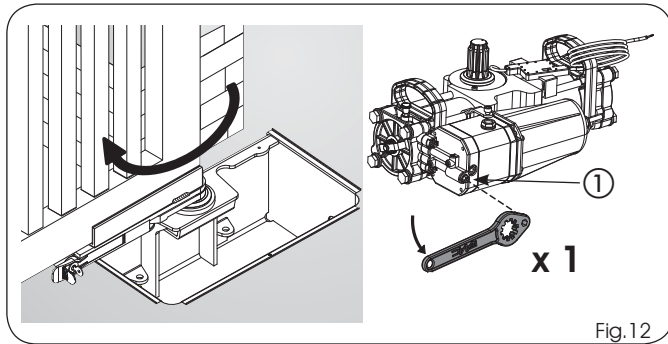

Fig.12

- 3) Unscrew the cap (Fig.13 ref.A) on the screw of the closing limit switch (Fig.13 ref. ①), and make sure that the screw is tightened all the way.
- 4) Loosen the screw of the closing limit switch (Fig.13 ref.B) by one turn (Important to correctly couple the pinion-splined bush during installation).

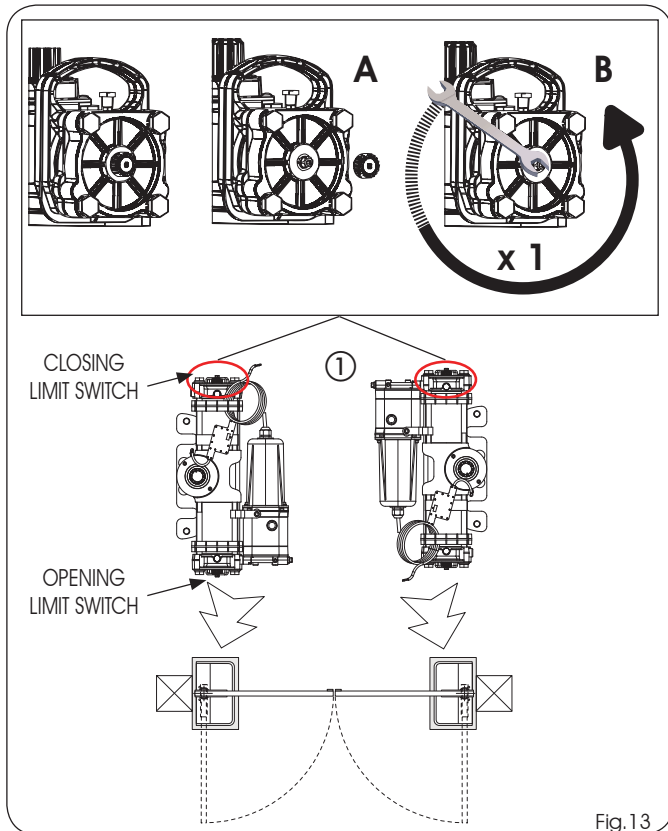

Fig.13

- 5) Turn the pinion of the operator using the supplied key (Fig.14 ref.①), in the direction the gate closes, until it reaches the internal stop of the piston and remove the key.
- 6) Without moving the pinion insert the supplied key on the operator (Check the position of the pin on the pinion Fig.15 ref.①), and if needed turn the pinion to correct it (Important to correctly couple the pinion-splined bush during installation).
NOTE: if necessary, screw the closing limit switch screw slightly.

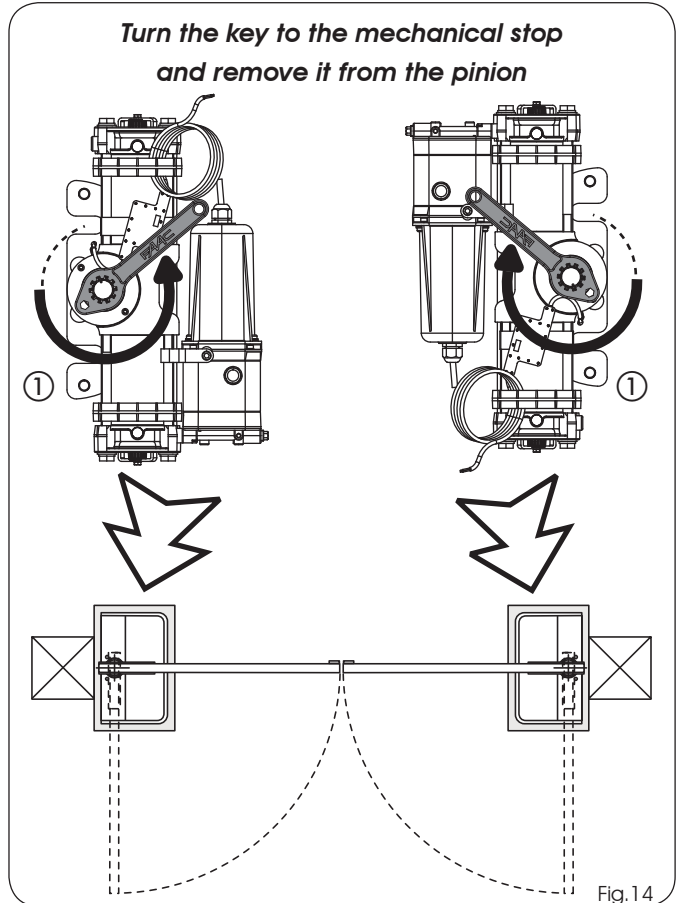

Fig.14

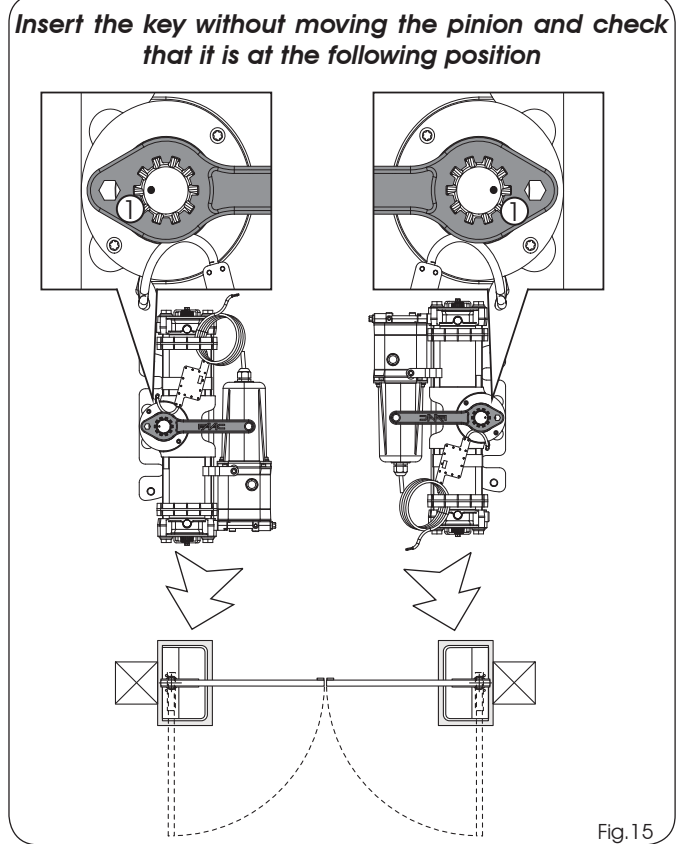

Fig.15

- 7) Remove the adjustment key, screw the cap of the limit switch screw and grease the operator pinion.
- 8) Using the specific handles, insert the operator in the support box figure 16, and position it as shown in figure 17 A, B.
- 9) Close the gate (Fig. 18).
- 10) Free the mechanical release (fig. 19) referring to paragraph 7.2 .

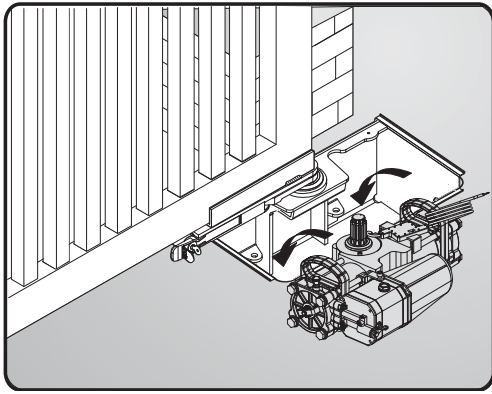

Fig.16

12) Lift the operator using the specific panels (Fig.21 ref.A), and insert the pinion in the splined bush of the support box. To facilitate the operation, turn the operator until they couple.

13) Place the supplied key beneath the operator (Fig.21 ref. B) to support the engine.

14) Insert and screw the fixing screws with the groover (Fig.21 ref. C, to secure the operator to the support box, as in figure 22.

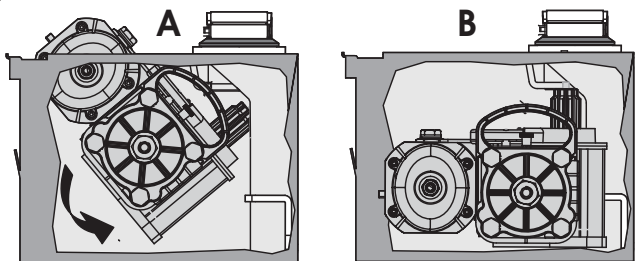

Fig.17

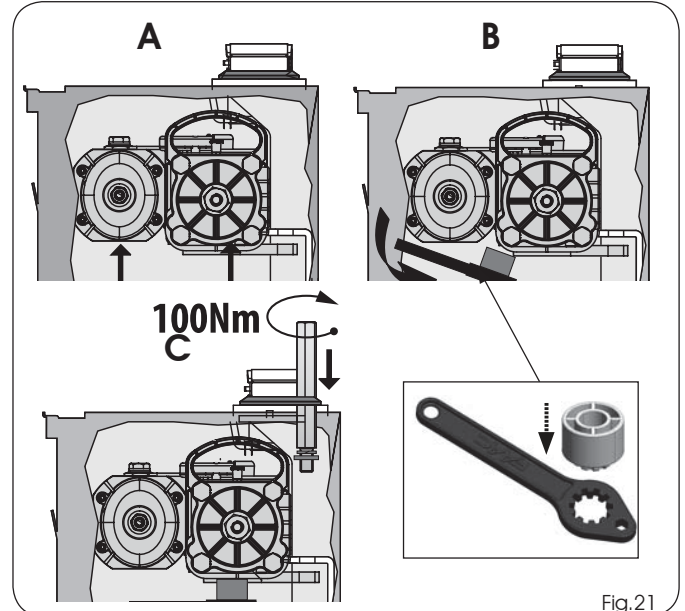

Fig.21

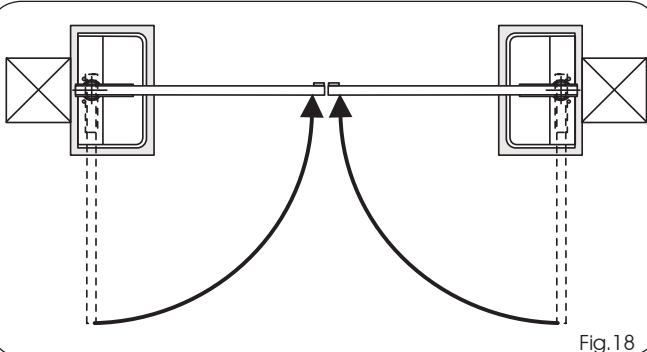

Fig.18

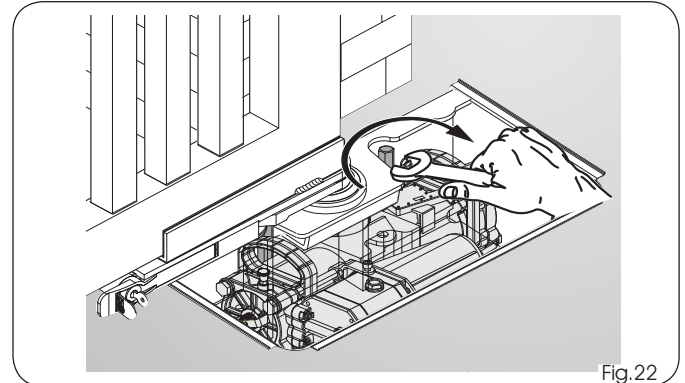

Fig.22

15) Close the gate and secure it to the mechanical release.

16) Open and close the gate, checking the respective limit switches, as described in chapter 5, and adjust them if necessary.

17) Hydraulically lock the operator according to the instructions in chapter 7.1.

18) Perform the electrical connections, as described in the instructions of the electronic equipment, paying attention to the polarity of the encoder.

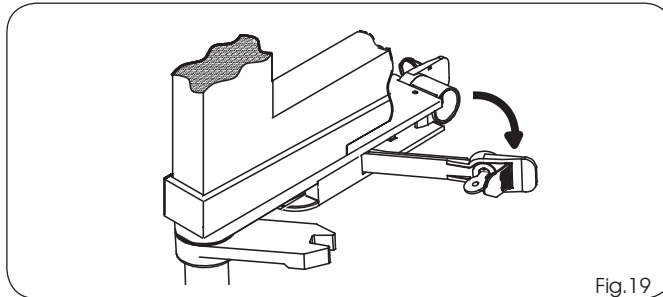

Fig.19

11) Ring the released gate to the open position, checking that the release part freed from the gate **remains at the closed position as in figure 20 ref.①**.

5 INTERNAL MECHANICAL LIMIT SWITCHES (POSITIVE STOP)

The S800H ENC operator is supplied, as per standard, with internal opening and closing mechanical limit switches. This facilitates installation as you do not need to make mechanical stops.

The mechanical limit switches (POSITIVE STOP) can be adjusted in the last 30° of the operator's MAXIMUM stroke, opening and closing.

FAAC SUPPLIES THE LIMIT SWITCHES FULLY OPEN (MAXIMUM PINION ROTATION ANGLE).

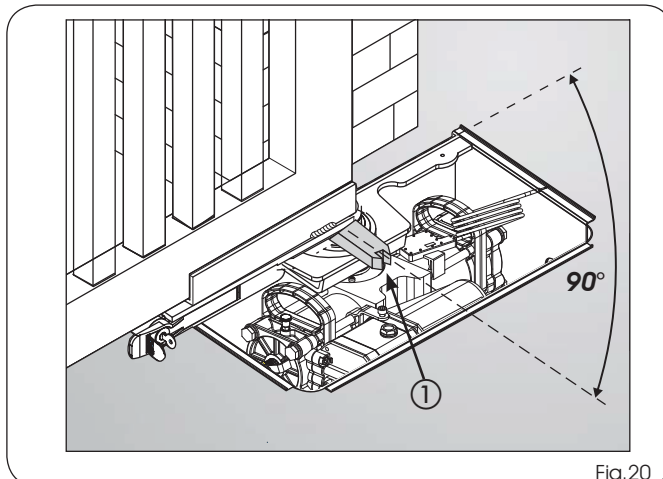

Fig.20

5.1 LIMIT SWITCH ADJUSTMENT

- 1) Release the operator hydraulically. (See chap.7.1)
- 2) Close the leaf, bringing it to the closing position by hand
- 3) Unscrew the cap (Fig.23 ref. A-B) of the closing limit switch screw (Fig.23 ref.①).
- 4) UNSCREW the closing limit switch screw (Fig.23 ref.①), until the leaf appears to be moving.
- 5) Screw the cap (Fig.23 ref. A) of the limit switch screw back on.
- 6) Open the leaf, bringing it to the opening position by hand.
- 7) Unscrew the cap (Fig.23 ref. A-B) of the opening limit switch screw (Fig.23 ref.②).
- 8) UNSCREW the opening limit switch screw (Fig.23 ref.②), until the leaf appears to be moving.
- 9) Screw the cap of the limit switch screw back on.
- 10) Open and close the gate to make sure that the limit switches are adjusted correctly.
- 11) Lock the operator, following the instructions in chapter 7.1.

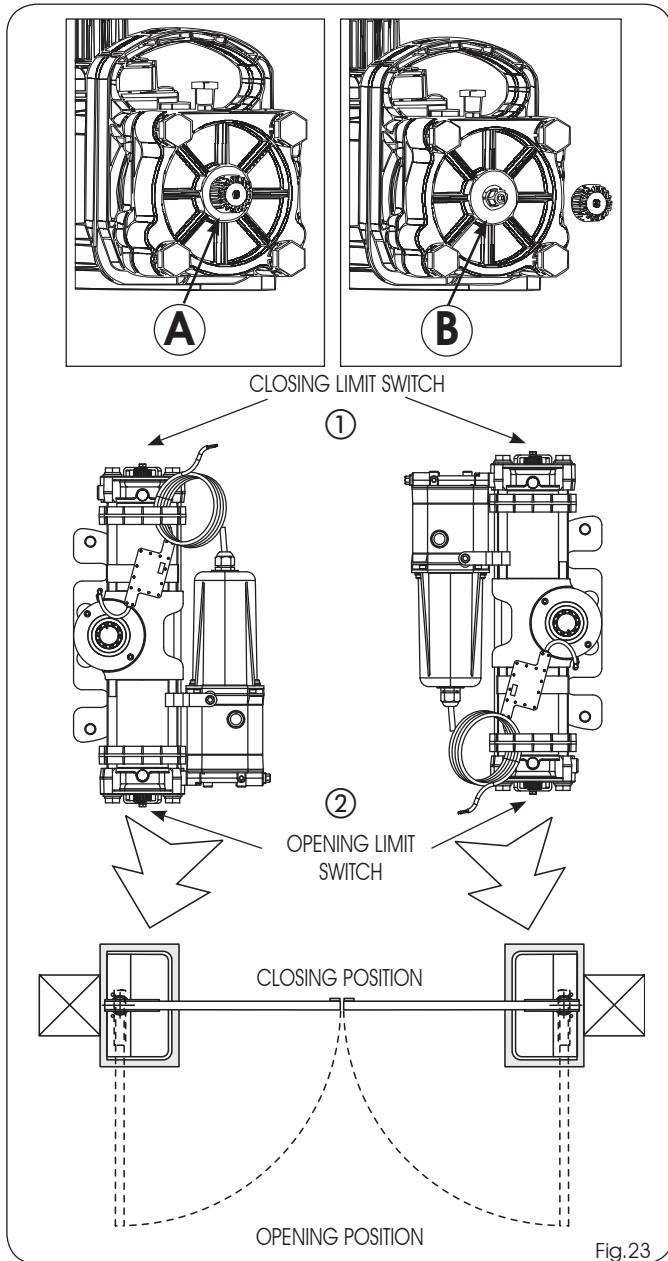

Fig.23

6 FINAL OPERATIONS

⚠ To avoid excessive voltage drops, the engine cables should have a cross-section of 2.5 mm, and be no longer than 20 m. The overall extension of the BUS line cables must not exceed 100 m (all the accessory BUS connection cables included)

- 1) Connect the engine (Fig.1 ref. ⑧) and the encoder (Fig.1 ref. ⑨) to the electronic equipment according to the instructions.
- 2) Secure the cover of the support box with the supplied screws (Fig.24;25).
- 3) Where foreseen by standards in force, apply at least two "automatic movement hazard" signs on both sides of the automation.

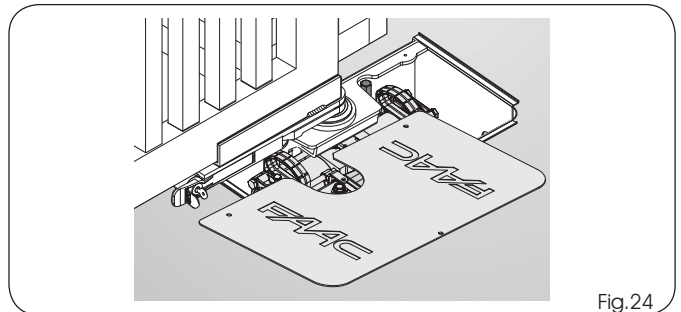

Fig.24

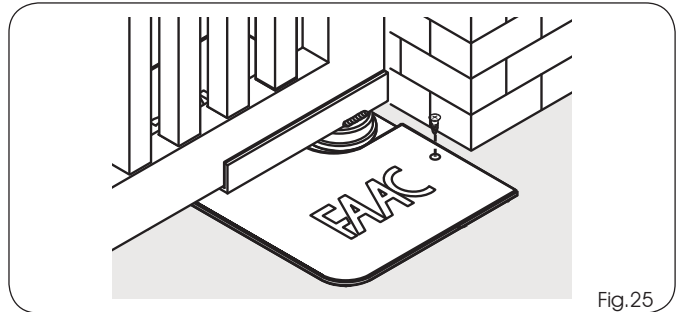

Fig.25

7 MANUAL OPERATION

⚠ Before performing the release and lock operations, make sure power has been disconnected to the operator and that it is not in movement.

7.1 HYDRAULIC RELEASE OF THE OPERATOR

If you need to move the gate by hand due to a power failure or a malfunction in the automation, act on the hydraulic release device by means of the specific lever (Fig.1 ref.⑥) or release key (Fig.1 ref.⑧):

- 1) Remove the cover from the support box.
- 2) Act on the release screw (Fig.26 ref.①), (if there is no lever, insert the hexagonal recess of the supplied key (Fig.26 ref.②)):
 - To **RELEASE**, turn the screw one turn anticlockwise (to keep oil from escaping)
 - To **RELOCK**, turn the screw clockwise to the mechanical stop (without forcing it).

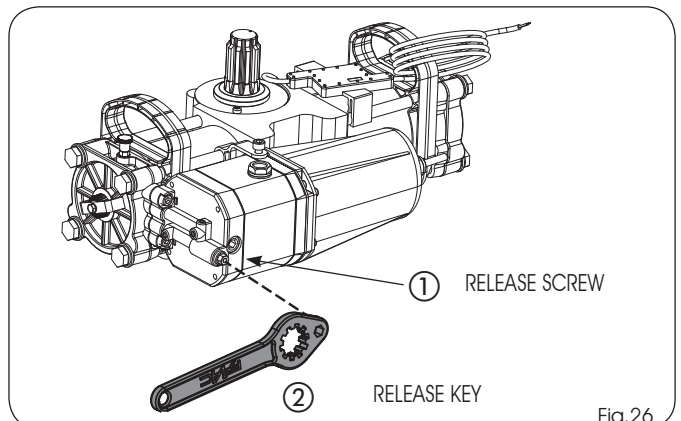

Fig.26

7.2 EMERGENCY MECHANICAL RELEASE (OPTIONAL)

The S800H ENC operator has an optional manual emergency mechanical release.

If you need to move the gate by hand due to a power failure or a malfunction in the automation, act on the key-operated release device.

The device is installed on the support bracket of the gate (Fig.27 ref. ①) and makes it possible to release the system both from inside and outside the property. **NO BUSHES OTHER THAN THOSE SUPPLIED ARE NECESSARY.**

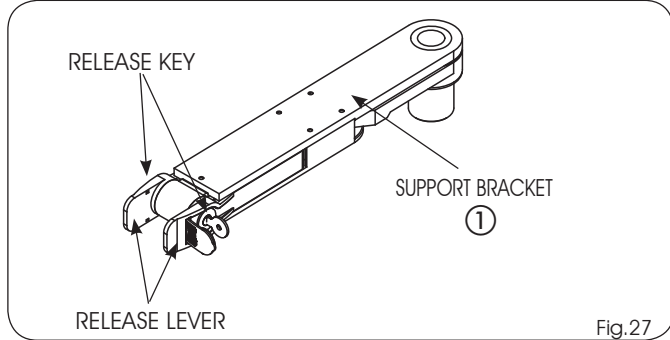

Proceed as follows to move the leaf by hand:

- 1) Open the protective cover (Fig.28 ref. ②).
- 2) Insert the release key in the lock (Fig.28 ref. ③) and turn it clockwise to the stop.
- 3) Pull the release lever towards you (Fig.28 ref. ①).
- 4) Move the leaf by hand.

Proceed as follows to restore the system to normal operation:

- 1) Put the release lever back to its home position (Fig.27).
- 2) Insert the release key in the lock (Fig.28 ref. ③) and turn it anticlockwise to the stop and remove it.
- 3) Close the protective cap of the lock.
- 4) Move the leaf by hand until it hooks the locking bracket.

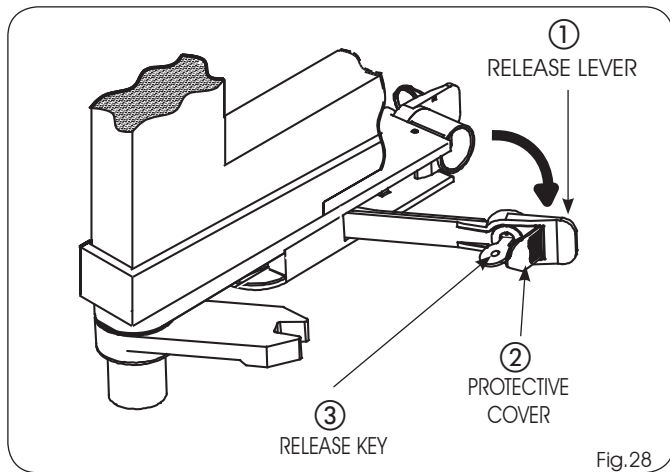

8 MAINTENANCE

Perform a functional check of the system at least every six months, paying special attention to the efficiency of the safety and release devices (including the operator's thrust force) and to perfect functioning of the gate hinges.

The safety devices installed in the system must be checked every six months.

8.1 BLEED OPERATIONS

The S800H ENC operator is supplied with the hydraulic circuit without air. It does not need to be bled. It is only necessary when performing maintenance on the hydraulic system or when topping up the oil level.

The presence of air in the hydraulic circuit causes the automation to malfunction. This can be seen when the leaf moves abnormally and makes too much noise while operating.

Proceed as follows to solve the problem:

- 1) Command the gate to open.
- 2) While the leaf is moving, loosen the opening bleed screw (Fig.29 ref.①).
- 3) Allow air to exit the hydraulic circuit through the bleed screw until non-emulsified oil seeps out.
- 4) Tighten the bleed screw before the operator finishes the opening cycle.
- 5) Command the gate to close.
- 6) While the leaf is moving, loosen the closing bleed screw (Fig.29 ref.②).
- 7) Allow air to exit the hydraulic circuit through the bleed screw until non-emulsified oil seeps out.
- 8) Tighten the bleed screw before the operator finishes the closing cycle.
- 9) Repeat these operations several times.
- 10) Restore the oil level so that it is just below the filler cap (Fig. 30 ref.①).

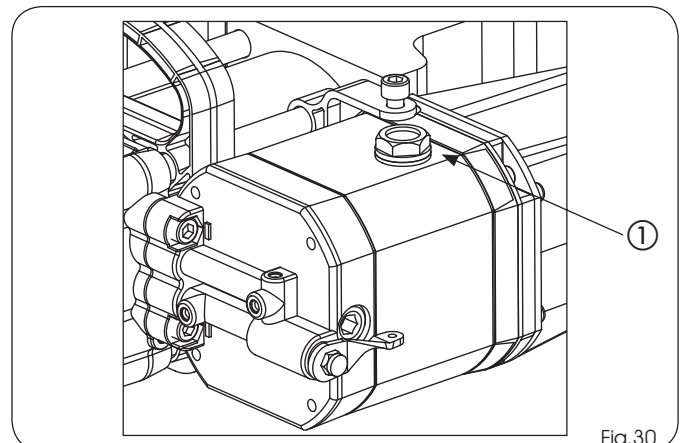
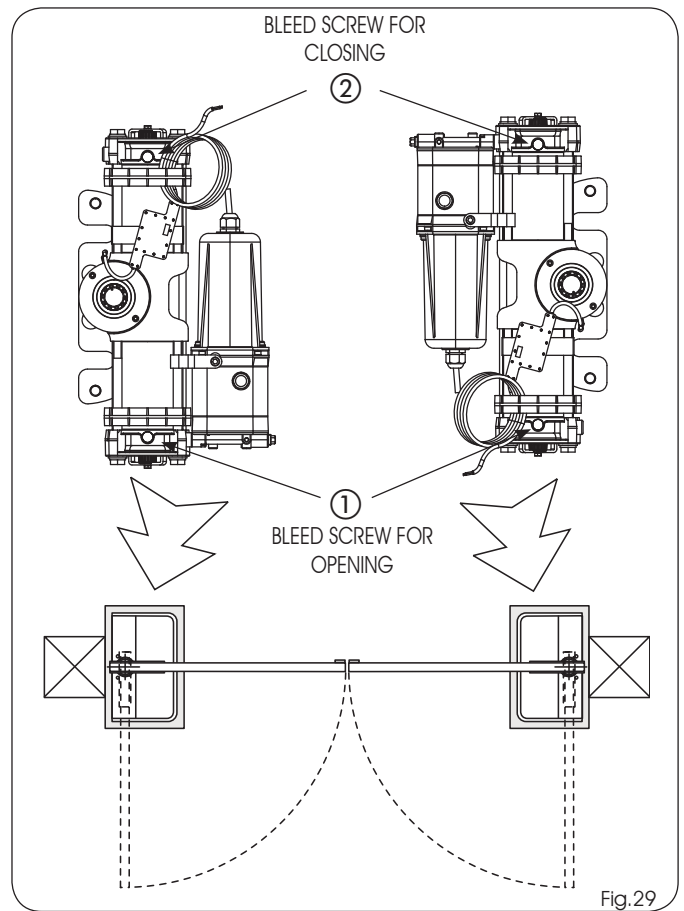

SEDE - HEADQUARTERS

FAAC S.p.A.

Via Calari, 10
40069 Zola Predosa (BO) - ITALY
Tel. +39 051 61724 - Fax +39 051 758518
www.faac.it - www.faacgroup.com

ASSISTENZA IN ITALIA

SEDE

tel. +39 051 6172501
www.faac.it/ita/assistenza

FIRENZE

tel. +39 055 301194
filiale.firenze@faacgroup.com

MILANO

tel +39 02 66011163
filiale.milano@faacgroup.com

PADOVA

tel +39 049 8700541
filiale.padova@faacgroup.com

ROMA

tel +39 06 41206137
filiale.roma@faacgroup.com

TORINO

tel +39 011 6813997
filiale.torino@faacgroup.com

SUBSIDIARIES

AUSTRIA

FAAC GMBH
Salzburg - Austria
tel. +43 662 8533950
www.faac.at

FAAC TUBULAR MOTORS
tel. +49 30 56796645
faactm.info@faacgroup.com
www.faac.at

AUSTRALIA

FAAC AUSTRALIA PTY LTD
Homebush, Sydney - Australia
tel. +61 2 87565644
www.faac.com.au

BENELUX

FAAC BENELUX NV/SA
Brugge - Belgium
tel. +32 50 320202
www.faacbenelux.com

FAAC TUBULAR MOTORS
tel. +31 475 406014
faactm.info@faacgroup.com
www.faacbenelux.com

CHINA

FAAC SHANGHAI
Shanghai - China
tel. +86 21 68182970
www.faacgroup.cn

FRANCE

FAAC FRANCE
Saint Priest, Lyon - France
tel. +33 4 72218700
www.faac.fr

FAAC FRANCE - AGENCE PARIS
Massy, Paris - France
tel. +33 1 69191620
www.faac.fr

FAAC FRANCE - DEPARTEMENT
VOLETS
Saint Denis de Pile - Bordeaux - France
tel. +33 5 57551890
www.faac.fr

GERMANY

FAAC GMBH
Freilassing - Germany
tel. +49 8654 49810
www.faac.de

FAAC TUBULAR MOTORS
tel. +49 30 5679 6645
faactm.info@faacgroup.com
www.faac.de

INDIA

FAAC INDIA PVT. LTD
Noida, Delhi - India
tel. +91 120 3934100/4199
www.faacindia.com

IRELAND

NATIONAL AUTOMATION LIMITED
Boyle, Co. Roscommon - Ireland
tel. +353 071 9663893
www.faac.ie

MIDDLE EAST

FAAC MIDDLE EAST FZE
Dubai Silicon Oasis free zone
tel. +971 4 372 4187
www.faac.ae

NORDIC REGIONS

FAAC NORDIC AB
Perstorp - Sweden
tel. +46 435 779500
www.faac.se

POLAND

FAAC POLSKA SP.ZO.O
Warszawa - Poland
tel. +48 22 8141422
www.faac.pl

RUSSIA

FAAC RUSSIA LLC
Moscow - Russia
tel. +7 495 646 24 29
www.faac.ru

SPAIN

CLEM, S.A.U.
S. S. de los Reyes, Madrid - Spain
tel. +34 091 358 1110
www.faac.es

SWITZERLAND

FAAC AG
Altdorf - Switzerland
tel. +41 41 8713440
www.faac.ch

TURKEY

FAAC OTOMATİK GEÇİŞ SİSTEMLERİ
SAN. VE TİC. LTD. ŞTİ.
Çağlayan, Kağıthane, İstanbul - Turkey
tel. +90 (0)212 - 3431311
www.faac.com.tr

UNITED KINGDOM

FAAC UK LTD.
Basingstoke, Hampshire - UK
tel. +44 1256 318100
www.faac.co.uk

U.S.A.

FAAC INTERNATIONAL INC
Rockledge, Florida - U.S.A.
tel. +1 904 4488952
www.faacusa.com

FAAC INTERNATIONAL INC
Fullerton, California - U.S.A.
tel. +1 714 446 9800
www.faacusa.com