

BLIZZARD 500 C

BLIZZARD 900 C

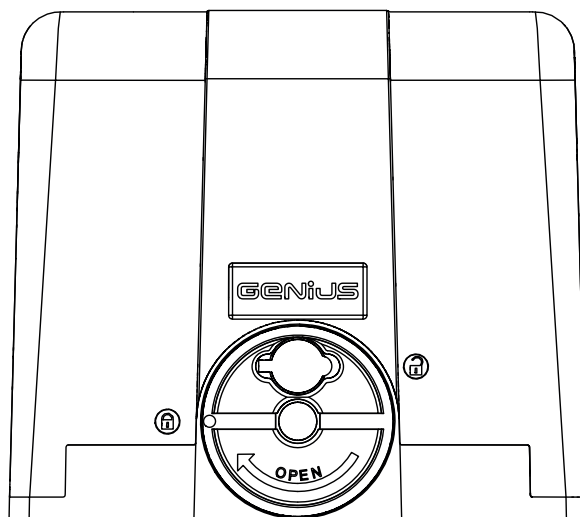

GENIUS[®]

© Copyright FAAC S.p.A. dal 2016. Tutti i diritti riservati.

Nessuna parte di questo manuale può essere riprodotta, archiviata, distribuita a terzi né altrimenti copiata, in qualsiasi formato e con qualsiasi mezzo, sia esso elettronico, meccanico o tramite fotocopia, senza il preventivo consenso scritto di FAAC S.p.A.

Tutti i nomi e i marchi citati sono di proprietà dei rispettivi fabbricanti.

I clienti possono effettuare copie per esclusivo utilizzo proprio.

Questo manuale è stato pubblicato nel 2016.

© Copyright FAAC S.p.A. from 2016. All rights reserved.

No part of this manual may be reproduced, archived, distributed to third parties nor copied in any other way, in any format and with any means, be it electronic, mechanical or by photocopying, without prior written authorisation by FAAC S.p.A.

All names and trademarks mentioned are the property of their respective manufacturers.

Customers may make copies exclusively for their own use.

This manual was published in 2016.

© Copyright FAAC S.p.A. depuis 2016. Tous droits réservés.

Aucune partie de ce manuel ne peut être reproduite, archivée ou distribuée à des tiers ni copiée, sous tout format et avec tout moyen, qu'il soit électronique, mécanique ou par photocopie, sans le consentement écrit préalable de FAAC S.p.A.

Tous les noms et les marques cités sont la propriété de leurs fabricants respectifs.

Les clients peuvent faire des copies pour leur usage exclusif.

Ce manuel a été publié en 2016.

© Copyright FAAC S.p.A. del 2016. Todos los derechos están reservados.

No puede reproducirse, archivar, distribuirse a terceros ni copiarse de ningún modo, ninguna parte de este manual, con medios mecánicos o mediante fotocopia, sin el permiso previo por escrito de FAAC S.p.A.

Todos los nombres y las marcas citadas son de propiedad de los respectivos fabricantes.

Los clientes pueden realizar copias para su uso exclusivo.

Este manual se ha publicado en 2016.

© Copyright FAAC S.p.A. van 2016. Alle rechten voorbehouden.

Niets uit deze handleiding mag gereproduceerd, gearchiveerd, aan derden openbaar gemaakt of op andere wijze gekopieerd worden, in om het even welke vorm en met geen enkel middel, noch elektronisch, mechanisch of via fotokopiëren, zonder schriftelijke toestemming vooraf van FAAC S.p.A.

Alle vermelde namen en merken zijn eigendom van de respectievelijke fabrikanten.

De klanten mogen kopieën maken die enkel voor eigen gebruik bestemd zijn.

De handleiding werd in 2016 gepubliceerd.

© Copyright FAAC S.p.A. 2016. Tüm hakları saklıdır.

Bu kılavuzunun hiç bir bölümünün, FAAC S.p.A. tarafından yazılı izin olmadan yeniden üretilmesi, arşivlenmesi, üçüncü şahıslara dağıtılması ve de hiç bir formatta ve hiç bir şekilde, elektronik, mekanik veya fotokopi yöntemiyle çoğaltılması yasaktır.

Belirtilen tüm isimler ve markalar üreticinin mülkiyetindedir.

Müşteriler sadece kendi kullarımları için kopyalama işlemi yapabilirler.

Bu kılavuz 2015 yılında yayınlanmıştır.

CONTENTS

1. INTRODUCTION TO THIS INSTRUCTION MANUAL	4
1.1 Meaning of Symbols Used.....	4
2. SAFETY RECOMMENDATIONS	5
2.1 Installer safety.....	5
2.2 Transport and storage.....	5
2.3 Unpacking and handling.....	6
2.4 Disposal of the product.....	6
3. BLIZZARD 500-900 C	6
3.1 Intended use.....	6
3.2 Limitations of use.....	6
3.3 Prohibited uses.....	6
3.4 Emergency Use.....	7
3.5 Product Warnings.....	7
3.6 Product Identification.....	7
3.7 Technical Characteristics.....	7
3.8 Component Identification.....	8
3.9 Dimensions.....	8
4. INSTALLATION REQUIREMENTS	9
4.1 Mechanical Requirements.....	9
4.2 Electrical System.....	9
4.3 Example System.....	10
5. INSTALLATION	10
5.1 Tools Required.....	10
5.2 Installation Dimensions.....	11
5.3 Base plate.....	12
5.4 Fastening the Gear Motor.....	12
5.5 Manual Operation.....	13
5.6 Installing the Rack.....	13
5.7 Adjustments and Checks.....	16
6. ELECTRONIC BOARD	17
6.1 Terminal boards and connectors.....	18
6.2 Photocells and safety devices.....	19
7. START-UP	20
7.1 Power supply and earthing.....	20
7.2 LEDs Check.....	20
7.3 Installation of the Limit Switches.....	21
7.4 Programming.....	22
7.5 Direction of movement check.....	24
7.6 Final Operations.....	24
8. MAINTENANCE	25
8.1 Scheduled Maintenance.....	25
9. OPERATING LOGICS	27
10. INSTRUCTIONS FOR USE	30
10.1 Safety recommendations.....	30
10.2 Product Warnings.....	30
10.3 Emergency Use.....	30
10.4 Manual Operation.....	30

EU DECLARATION OF CONFORMITY

The Manufacturer

Company name: FAAC S.p.A. Soc. Unipersonale

Address: Via Calari, 10 - 40069 Zola Predosa BOLOGNA - ITALY

hereby declares under his sole responsibility that the following product:

Description: Gear motor for sliding gates

Model: BLIZZARD 500 C; BLIZZARD 900 C.

Complies with the following relevant Union harmonization legislations:

2014/30/EU

2011/65/EU

Furthermore, the following harmonised standards have been applied:

EN61000-6-2:2005

EN61000-6-3:2007 + A1:2011

Bologna, Italy, 06-02-2017 CEO

DECLARATION OF INCORPORATION FOR PARTLY COMPLETED MACHINERY

(2006/42/EC ANNEX II P.1, B)

Manufacturer and person authorised to draft the applicable technical documentation

Company name: FAAC S.p.A. Soc. Unipersonale

Address: Via Calari, 10 - 40069 Zola Predosa BOLOGNA - ITALY

Hereby declares that the partly completed machinery:

Description: Gear motor for sliding gates

Model: BLIZZARD 500 C; BLIZZARD 900 C.

the following essential requirements of the Machinery Directive 2006/42/EC (including all applicable amendments) have been applied and fulfilled:

1.1.2, 1.1.3, 1.1.5, 1.1.6, 1.2.1, 1.2.3, 1.2.5, 1.2.6, 1.3.1, 1.3.2, 1.3.4, 1.3.6, 1.3.9, 1.4.1, 1.4.2.1, 1.5.1, 1.5.2, 1.5.5, 1.5.6, 1.5.7, 1.5.8, 1.5.10, 1.5.11, 1.6.1, 1.6.4, 1.7.1, 1.7.2, 1.7.3, 1.7.4.2, 1.7.4.3

and that the relevant technical documentation has been compiled in compliance with part B of Annex VII.

Furthermore, the following harmonised standards have been applied:

EN12100:2010

EN13849-1:2015

EN13849-2:2012

Other applied standards:

EN12453:2000

Undertakes to transmit by mail or by e-mail, in response to a reasoned request by the national authorities, relevant information on the partly completed machinery.

It is also declared that the partly completed machinery identified above may not be commissioned until the final machine - into which it will be incorporated - has been declared compliant with the provisions of the above mentioned Machine Directive 2006/42/EC.

Bologna, Italy, 06-02-2017 CEO

1. INTRODUCTION TO THIS INSTRUCTION MANUAL

This manual provides the correct procedures and requirements for installing BLIZZARD 500-900 C and maintaining it in a safe condition. When drafting the manual, the results of the risk assessment conducted by FAAC S.p.A. on the entire product life cycle have been taken into account in order to implement effective risk reduction measures. The following stages of the life cycle of the product have been considered:

- Delivery/handling
- Assembly and installation
- Set-up and commissioning
- Operation
- Maintenance/troubleshooting
- Disposal at the end of the product's life cycle

Risks arising from installation and using the product have been taken into consideration; these include:

- Risks for the installation/maintenance technician (technical personnel)
- Risks for the user of the automation system
- Risks to product integrity (damage)

In Europe, the automation of a gate falls under the Machinery Directive 2006/42/EC and the corresponding harmonised standards. Anyone automating a gate (new or existing) is classified as the Manufacturer of the Machine. They are therefore required by law, among other things, to carry out a risk analysis of the machine (automatic gate in its entirety) and take protective measures to fulfil the essential safety requirements specified in Annex I of the Machinery Directive.

FAAC S.p.A. recommends that you always comply with standards EN 12453 and EN 12445 and in particular that you adopt the safety criteria and devices indicated in these standards, without exception, including the dead-man function.

This manual also contains general information and guidelines, which are purely illustrative and not exhaustive, in order to facilitate the activities carried out by the Manufacturer of the Machine in all respects with regard to carrying out the risk analysis and drafting the instructions for use and maintenance of the machine. It should be clearly understood that FAAC S.p.A. accepts no liability for the reliability and/ or completeness of the above instructions. As such, the manufacturer of the machine must carry out all the activities required by the Machinery Directive and the corresponding harmonised standards on the basis of the actual condition of the locations and structures where the product BLIZZARD 500-900 C will be installed, prior to commissioning the machine. These activities include the analysis of all the risks associated with the machine and subsequent implementation of all safety measures intended to fulfil the essential safety requirements.

This manual contains references to European standards. The automation of a gate must fully comply with any laws, standards and regulations applicable in the country where installation will take place.

 Unless otherwise specified, the measurements provided in the instructions are in mm.

1.1 MEANING OF SYMBOLS USED



 **1** Symbols: notes and warnings on the instructions



 **WARNING ELECTRIC SHOCK HAZARD** - The operation or stage described must be performed following the supplied instructions and applicable safety regulations.

 **WARNING, PERSONAL INJURY HAZARD OR RISK OF DAMAGE TO COMPONENTS** - The operation or stage described must be performed following the supplied instructions and applicable safety regulations.

 **WARNING** - Details and specifications which must be respected in order to ensure that the system operates correctly.

 **RECYCLING AND DISPOSAL** - The materials used in manufacturing, the batteries and any electronic components must not be sent to landfill. They must be taken to authorised recycling and disposal centres.

 **FIGURE** E.g.:  1-3 see Figure 1 - detail 3.

 **TABLE** E.g.:  1 see Table 1.

 **CHAPTER/SECTION** E.g.: §1.1 see section 1.1.

 **2** Symbols: safety indications (ISO 7010)

 **GENERAL HAZARD**
Personal injury hazard or risk of damage to components.

 **ELECTRIC SHOCK HAZARD**
Risk of electric shock from live parts.

 **CRUSHING HAZARD, DANGER TO THE MUSCULOSKELETAL SYSTEM**
Risk of musculoskeletal crushing - Personal injury hazard when manually lifting heavy loads.

 **BURN HAZARD**
Risk of burns due to the presence of high-temperature parts.

 **CRUSHING HAZARD**
Risk of crushing to the hands/feet due to the presence of heavy parts.

 **CRUSHING HAZARD**
Risk of crushing to the hands/feet due to the presence of heavy parts.

 **CUTTING/AMPUTATION/PUNCTURE HAZARD**
Cutting hazard due to the presence of sharp components or the use of pointed/sharp tools (drill).

 **CUTTING/AMPUTATION/PUNCTURE HAZARD**
Cutting hazard due to the presence of sharp components or the use of pointed/sharp tools (drill).

 **SHEARING HAZARD**
Risk of shearing from moving parts.

 **IMPACT/CRUSHING HAZARD**
Risk of impact or crushing due to moving parts.

 **FORKLIFT TRUCK IMPACT HAZARD**
Risk of collision/impact with forklift trucks.

 **3** Symbols: personal protective equipment

Personal protective equipment must be worn to protect against hazards (e.g. crushing, cutting, shearing etc.):

 Obligatory use of mask/goggles to protect the eyes from the risk of shards produced when using drills or welding equipment.

 Obligatory use of work gloves.

 Obligatory use of safety footwear.

2. SAFETY RECOMMENDATIONS

This product is placed onto the market as “partly completed machinery”, therefore it cannot be commissioned until the machine in which it will be incorporated has been identified and declared to conform to the Machinery Directive 2006/42/EC by the actual Manufacturer.

 Incorrect installation and/or incorrect use of the product might cause serious harm to people. Read and comply with all the instructions before starting any activity on the product. Keep these instructions for future reference.

Perform installation and other activities adhering to the sequences provided in the instructions manual.

Always comply with all the requirements contained in the instructions and warning tables at the beginning of the paragraphs. Always comply with the safety recommendations.

Only the installer and/or maintenance technician is authorised to work on the automation components. Do not modify the original components in any way.

Close off the work site (even temporarily) and prevent access/transit. EC countries must comply with the legislation that transposes the European Construction Site Directive 92/57/EC.

The installer is responsible for the installation/testing of the automation and for completing the Register of the system.

The installer must prove or declare to possess technical and professional proficiency to perform installation, testing and maintenance activities according to the requirements in these instructions.

2.1 INSTALLER SAFETY

Installation activities require special work conditions to reduce to the minimum the risks of accidents and serious damage. Furthermore, the suitable precautions must be taken to prevent risks of injury to persons or damage.

 The installer must be in good physical and mental condition, aware of and responsible for the hazards that may be generated when using the product.

The work area must be kept tidy and must not be left unattended.

Do not wear clothes or accessories (scarves, bracelets, etc.) that may get caught in moving parts.

Always wear the personal protective equipment recommended for the type of activity to be carried out.

The required level of workplace lighting must be equal to at least 200 lux.

Operate CE marked machinery and equipment in compliance with the manufacturer's instructions. Use work instruments in good conditions.

Use the transport and lifting equipment recommended in the instructions manual.

Use safety-compliant portable ladders of adequate size, fitted with anti-slip devices at the top and bottom, equipped with retainer hooks.

2.2 TRANSPORT AND STORAGE

 4 Symbols: warnings on packaging.



Read the instructions.



Handle with care. Fragile parts.



Up indication.



Keep away from water and moisture.



Maximum number of stacked packages.



CE marking.

SUPPLY ON PALLETS

RISKS



PERSONAL PROTECTIVE EQUIPMENT

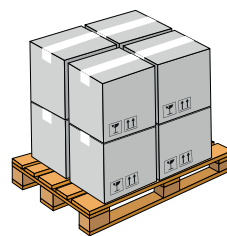
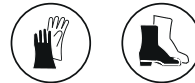

Follow the instructions on the packaging during handling.
Use a forklift or pallet truck, following safety regulations to avoid the risk of impacts or collisions.

SINGLE PACKAGE

RISKS



PERSONAL PROTECTIVE EQUIPMENT

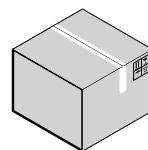

Follow the instructions on the packaging during handling.

STORAGE

Store the product in its original packaging, in closed and dry premises, protected from the sun and free from dust and aggressive substances. Protect from mechanical stress. If stored for more than 3 months, regularly check the condition of the components and the packaging.

- Storage temperature: 5°C to 30°C.
- Percentage of humidity: 30% to 70%.

2.3 UNPACKING AND HANDLING

RISKS



PERSONAL PROTECTIVE EQUIPMENT



1. Open the package.

i The gear motor casing is not fixed.

2. Remove the magnetic limit switches and the bag of accessories.

3. Remove the casing.

! Do not lift the gear motor by the electronic board.

4. Lift the gear motor, holding it by the base.

i Check that all components are present and intact 2.

5. Dispose of the packaging materials.

3. BLIZZARD 500-900 C

3.1 INTENDED USE

GENIUS BLIZZARD 500-900 C series gear motors are designed to operate horizontal sliding gates for residential use (including in apartment complexes).

One gear motor must be installed for each sliding gate section. The gate must be moved via a rack.

Installations of BLIZZARD 500-900 C must be used for vehicular traffic.

To operate the gate manually, follow the instructions in § 5.5.

! Any other use which is not expressly specified in these instructions is prohibited and could affect the integrity of the product and/or represent a source of danger.

3.2 LIMITATIONS OF USE

The gate must fall within the dimensional and weight limitations indicated in the technical data section. Obey the limitations on frequency of use listed in the technical data section.

Using the product in any configuration other than that provided for by FAAC S.p.A. is prohibited. It is prohibited to modify any product component.

The presence of weather conditions such as snow, ice and strong wind, even when occasional, could compromise correct automation, affect the integrity of the components and represent a potential source of danger.

If a pedestrian access gate is integrated in the sliding gate section, motorised movement must be disabled when the pedestrian gate is not closed.

BLIZZARD 500-900 C is not designed as a security (break-in protection) system.

Implementing automation requires the installation of the necessary safety devices, identified by the installer through an appropriate risk assessment of the installation site.

3.3 PROHIBITED USES

- Uses other than the intended use are prohibited.
- It is prohibited to install the automation system outside of the limits specified in the Technical Data and Installation Requirements sections.
- It is forbidden to use BLIZZARD 500-900 C in a constructional



The packaging materials (plastic, polystyrene etc.) must not be left within reach of children, as they are potential hazards.

When you have finished with them, dispose of the packaging in the appropriate containers, as per applicable waste disposal regulations.

2.4 DISPOSAL OF THE PRODUCT

After dismantling the product, dispose of it in compliance with Standards in force.



The constructive components and materials, batteries and electronic components must not be disposed of with household waste but delivered to authorised disposal and recycling facilities.

configuration other than the one provided for in GENIUS.

- No component part of the product may be modified.
- It is prohibited to install the automation system on escape routes.
- It is prohibited to install the automation system to create fire doors.
- It is prohibited to install the automation system in environments in which there is a risk of explosion and/or fire: the presence of flammable gases or fumes is a serious safety hazard (the product is not 94/9/EG ATEX certified).
- It is prohibited to power the system with energy sources other than those specified.
- It is prohibited to integrate commercial systems and/or equipment other than those specified, or use them for purposes not intended and authorised by their respective manufacturers.
- Do not allow water jets of any type or size to come into direct contact with the gear motor.
- Do not expose the gear motor to corrosive chemicals or atmospheric agents.
- It is prohibited to use and/or install accessories which have not been specifically approved by FAAC S.p.A.
- It is prohibited to use the automation system before performing commissioning.
- It is prohibited to use the automation system in the presence of faults which could compromise safety.
- It is prohibited to use the automation system with the fixed and/or mobile guards removed or altered.
- Do not use the automation system unless the area of operation is free of persons, animals or objects.
- Do not enter/remain in the area of operation of the automation system while it is moving.
- Do not try to prevent the movement of the automation system.
- Do not climb on, hold onto or let yourself be pulled by the leaf. Do not climb onto the gear motor.
- Do not allow children to approach or play in the area of operation of the automation system.
- Do not allow the control devices to be used by anyone who is not specifically authorised and trained to do so.
- Do not allow the control devices to be used by children or persons with mental and physical deficiencies unless they are supervised by an adult who is responsible for their safety.



During manual operation, gently guide the leaf the whole way, do not push it and let it slide freely.

3.4 EMERGENCY USE

In any malfunction, emergency or fault, disconnect the power supply of the automation. If the conditions allow the leaf to be safely moved manually, use the manual operation; otherwise, keep the automation out of service until it is restored/repared.

In case of a fault, the automation must be restored/repared must only be carried out by the installer/maintenance technician.

3.6 PRODUCT IDENTIFICATION

3.5 PRODUCT WARNINGS



Risk of fingers and hands being trapped between the rack, pinion and casing (2).

3.7 TECHNICAL CHARACTERISTICS

The GENIUS BLIZZARD 500 C and BLIZZARD 900 C series gear motors are equipped with an electronic board that controls their automatic operation (§ 6). The travel of the gate is determined by two magnetic limit switches. Movement cannot be reversed: To operate the gate manually, follow the instructions in § 5.5. The board may be equipped with optional accessories:

- obstacle recognition encoder (optional accessory in some models);
- GENIUS 5-pin radio receiver.

5 Technical Data

	BLIZZARD 500 C		BLIZZARD 900 C	
Supply voltage	230 V~ (+6%...-10%) 50 Hz	115 V~ (+6%...-10%) 60 Hz	230 V~ (+6%...-10%) 50 Hz	115 V~ (+6%...-10%) 60 Hz
Electric motor	Asynchronous single phase	Asynchronous single phase	Asynchronous single phase	Asynchronous single phase
Start-up capacitor	10 µF	40 µF	12.5 µF	50 µF
Max power	360 W	350 W	540 W	610 W
Thermal protection	140 °C (automatic rearming)	140 °C (automatic rearming)	140 °C (automatic rearming)	140 °C (automatic rearming)
Max thrust force	390 N	250 N	590 N	540 N
Starting thrust force	300 N	220 N	410 N	380 N
Pinion	Z16 Module 4	Z16 Module 4	Z16 Module 4	Z16 Module 4
Max sliding gate section length	15 m	15 m	15 m	15 m
Max. sliding gate section weight*	500 kg	500 kg	900 kg	900 kg
Sliding gate section speed	12 m/min	14 m/min	12 m/min	14 m/min
Ambient operating temperature	-20 °C - +55 °C	-20 °C - +55 °C	-20 °C - +55 °C	-20 °C - +55 °C
Type of use	Residential/Condominium	Residential/Condominium	Residential/Condominium	Residential/Condominium
Continuous use time (ROT)**	22 min	37 min	23 min	23 min
Ingress Protection	IP44	IP44	IP44	IP44
Dimensions (LxDxH)	297x170x256	297x170x256	297x170x256	297x170x256
Gear motor weight	9.2 kg	9.2 kg	10 kg	10 kg
Electronic board	SPRINT 382	SPRINT 383	SPRINT 382	SPRINT 383

* In the case of a cantilever gate, the maximum weight of the sliding gate section is reduced by 30%

** 20°C, F0=20 (§ 7.4).

3.8 COMPONENT IDENTIFICATION

INSTALLATION ACCESSORIES WHICH ARE NOT SUPPLIED

ENGLISH

Translation of the original instructions

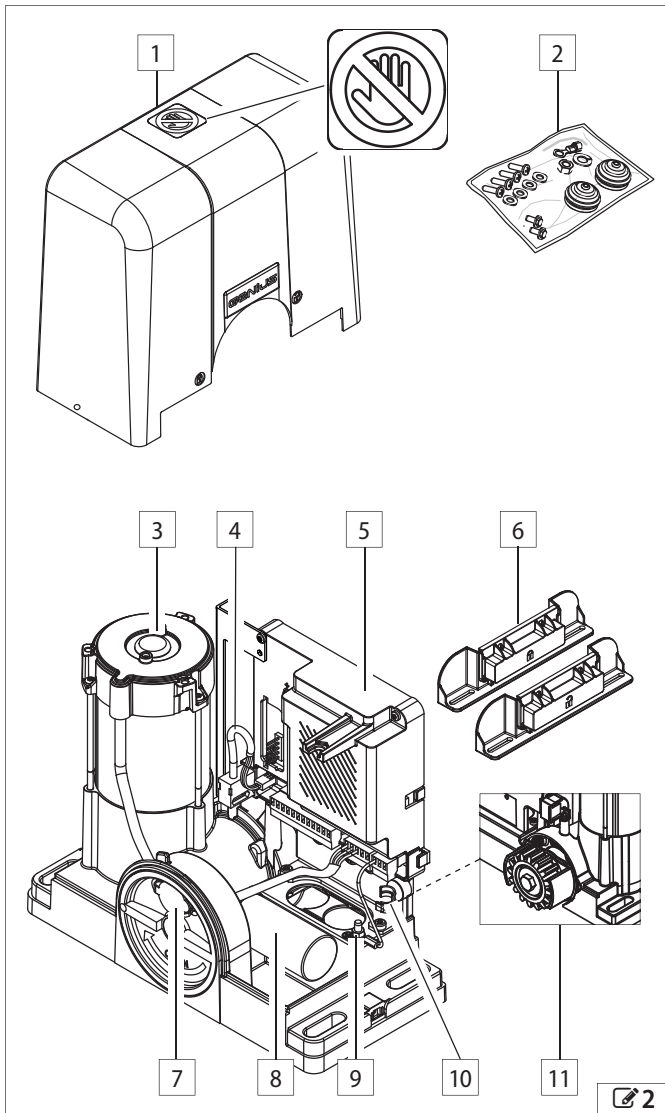

6 Components

- 1 Case and danger symbol
- 2 Hardware/accessories
- 3 Electric motor
- 4 Magnetic limit stop sensor
- 5 Electronic board
- 6 Magnetic limit switches
- 7 Release device
- 8 Start-up capacitor
- 9 Earth connection
- 10 Power cable clamp
- 11 Z16 Module 4 pinion

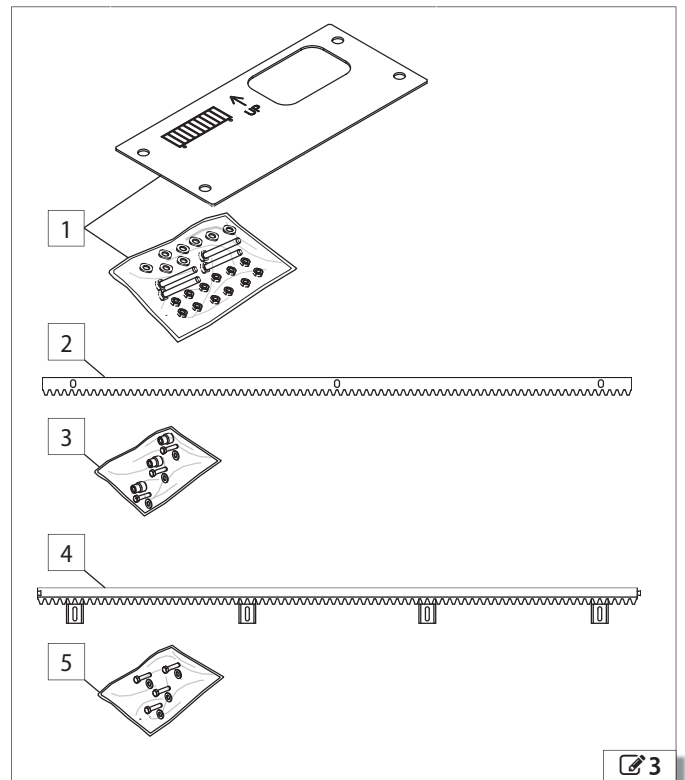

7 Installation Accessories

- 1 Base plate with mounting hardware
- 2 Steel rack
- 3 Spacers for steel rack (to be screwed or welded)
- 4 Nylon rack
- 5 Mounting hardware for nylon rack

3.9 DIMENSIONS

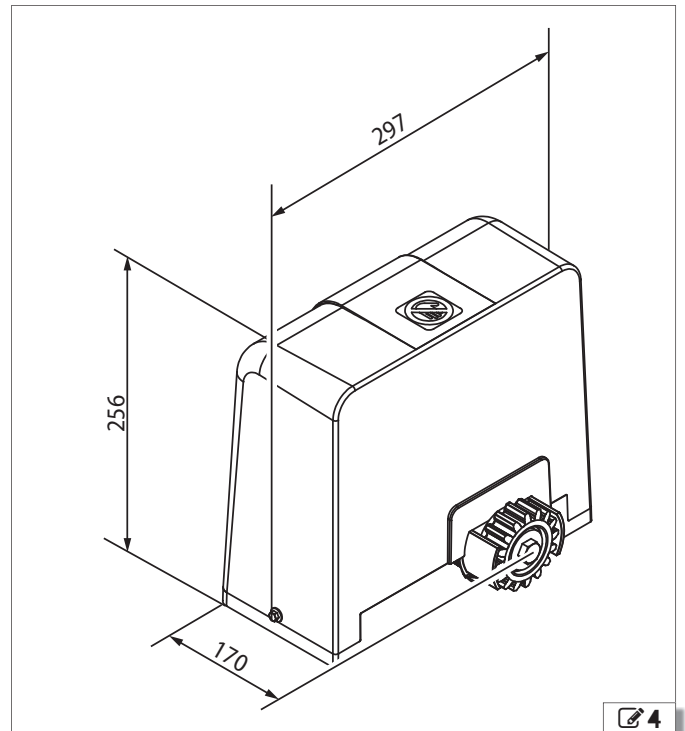

4. INSTALLATION REQUIREMENTS

4.1 MECHANICAL REQUIREMENTS

The mechanical structural components must comply with the requirements of EN 12604 and EN 12605.

Before installing the automation system, the suitability of the mechanical requirements must be established, and the necessary work to reach them performed.

The essential mechanical requirements are as follows:



Solid ground to support the weight of the gate, the structures present and the gear motor. There must be no chance of water accumulating in the installation area. Flat, horizontal paving in the area of movement of the sliding gate section.

Structure (columns, guides, mechanical strikers, sliding gate section) must be solid and there must be no risk of detachment or collapse, taking into consideration the weight of the sliding gate section, force applied by wind and the forces generated by the gear motor. Perform structural calculations where necessary.

No signs of corrosion or cracking in the structure.

Sliding gate section perfectly vertical in all movement positions with regular, uniform movement without friction.

Appropriate devices must be installed to prevent the gate from falling. There must be a lower horizontal sliding guide in good condition; this must be straight, with no deformations, and must be solidly fastened to the ground and free of obstacles along its entire length. The sliding gate section must remain in any position in which it is placed without moving. Presence of guide wheels on the ground, with diameter appropriate for the size and length of the sliding gate section and profile section matching the sliding guide. The number and position of the wheels must ensure adequate and constant distribution of the weight at all times.

Presence of upper containing guide to prevent vertical oscillation of the sliding gate section. The sliding gate section must not under any circumstances come out from its guides and fall. Wheels, rollers and bearings in good condition, lubricated and free from play or friction.

External mechanical limit stops to limit the travel of the sliding gate section when opening and closing. The stops must be suitably sized and solidly fastened so that they resist any impact of the sliding gate section in the event of improper use (gate pushed and left to slide freely). The mechanical limit stops must be positioned at 50 mm beyond the stop position of the sliding gate section, and must ensure that the sliding gate section remains inside its sliding guides.

The thresholds and protrusions of the paving must be appropriately shaped in order to prevent the risk of sliding or slipping.

Safety precaution between the wall (or other fixed element) and the furthest protruding part of the open gate to protect against the risk of persons becoming trapped/crushed. Alternatively, check that the opening force required falls within the maximum permissible limits according to applicable standards and legislation.

Safety devices installed between the fixed and moving parts to prevent against the risk of hands being trapped. Alternatively, apply protective elements preventing the introduction of fingers.

Safety element between the paving and lower edge of the sliding gate section, along its entire path, providing protection from the risk of feet becoming caught in and crushed beneath the wheels. Alternatively, apply protective elements preventing the introduction of feet.

No sharp edges or protruding parts should be present to ensure there is no cutting, hooking or perforation hazard. Alternatively, eliminate or protect any sharp edges and protruding parts.

No slots or openings should be present on the sliding gate section or the fencing to prevent the creation of a shearing hazard. Alternatively, apply protective mesh to any such openings. The mesh should be sufficiently fine to prevent introduction of body parts requiring protection, in relation to the distance between the fixed and moving parts.



For the minimum dimensions to prevent crushing/shearing of body parts, refer to EN 349. For the safety distances required to prevent danger zones being reached, refer to ISO 13857.

There should be a solid surface on the sliding gate section sufficiently large to attach the rack to.

If the area of installation gives rise to the risk of impact by vehicles, provide for an appropriate protective structure to protect the gear motor.

4.2 ELECTRICAL SYSTEM



Always shut off the power supply before performing any work. If the disconnect switch is not in view, apply a warning sign stating "WARNING - Maintenance in Progress".



The electrical system must comply with applicable legislation in the country of installation.

Use components and materials with CE marking which are compliant with the Low Voltage Directive 2014/35/EU and EMC Directive 2014/30/EU.

The power supply line for the automation system must be fitted with a 6 A omnipolar circuit breaker with a contact opening distance of at least 3 mm, with breaking capacity which meets code.

The power supply for the automation system must be fitted with a 30 mA RCD.

The metal parts of the structure must be earthed. Check that the protective earthing system complies with applicable regulations in the country of installation.

The electrical cables of the automation system must be laid in appropriate conduits, which may be rigid or flexible, above or below ground; the size and insulation class must conform with applicable legislation.

Use separate conduits for power supply and low-voltage control cables.

Check buried cable plans to ensure that there are no other electrical cables in proximity to the planned digging/drilling locations to prevent the risk of electrocution.

Check that there are no pipes in the vicinity as well.

It is recommended to install a flashing light in a visible position to warn when the gate is moving.

The control accessories must be positioned in a location which is not hazardous to the user and is also accessible with the gate open. It is advisable to position the control accessories within the field of view of the automation system; this is obligatory when operator presence is required for the controls.

If an emergency stop button has been installed, it must be EN13850 compliant.

The following limits apply with regard to the height from the ground:

- Control accessories = minimum 150 cm

- Emergency button = maximum 120 cm

4.3 EXAMPLE SYSTEM

The example system is a purely illustrative and not exhaustive representation of BLIZZARD 500-900 C.

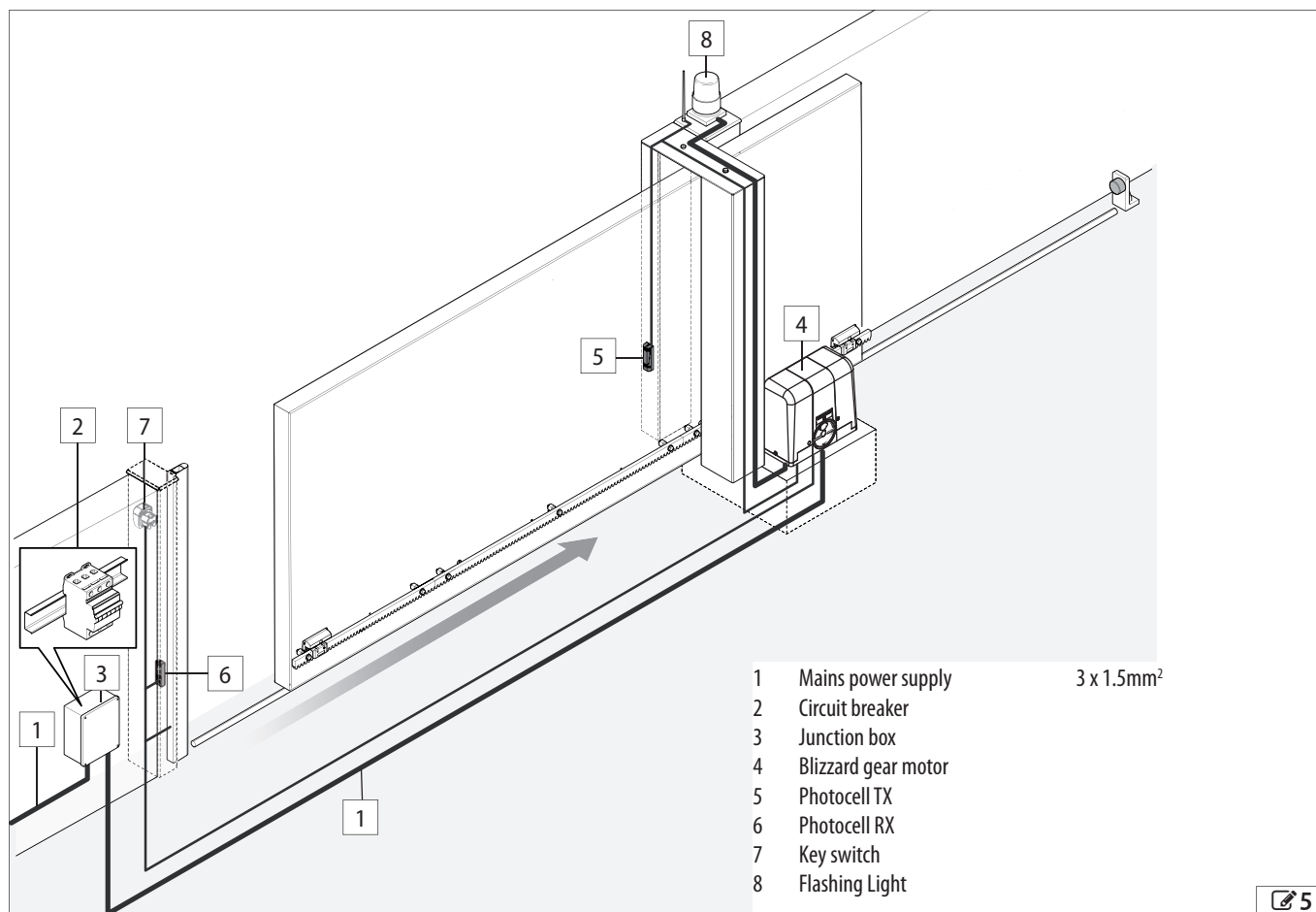

- 1 Mains power supply 3 x 1.5mm²
- 2 Circuit breaker
- 3 Junction box
- 4 Blizzard gear motor
- 5 Photocell TX
- 6 Photocell RX
- 7 Key switch
- 8 Flashing Light



Translation of the original instructions

ENGLISH

5. INSTALLATION

5.1 TOOLS REQUIRED

Use appropriate tools and equipment in working environments which comply with applicable legislation.

8 Symbols: work tools

HEX SPANNER of size indicated
2x17; 13; 10; 8

TORQUE WRENCH - if necessary for safety, a torque wrench and the TIGHTENING TORQUE will be specified E.g. 6 mm hex spanner set to 2.5 Nm

x.x Nm 2.5 Nm
6

ELECTRICIAN'S SCISSORS

HSS DRILL BIT of specified sizes
6.5; 5.5; 3.6

THREAD CUTTER of specified sizes (for steel rack to be screwed on)
M8

SPIRIT LEVEL

- TAPE MEASURE
- SCREW CLAMP
- WELDING EQUIPMENT (for steel rack to be welded on)
- ANGLE GRINDER
- CALLIPER
- WIRE STRIPPER/TERMINAL CRIMPER
- FLAT SCREWDRIVER of the size(s) indicated
2.5
- TORX SCREWDRIVER of the size(s) indicated (electronic board)
T20; T15

5.2 INSTALLATION DIMENSIONS

POSITIONING THE BASE PLATE

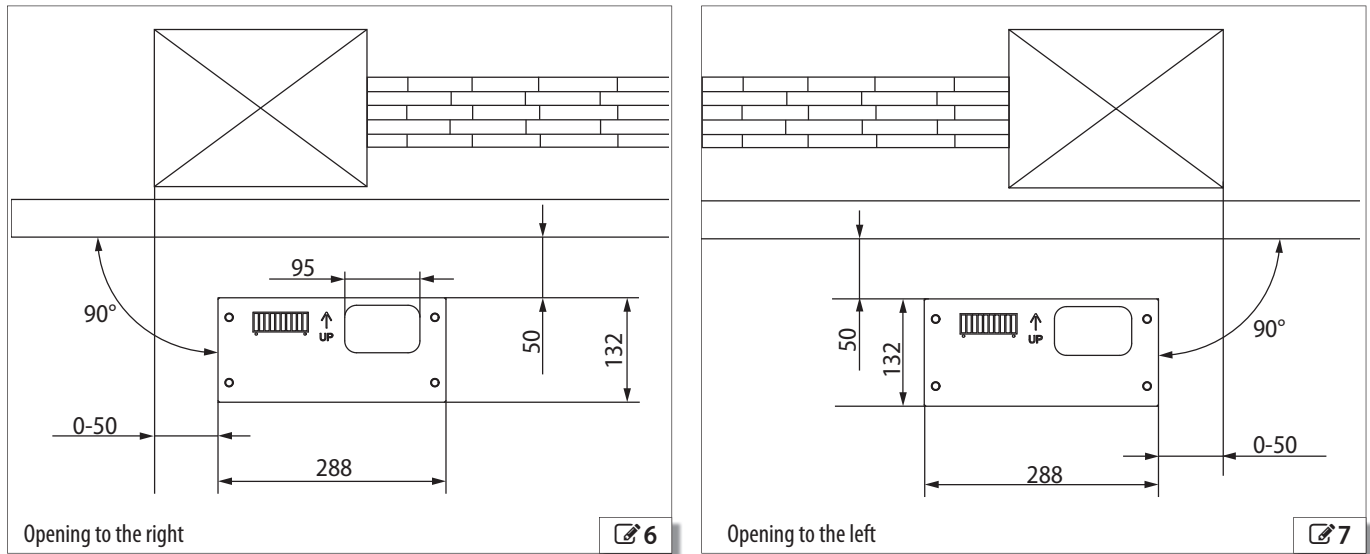

CENTRELINE DISTANCES

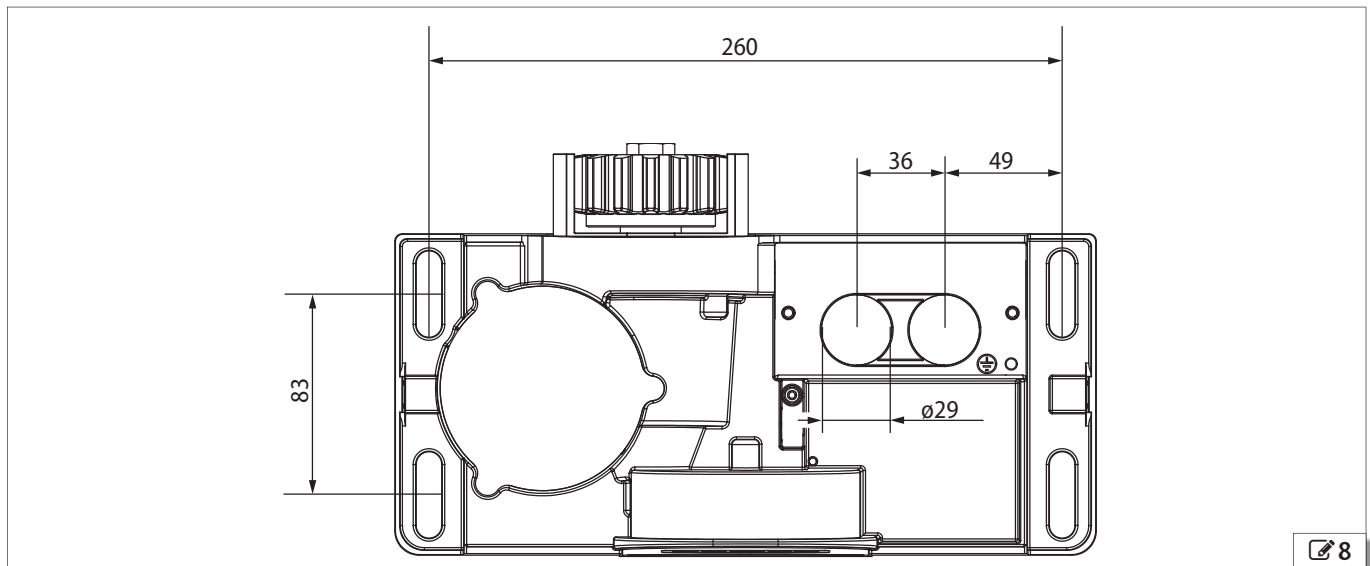

POSITIONING THE RACK

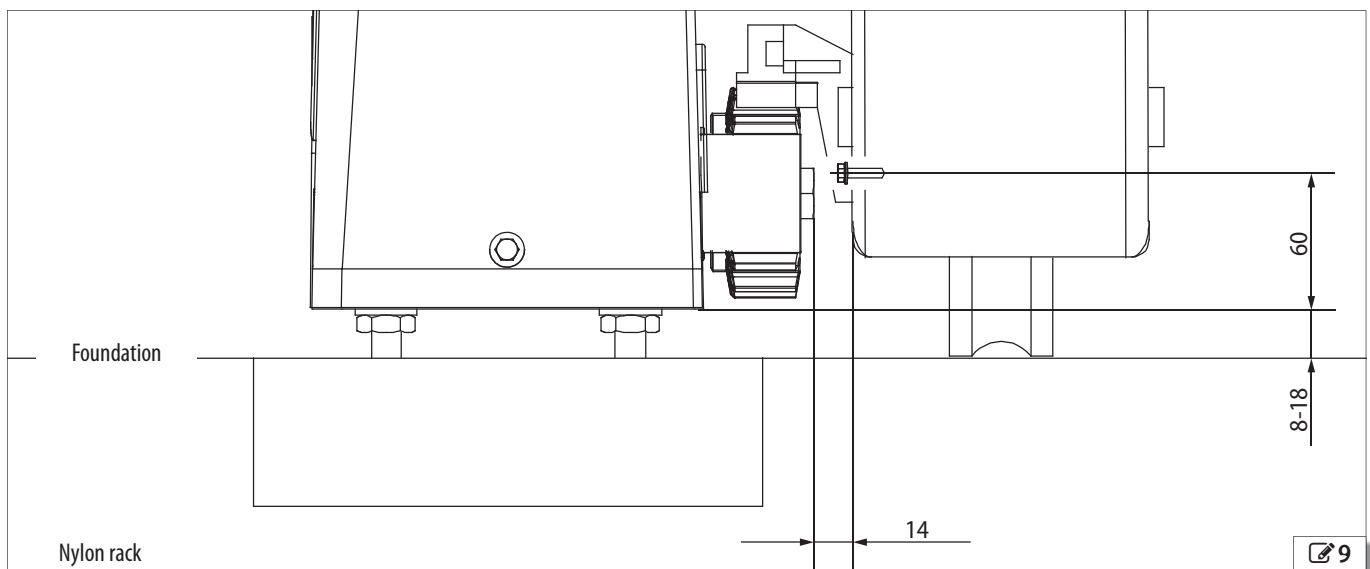

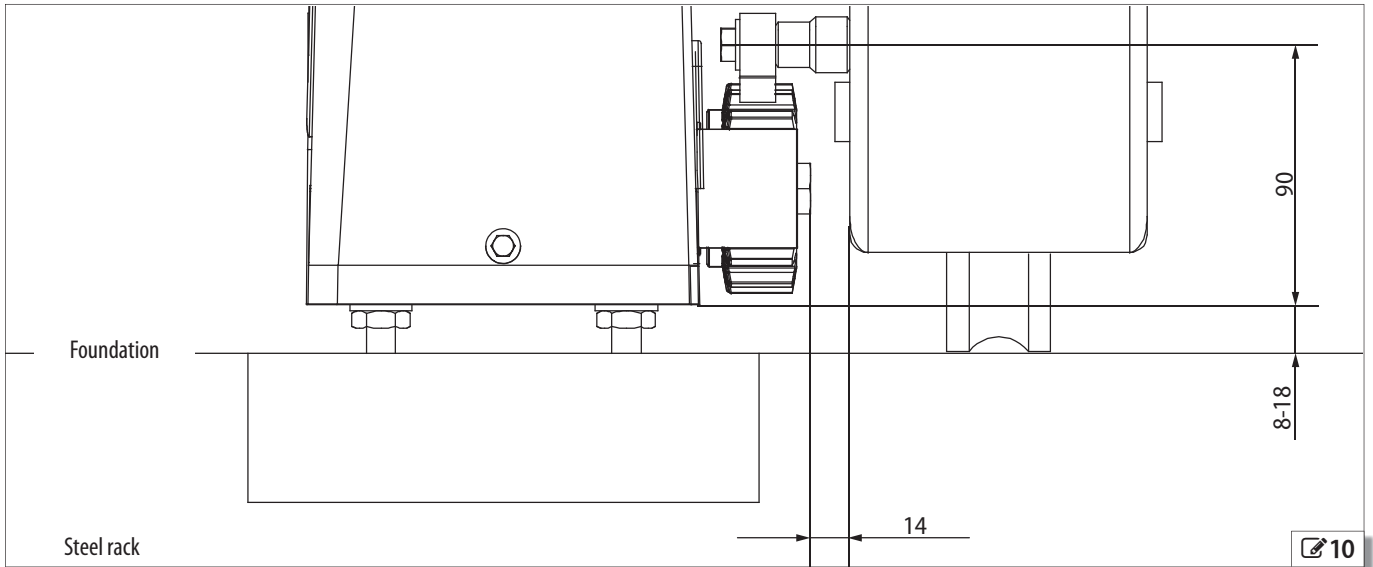

10

5.3 BASE PLATE

RISKS



PERSONAL PROTECTIVE EQUIPMENT



i Before proceeding, check that the necessary conduits are in place (§ 4.3-[5](#)).
The base plate and corresponding hardware are accessories which are not included.

1. Assemble the base plate as shown in [11](#); tighten the supplied M10 nuts and locknuts, using two hex spanners.
2. Pour a slab, with reference to [6](#) and [7](#) in § 5.2 and [12](#).
3. Take the cable conduits out from the hole ([12-1](#)) and install the base plate.

- i** Do not bury the base plate in the concrete.
4. Use a spirit level to check that the slab is horizontal, making any corrections before the concrete goes off ([12](#)).

5.4 FASTENING THE GEAR MOTOR

RISKS



PERSONAL PROTECTIVE EQUIPMENT



- i** Wait for the concrete to cure fully before proceeding.
- !** Lift the gear motor, holding it by the base.

1. Pass the cables through the two holes on the gear motor ([13-1](#)).
2. Position the gear motor, lining up the slots and the screws on the plate ([13-2](#)).
3. Pass the cables through the supplied cable glands, then insert the cable glands in the holes ([13-3](#)).

! If one of the two holes will not have cables running through it, insert the plastic cable gland whole.

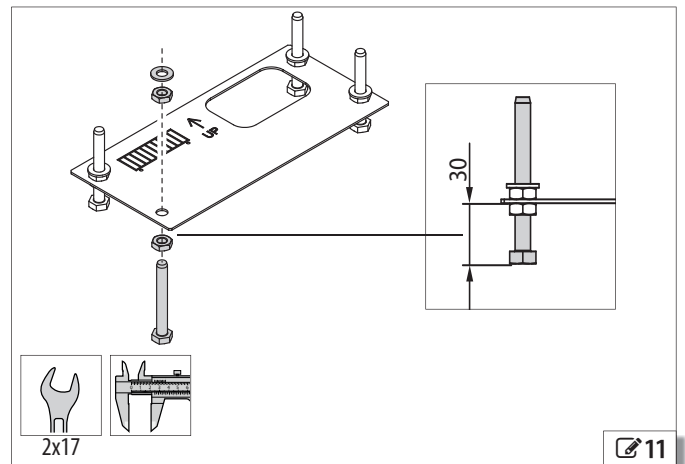

11

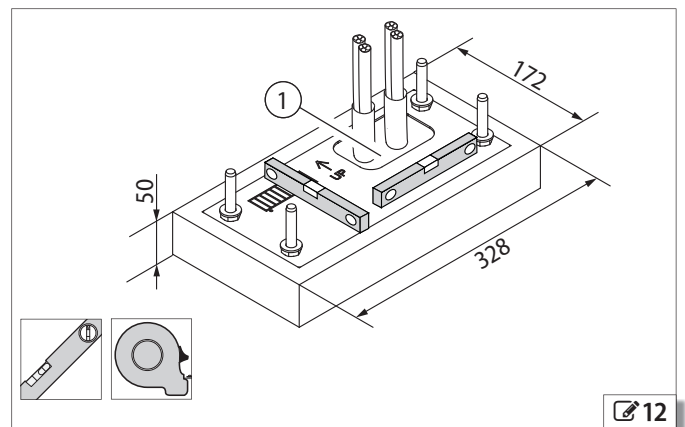

12

- Bring the base of the gear motor to 18mm from the base plate using the four support nuts (🔗 14-1).
- Fit four M10 locknuts and four washers, supplied with the base plate, as in 🔗 14-2.
- Ensure there is 13.5mm between the pinion and the sliding gate section (§ 5.2-🔗 9-🔗 10).
- Use a spirit level to check that the gear motor is horizontal (🔗 14); make any adjustments with the support nuts (🔗 14-1).
- Provisionally tighten the four locknuts using two hex spanners (🔗 14-1-2).

5.5 MANUAL OPERATION



Shut off the power to the system and ensure that the automation system is stopped before performing manual movement operations and restoring automatic operation.

A lock with personalised key is available as an optional accessory.

MANUAL RELEASE

- Open the plastic cap on the release device (🔗 15-1).
- Turn the lock clockwise using a coin or your personalised key (🔗 15-1).
- Turn the knob clockwise (🔗 15-2).

RESTORING AUTOMATIC OPERATION

- Turn the knob anticlockwise.
- Turn the lock anticlockwise.
- Manually move the gate until the mechanical system engages.

5.6 INSTALLING THE RACK

RISKS



PERSONAL PROTECTIVE EQUIPMENT



The rack installation accessories contain screws for aluminium or steel sliding gate sections. Use specific screws for other materials. Do not use grease or other lubricants.

Release the gear motor and close the gate manually (§ 5.5).

STEEL RACK WITH SPACERS TO BE WELDED ON



Do not weld the rack components to the spacers or to each other.

- Install the spacers and screws in the upper part of the slots (🔗 16-1): This will allow future adjustments if the rail is lowered.

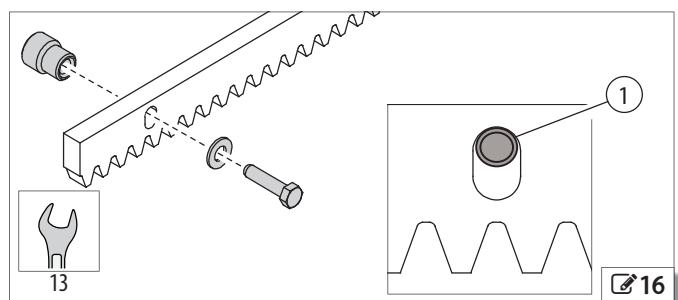
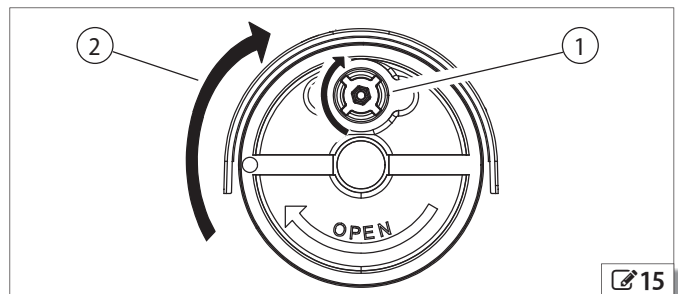
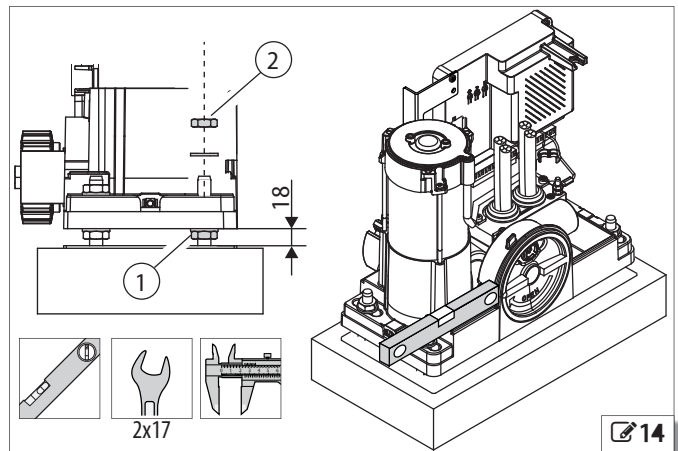
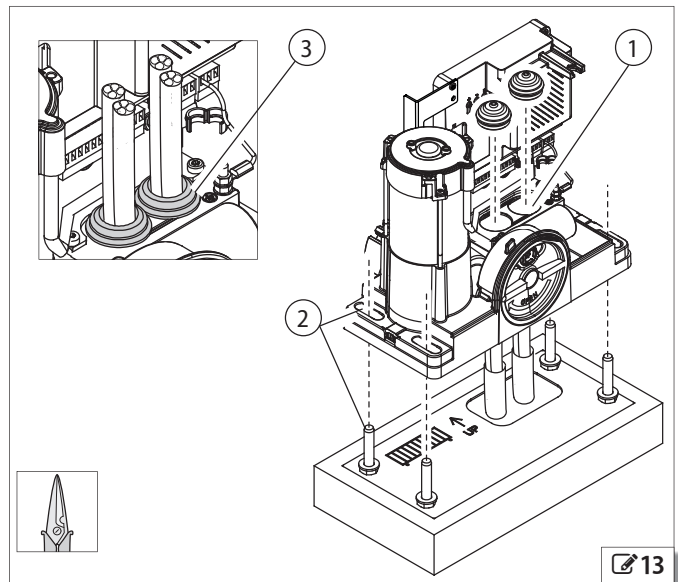

2. Rest the assembled component on the pinion.
3. Use a screw clamp to fasten the section to the sliding gate section, then use a spirit level to check it is level (🔗 17).
4. Weld the spacer to the sliding gate section (🔗 17-1).
5. Move the sliding gate section forward, checking that the section rests on the pinion.
6. Check the level, then weld the other two spacers, repeating the operations in steps 5 and 6.
7. If necessary, install another rack section, as in step 1.
8. Rest the section on the pinion, bringing it up to the previous one; use a third section, screw clamps and a spirit level to line up the teeth and check it is level (🔗 18).
9. Weld the spacers, repeating the operations in points 5, 6 and 7.
10. Add other rack sections until the entire length of the sliding gate section is covered.
11. If the final section is too long, cut it with an angle grinder near one of the slots (🔗 19).

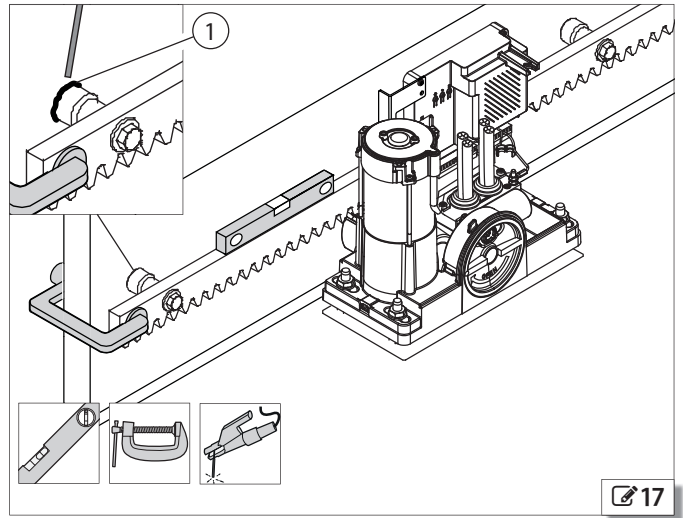

🔗 17

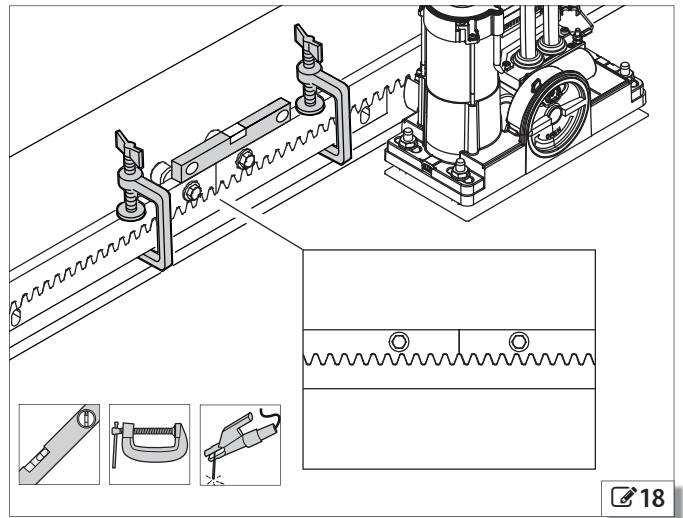

🔗 18

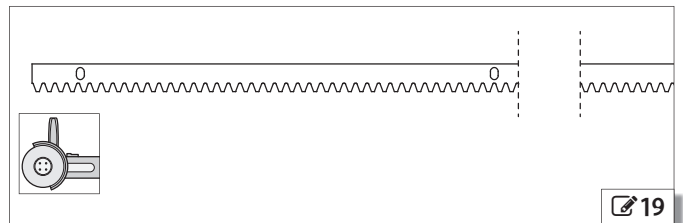

🔗 19

STEEL RACK WITH SPACERS TO BE SCREWED ON

1. Rest a rack section on the pinion (🔧 20).
2. Position the spacers in the upper part of the slots (🔧 20-1): This will allow future adjustments if the rail is lowered.
3. Use a screw clamp to fasten the assembly to the sliding gate section, then use a spirit level to check it is level (🔧 20).
4. Mark the point to drill into the sliding gate section (🔧 20-1). Drill with a 6.5mm bit and use an M8 thread cutter to tap the hole. Screw in the screw for the spacer with the corresponding washer (🔧 20-2).
5. Move the sliding gate section forward, checking that the section rests on the pinion.
6. Screw in the other two spacers, repeating the operations in steps 5 and 6.
7. If necessary, use another rack section; rest it on the pinion, bringing it up to the previous one; use a third section, screw clamps and a spirit level to line up the teeth and check it is level (🔧 21).
8. Install the section, repeating the operations in points 5, 6 and 7.
9. Add other rack sections until the entire length of the sliding gate section is covered.
10. If the final section is too long, cut it with an angle grinder near one of the three slots (🔧 22).

NYLON RACK AND MOUNTING HARDWARE

1. Rest a rack section on the pinion (🔧 23).
2. Use a screw clamp to fasten the assembly to the sliding gate section, then use a spirit level to check it is level (🔧 23).
3. Mark the drill point on the sliding gate section, in the upper part of the slot (🔧 23-1): This will allow future adjustments if the rail is lowered.
4. If the thickness of the tubular section is less than 5mm, screw in the self-tapping screw with its washer; if the thickness of the tubular section is greater than 5mm, drill with a 5.5mm bit then use a 6.3x25 hex-head self-tapping screw instead of the self-tapping screw (🔧 23-2).
5. Move the sliding gate section forward, checking that the section rests on the pinion.
6. Check the level, then screw in the other two screws, repeating the operations in steps 4, 5 and 6.

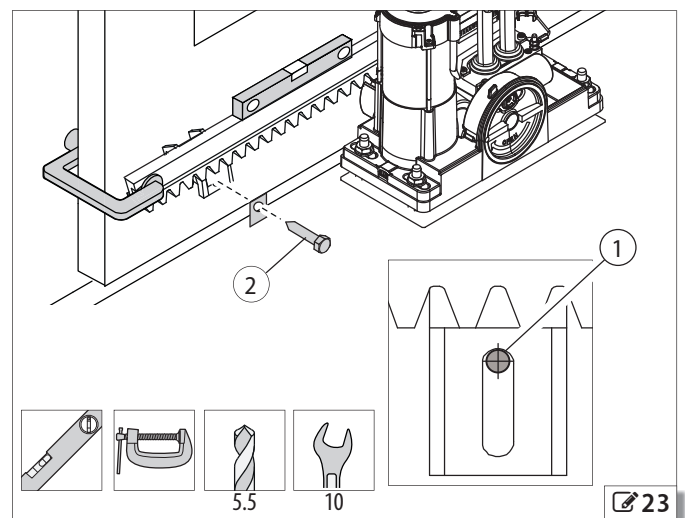
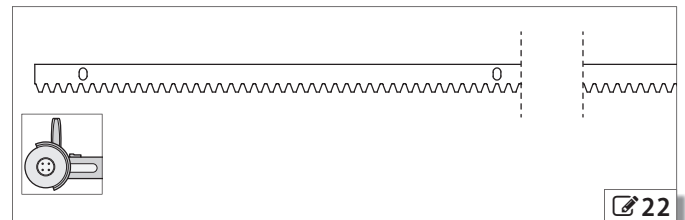
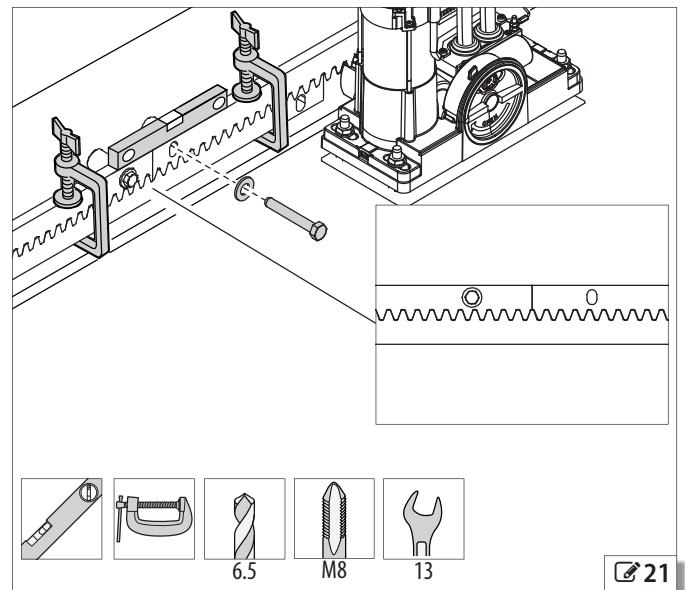
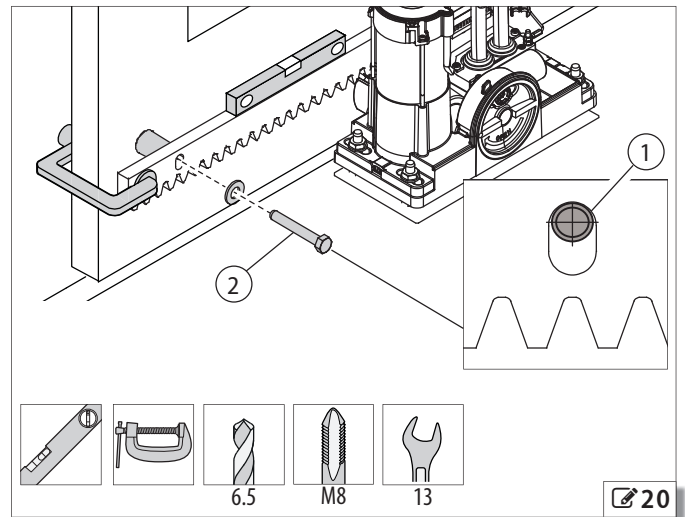

7. If necessary, use another section of rack; rest it on the pinion and connect it to the previous one and use a spirit level to check it is level (🔗 24).
8. Install the section, repeating the operations in points 4, 5, 6 and 7.
9. Add other rack sections until the entire length of the sliding gate section is covered.
10. If the final section is too long, cut it with an angle grinder near one of the three slots (🔗 25).

5.7 ADJUSTMENTS AND CHECKS

RISKS



PERSONAL PROTECTIVE EQUIPMENT



The operations described in this section are fundamentally important to the integrity and operation of the gear motor.

1. When you have installed the rack, lower the gear motor by 1.5mm (🔗 26-1), using the four support nuts (🔗 27-1).
2. Check that the gear motor is level using a spirit level (🔗 27).
3. Tighten the four upper locknuts to a minimum torque of 40Nm (🔗 27-2), using a hex spanner and a torque wrench.
4. Move the gate by hand and check that:
 - There is 1.5 mm between the teeth of the rack and pinion along the travel
 - The rack remains engaged with the pinion along its travel (🔗 26-2)
 - The sliding gate section and gear motor do not touch at any point
 - There is no friction.

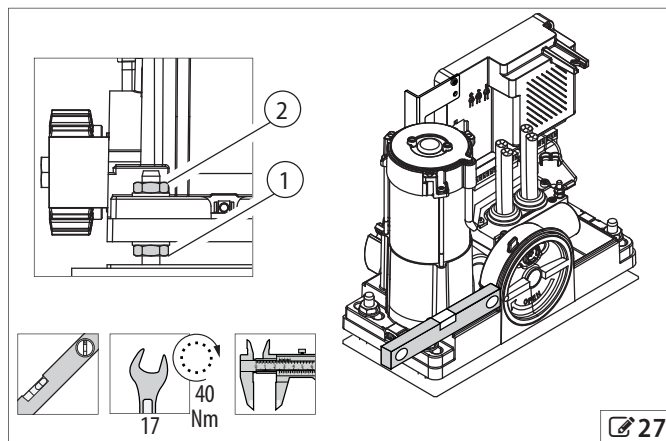
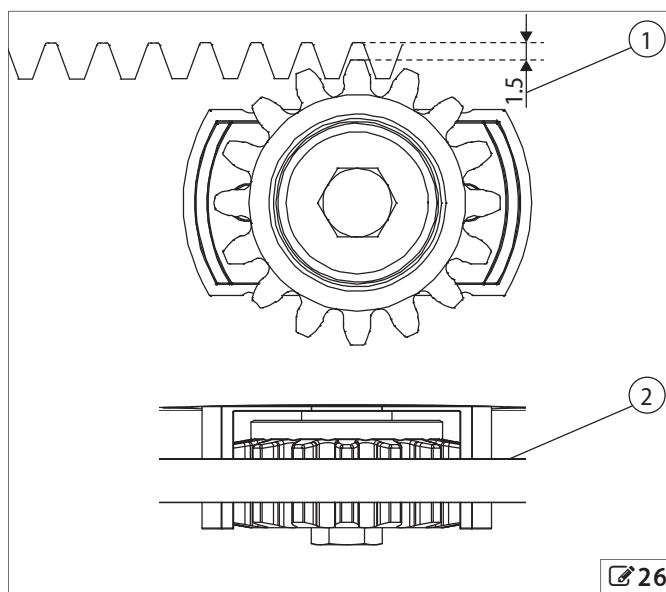
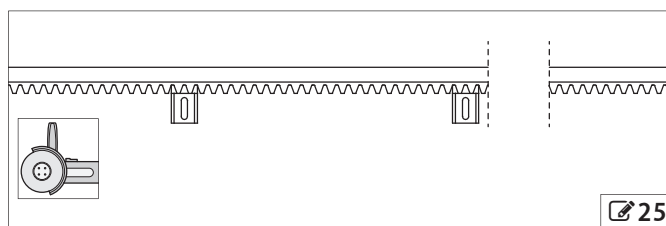
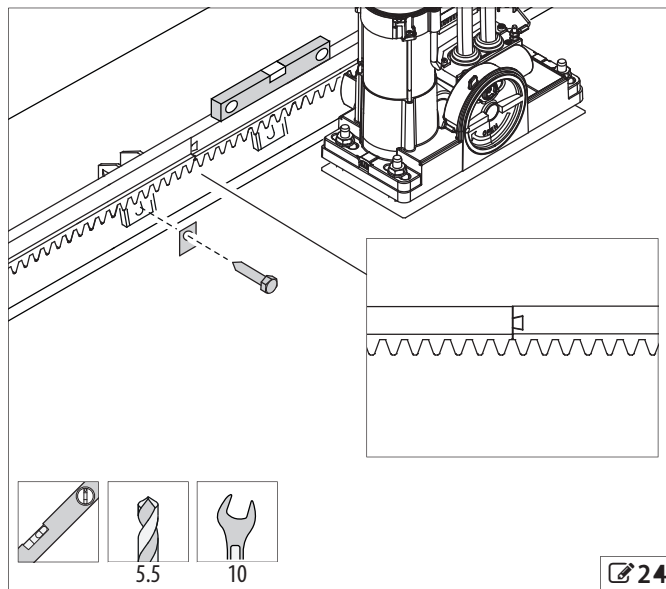

6. ELECTRONIC BOARD

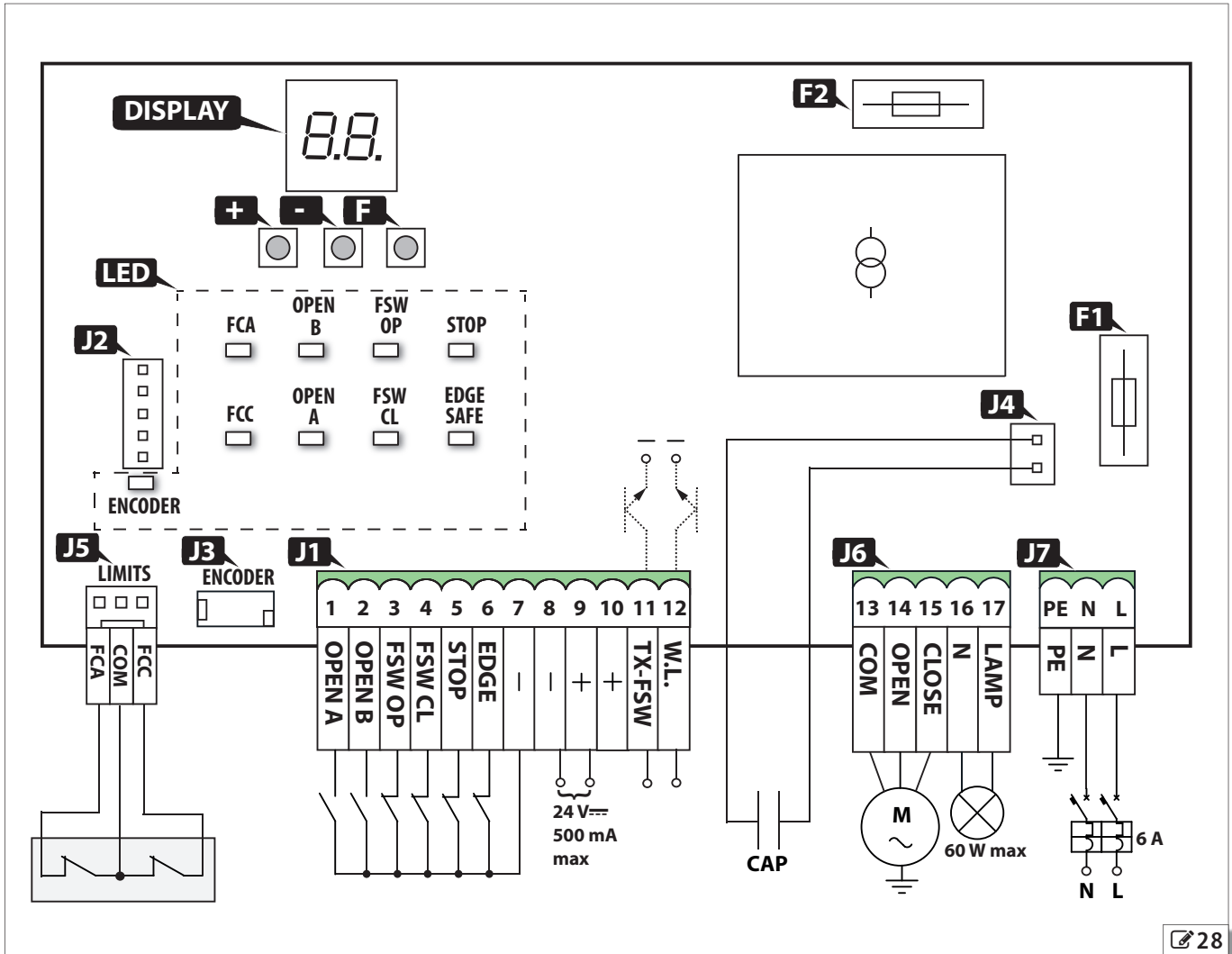

ENGLISH
Translation of the original instructions

28

KEY:	
J1	Terminal board for accessories
J2	Connector for GENIUS 5-pin receiver
J3	Rapid connector for encoder
J4	Rapid connector for start-up capacitor
J5	Rapid connector for the magnetic limit switch sensor
J6	Terminal board for motor and flashing light
J7	Terminal board for main power supply
F1	Fuse for main power supply
F2	Fuse for accessories power supply

LED:	
FCA	Limit switch
FCC	Limit switch
OPEN B	Partial opening command
OPEN A	Total opening command
FSW OP	Opening photocells
FSW CL	Closing photocells
STOP	Automation stop
EDGE SAFE	N.C. contact for sensitive edges
ENCODER	Incremental encoder

9 Technical Data

	SPRINT 382 (230 V~)	SPRINT 383 (115 V~)
Mains power supply	230 V~ (+6%...-10%) 50 Hz	115 V~ (+6%...-10%) 60 Hz
Max power	10 W	10 W
Max. motor power	1000 W	1200 W
Max. accessories load 24 V---	500 mA	500 mA
F1	5 A	10 A
F2	800 mA	800 mA
Ambient operating temperature	-20 °C - +55 °C	-20 °C - +55 °C
Flashing Light	230 V~ - 60 W	115 V~ - 60 W

6.1 TERMINAL BOARDS AND CONNECTORS

i Do not exceed the maximum load of the outputs.

J1
Terminal board for connecting the inputs and outputs (🔗 29).

🔌 10 J1 - Inputs and outputs

INPUTS

- 1 OPEN A** N.O. contact; if active, it commands the total opening of the gate. If multiple contacts are used, they must be connected in parallel (🔗 30).
- 2 OPEN B** N.O. contact; if active, it commands the partial opening of the gate. If multiple contacts are used, they must be connected in parallel (🔗 30).
- 3 FSW OP** N.C. contact for photocells during opening (§ 6.2).
- 4 FSW CL** N.C. contact for photocells during closing (§ 6.2).
- 5 STOP** N.C. stop contact (§ 6.2).
- 6 EDGE** N.C. contact for sensitive edges (§ 6.2).

OUTPUTS:

- 7-8 -** Negative for accessories.
- 9-10 +** Positive for accessories (24 V $\overline{\text{=}}$ /500 mA max).
- 11 TX-FSW** Fail-safe Test Output. Provides a negative pole for accessories supply (100 mA max). It can be used to carry out a functional test of the safety devices connected to the inputs FSW OP, FSW CL and EDGE. If the test fails, the gear motor does control the movement. Please refer to § 6.2 e § 7.4 📊 15.
- 12 W.L.** Programmable output (100 mA max). When active, it provides a negative for accessories. Default: indicator lamp (§ 7.4 📊 15-SP).

J2
Rapid connector for inserting the GENIUS 5-pin radio receiver (optional accessory). Plug in the receiver only when the board is not powered.

J3
Rapid connector for inserting the encoder (optional accessory in some models).

J4
Rapid connector for inserting the start-up capacitor. Alternatively, the capacitor can be connected across terminals 14 and 15 of J6.

J5
Rapid connector for inserting the magnetic limit stop sensor.

J6
Terminal board for connecting the motor and flashing light (🔗 31). The cable of the electric motor is connected during production.

🔌 11 J6 - Motor and Flashing Light

MOTOR OUTPUT:

13 COM	Common	Grey
14 OPEN	Opening	Black
15 CLOSE	Closing	Brown

FLASHING LIGHT OUTPUT:

16 N	Neutral
17 LAMP	Flashing lamp phase (230/115 V \sim): output active during movement and during the pre-flashing set in Programming (§ 7.4 📊 15-PF).

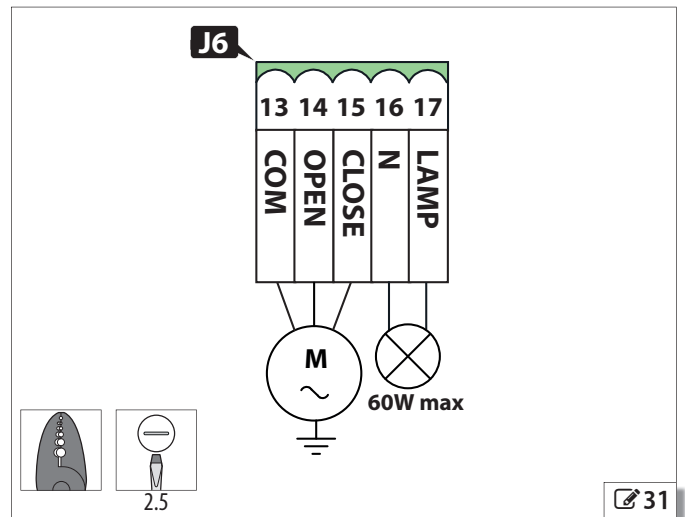
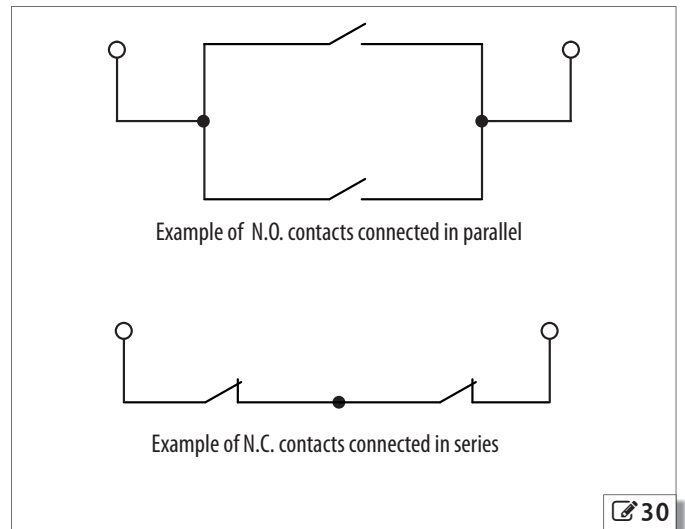
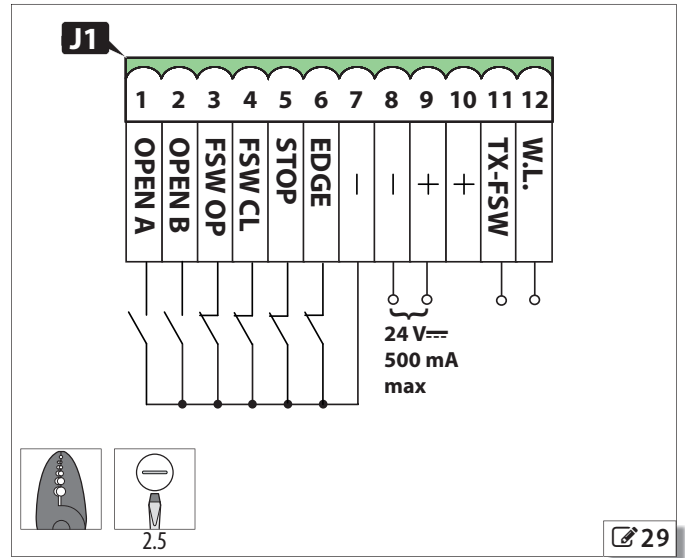

6.2 PHOTOCELLS AND SAFETY DEVICES

i The maximum current on terminal 11 is 100 mA: if the consumption is greater, replace it with a negative pole for accessories supply and do not enable the F_S and S_R functions in Advanced Programming.
The contacts described in this paragraph are N.C.

STOP

32 - If active, it prevents the gear motor from operating. If multiple contacts are used, they must be connected in series (**30**). If no contact is used, bridge terminals 5 and 7-8.

EDGE

33 - If active, reverses the movement for 2 seconds and stops the gear motor. It is usually used for connecting sensitive edges. If multiple contacts are used, they must be connected in series (**30**). If no contact is used, bridge terminals 6 and 11.

PHOTOCELLS DURING OPENING (FSW OP)

34 - If active, they trip during the opening movement of the gate; the outcome depends on a function in Advanced Programming (§ 7.4 **15-OP**). If multiple contacts are used, they must be connected in series (**36**). If no photocells are used, bridge terminals 3 and 11.

PHOTOCELLS DURING CLOSING (FSW CL)

35 - If active, they trip during the closing movement of the gate; the outcome depends on a function in Advanced Programming (§ 7.4 **15-CL**). If multiple contacts are used, they must be connected in series (**37**). If no photocells are used, bridge terminals 4 and 11.

PHOTOCELLS DURING OPENING AND CLOSING

38 shows an example of a pair of photocells when opening and closing. Their effects are described in § 9.

NO SAFETY CONTACT

If no safety contact is used, bridge the terminals as shown in **39**.

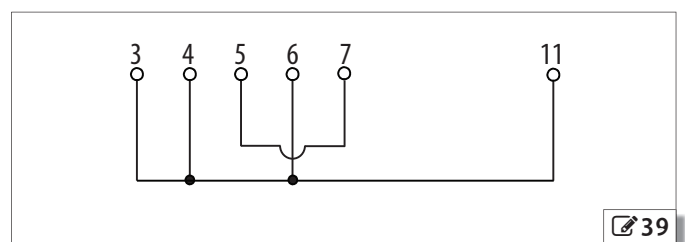
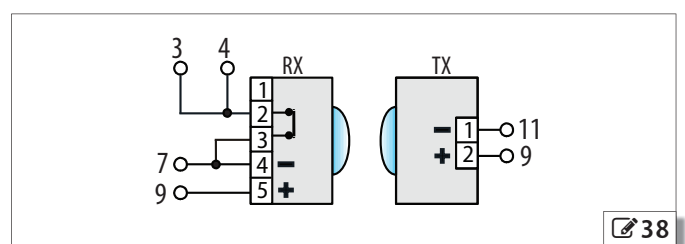
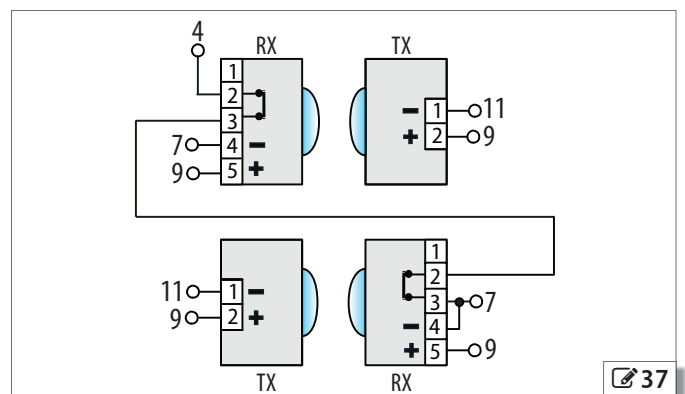
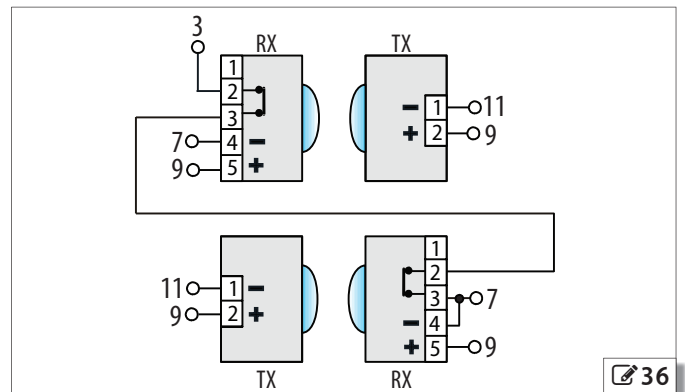
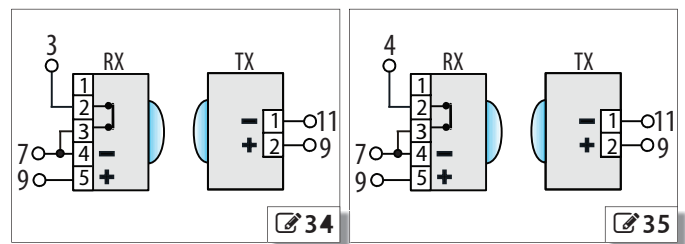
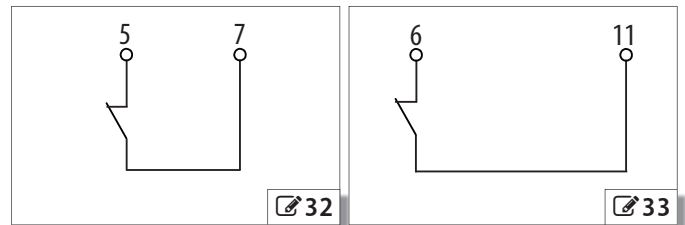

7. START-UP



During operation there is a risk of fingers and hands being trapped between the rack, pinion and casing.

The body of the electric motor can reach high temperatures during operation.

If the encoder is installed (🔧 42), make sure that it is connected to the board and activate the relative parameter in advanced programming (§ 7.4 📄 15-EC).



The flashing light, if connected to the board, indicates that the gate is moving.

7.1 POWER SUPPLY AND EARTHING

RISKS



Disconnect power to the system before making the connections and before removing the plastic cover of the electronic board. Before switching power on, make sure that you have replaced the plastic cover. Do not remove the earthing wire that is connected to terminal PE of J7 (🔧 40-1).

1. Crimp the electric motor and system earth wires together, using the supplied terminal (🔧 40-2).
2. Install the M5 nut, washer and terminal supplied onto the gear motor earth connection (🔧 40-3). Tighten the nut.
3. Connect the phase wires and neutral to terminals L and N respectively of J7 (🔧 40-4).

📄 12 J7 - Power supply

PE Earth: do not remove the wire.

N Neutral

L Phase



Secure the mains power supply wires using the appropriate clamp (🔧 41-1).

4. Switch on power to the system.

7.2 LEDS CHECK

1. Move the gate to its half-travel position.
2. Check that the status of the LEDS is the same as that shown in 📄 13. If it is not, check the connections (§ 6).

📄 13 LEDs Check

	STATUS	MEANING
FCA	■	§ 7.3
FCC	■	§ 7.3
OPEN B	□	Partial opening command not active
OPEN A	□	Total opening command not active
FSW OP	■	Opening photocells not engaged
FSW CL	■	Closing photocells not engaged
STOP	■	Stop not active
EDGE SAFE	■	Edge not active
ENCODER	■ / □	Flashing when moving

Key:

□ = LED off = open contact

■ = LED on = closed contact

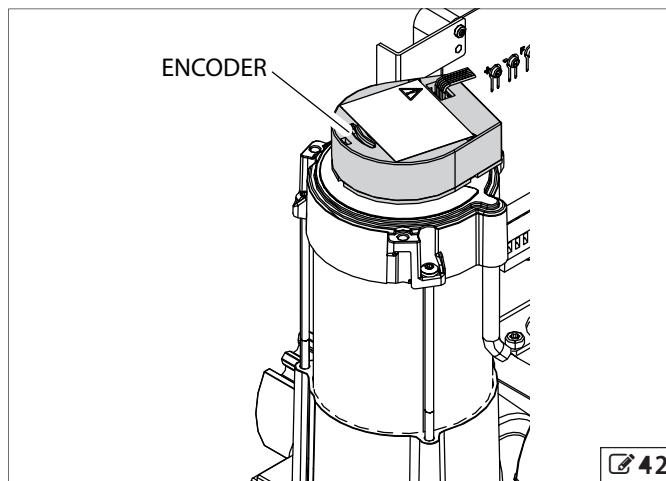
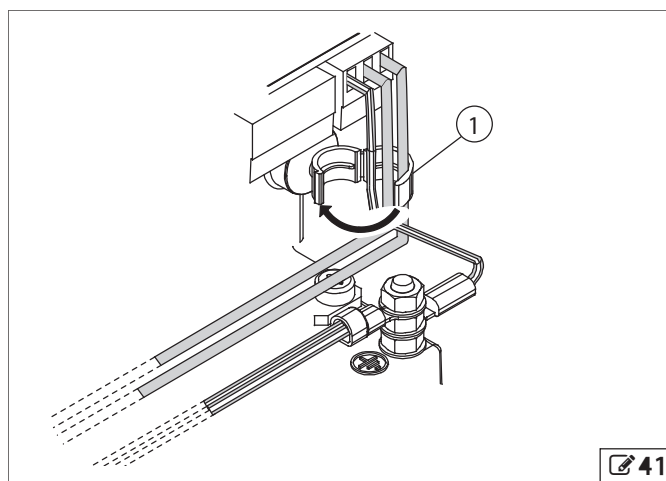
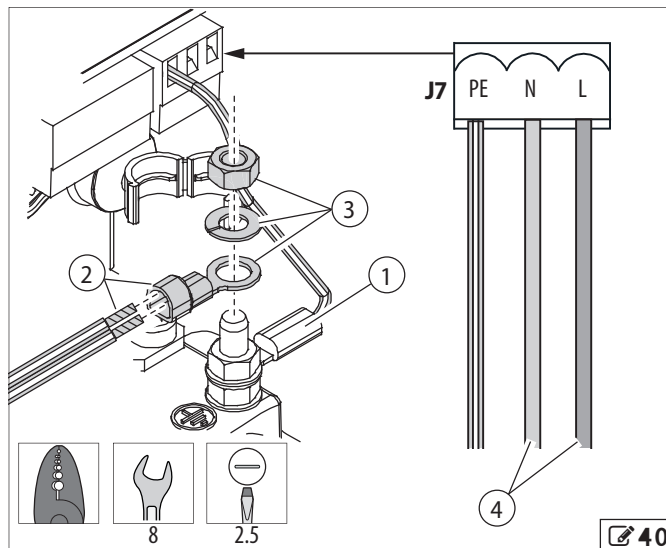

7.3 INSTALLATION OF THE LIMIT SWITCHES

RISKS



PERSONAL PROTECTIVE EQUIPMENT



OPENING TO THE RIGHT (43)

STATUS	LED FCA	LED FCC
CLOSING LIMIT SWITCH ENGAGED	■	□
NO LIMIT SWITCH ENGAGED	■	■
OPENING LIMIT SWITCH ENGAGED	□	■

OPENING TO THE LEFT (44)

STATUS	LED FCA	LED FCC
CLOSING LIMIT SWITCH ENGAGED	□	■
NO LIMIT SWITCH ENGAGED	■	■
OPENING LIMIT SWITCH ENGAGED	■	□

Key:

- = LED off = limit switch engaged
- = LED on = limit switch disengaged

1. Move the gate to the closed position by hand.
2. Position the closing magnetic limit switch (45) on the rack and look for the point at which the corresponding LED turns off.
3. Mark the centre of the limit switch slots on the rack; manually open the gate by 1m.
4. Drill a 3.6mm diameter hole corresponding to the central points of the slots. Fasten the limit switch using two 3.9x16 self-tapping screws and two washers (supplied) (45-1).
5. Manually move the gate back into its stop position when closed and check that the corresponding LED turns off. Otherwise, adjust the position of the limit switch using the slots.
6. Move the gate to the open position by hand.
7. Position the opening magnetic limit switch (46) on the rack and look for the point at which the corresponding LED turns off.
8. Mark the centre of the limit switch slots on the rack; manually close the gate by 1m.
9. Drill a 3.6mm diameter hole corresponding to the central points of the slots. Fasten the limit switch using two 3.9x16 self-tapping screws and two washers (supplied) (46-1).
10. Manually move the gate to its open position and check that the corresponding LED turns off. Otherwise, adjust the position of the limit switch using the slots.

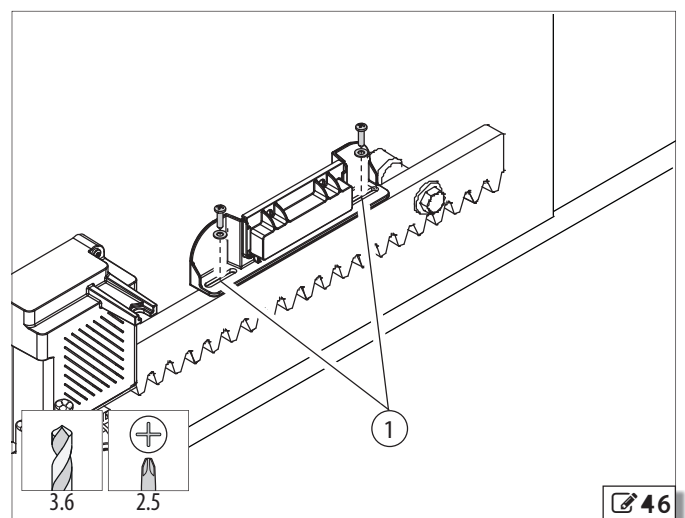
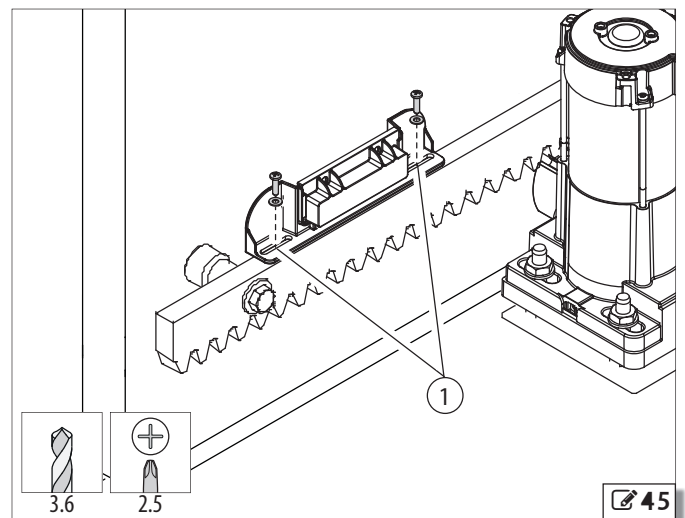
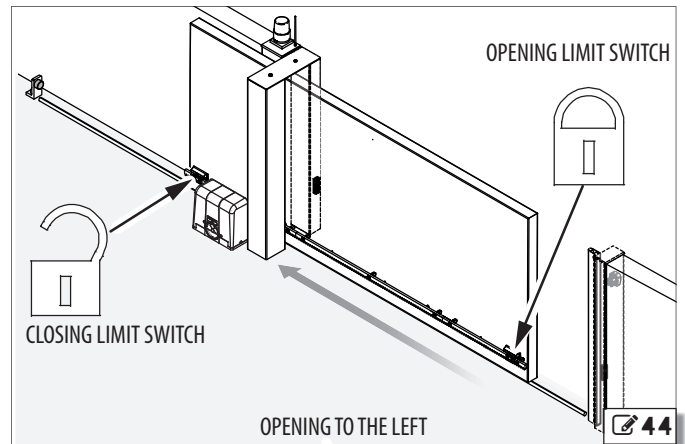
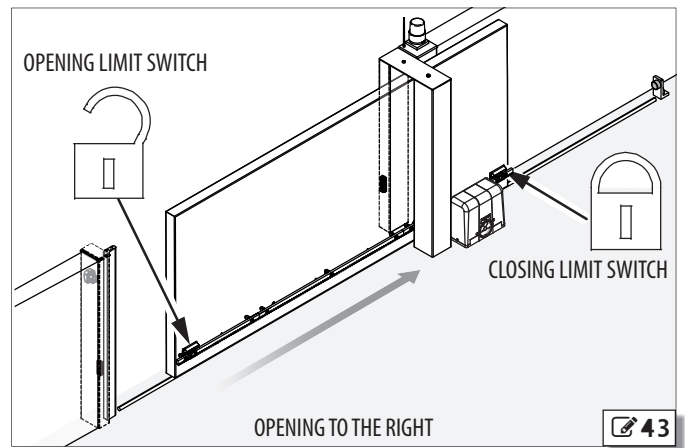

7.4 PROGRAMMING

The electronic board contains two Programming menus: Basic and Advanced.

- i** In order to save the modifications made to the functions, scroll through the menu until reaching gate status (St). If the mains power supply fails before the modifications are saved, all the modifications will be lost.
- To reset the default values for all the functions, open the EDGE contact (EDGE SAFE LED off) and press the +, - and F buttons simultaneously for 5 seconds.

BASIC PROGRAMMING

- To access the menu, press and hold down button F: the display shows the first function (L0).

- i** The display continues to show the name of the function as long as button F remains pressed.

- Release button F: the display shows the value of the function.
- Press the + or - buttons to modify the value of the function.
- Press and hold down button F to go to the next function.

ADVANCED PROGRAMMING

- To access the menu, press and hold down button F and then press the + button: the display shows the first function (b0).
- Release the + button whilst keeping button F pressed.

- i** The display continues to show the name of the function as long as button F remains pressed.

- Release button F: the display shows the value of the function.
- Press the + or - buttons to modify the value of the function.
- Press and hold down button F to go to the next function.

14 Basic Programming

BASIC PROGRAMMING		Default
L0	Operating logics (§ 9): R = Automatic RP = Automatic Step-by-Step S = Automatic "Safety" E = Semi-automatic EP = Semi-automatic Step-by-Step C = Dead Man b = Semi-automatic "B" bC = Mixed (b during opening / C during closing).	EP
PA	Pause time: This has an effect only if an automatic logic has been selected. Adjustable from 0 to 59, in 1 second steps. The display subsequently changes to minutes and tens of seconds, separated by a point, in 10 second steps up to a maximum of 4.1 minutes. E.g. 2.5=2 min. and 50 sec.	2.0
F0	Force: Regulates the thrust of the gear motor. 01 = Minimum power 50 = Maximum power	20
d1	Opening direction: Indicates the gate opening movement, using the body of the gear motor as a reference point (§ 7.3). -3 = Opening movement towards the right E- = Opening movement towards the left	-3
St	Gate status: Exit from programming function and view status. 00 = Closed 01 = When opening 02 = Stopped 03 = Open 04 = Open in pause 05 = Fail-safe Test failed (§ 6.1-10, § 6.2) 06 = When closing 07 = When reversing 08 = Photocells tripped	

15 Advanced Programming

ADVANCED PROGRAMMING		Default
b0	Maximum torque at initial thrust: If active, the motor operates at maximum power as soon as movement starts and ignores the F0 function. This is useful with heavy sliding gate sections. y = Active no = Disabled	y
br	Final braking: If active, it sets a braking stroke to ensure that the gate stops immediately when the gate engages the opening or closing limit switch. If decelerations have been set, braking starts when they end. 00 = Braking disabled. The braking time can be adjusted from 01 to 20, in 0.1 second steps. E.g. 10=1 second.	05

ADVANCED PROGRAMMING	Default
FS Fail-safe: If this function is active, it enables a functional test of the photocells before any movement of the gate occurs (§ 6.1-10, § 6.2). If the test fails, the gear motor does not control the movement. Y = Active no = Disabled	no
SA Safe: If active and FS=Y, it enables a functional test of the safety devices connected to the EDGE terminal before every gate movement (§ 6.1-10). Y = Active no = Disabled	no
PF Pre-flashing: If active, it sets a 5 second pre-flashing on the LAMP output (§ 6.1-11). no = disabled oP = only before opening CL = only before closing OC = before every movement	no
SP W.L.: (§ 6.1-10)  Do not exceed the maximum load of the output (24 V - 3 W). If necessary, use a relay and a power supply that is external to the board.	00
00 = standard indicator lamp (on during opening, when open and open in pause; flashing during closing; off when gate closed). From 01 to 4.1 = timed output . E.g. courtesy light: The time can be adjusted from 0 to 59, in 1 second steps and subsequently from 1.0 to 4.1 in 10 second steps. E1 = electric lock command before the opening movement. E2 = electric lock command before opening and closing movements. E3 = traffic light function : the output is active when the gate is open and open in pause. It is disabled 3 seconds before the closing manoeuvre starts, during which there are 3 seconds of pre-flashing on the LAMP output (§ 6.1-11). Disabled during closing and when the gate is closed. E4 = traffic light function: the output is active only in the closing state.	
PH Closing photocells logic: Sets the tripping mode of the photocells during closing (FSW CL). Y = Stop and reverse to opening when disengaged. no = Immediate reverse to opening	no
oP Opening photocells logic: Sets the tripping mode of photocells during opening (FSW OP). Y = Immediate reverse to closing no = Stop and reverse to opening when disengaged	no
EC Encoder: The encoder operates as an anti-crushing device: if the gate strikes an obstacle, it reverses the gate movement for 2 seconds. If, during the two seconds in which it reverses, another obstacle is encountered, it stops moving (SE=02). The sensitivity of the anti-crushing system must be set by regulating the function between 01 (maximum sensitivity) to 99 (minimum sensitivity). 00 = Encoder not installed or disabled 01-99 = Encoder active and sensitivity adjustment. The encoder also controls decelerations and partial opening.	00

ADVANCED PROGRAMMING	Default
rP Pre-limit switch deceleration: This sets the deceleration of the gate before the opening and closing limit switches are tripped. The time can be regulated from 00 to 99, in 0.1 second steps. If an encoder is installed and active, the deceleration is not determined on a time basis but by the number of motor revs, which enables a greater precision to be obtained. 00 = Deceleration disabled 01-99 = Deceleration active	10
rA Post-limit switch deceleration: This sets the deceleration of the gate after the opening and closing limit switches have been tripped. The time can be regulated from 00 to 20, in 0.1 second steps. If an encoder is installed and active, the deceleration is not determined on a time basis but by the number of motor revs, which enables a greater precision to be obtained. 00 = Deceleration disabled 01-20 = Deceleration active	05
PO Partial opening: This sets the partial opening width (OPEN B). It can be regulated from 01 to 20. If an encoder is installed and active, partial opening is determined by the number of motor revs, which enables a greater precision to be obtained.	05
t Cycle time-out: Set a value of 5 or 10 seconds more than the time it takes the gate to travel from one limit switch to another. This prevents the motor from overheating in the event that the limit switches are broken. It can be regulated from 0 to 59, in 1 second steps. The display subsequently changes to minutes and tens of seconds, separated by a point, in 10 second steps up to a maximum of 4.1 minutes. E.g. 2.5=2 min. and 50 sec.  The set value does not exactly correspond to the maximum operating time of the motor because this is modified by the deceleration times.	2.0
AS Assistance request: If active, at the end of the countdown of the following function ("Cycle programming") there are 2 seconds of pre-flashing on the LAMP output (§ 6.1-11), in addition to that set in the PF function, at every OPEN pulse. This can be useful for setting scheduled maintenance work. Y = Active no = Disabled	no
nc Cycle programming: This function is linked to the previous one ("Assistance request"). It allows a countdown for the operating cycles of the gear motor to be set. It is settable, in thousands, from 00 to 99 thousand cycles.	00
SE Gate status: Exit from the programming function and view the gate status (§ 7.4-14).	

7.5 DIRECTION OF MOVEMENT CHECK

RISKS



PERSONAL PROTECTIVE EQUIPMENT



Disconnect power to the system before making connections

The operations described in this section are essential for the proper operation of the gear motor.

1. Move the gate manually to its half-travel position and restore automatic operation (§ 5.5).
2. Make sure that both the FCC and FCA LEDs are lit.
3. Check that the magnetic limit switches are in the correct position (§ 7.3).
4. Check that the Δ function in Basic Programming (§ 7.4 14) is set correctly.
5. Turn the electronic board off and on again using the circuit breaker.
6. Open the gate (OPEN A); check that the gate actually performs an opening movement in correspondence with the status indicator on the display.
7. If it doesn't, invert the two electric motor phase wires: J6, terminals 14 and 15 (§ 6.1 11). Repeat the operations indicated in points 5 and 6.
8. Check that the gate stops automatically when both limit switches are tripped. In particular:
 - the display must indicate status or in correspondence with the opening limit switch.
 - the display must indicate status in correspondence with the closing limit switch.

7.6 FINAL OPERATIONS

RISKS



PERSONAL PROTECTIVE EQUIPMENT



1. Ensure that the forces generated by the leaf are within the limits allowed by the standard. Use an impact curve gauge in accordance with standards EN 12453 and EN 12445. For countries outside the EU, when there is no specific local standard, the force must be less than 150 N static.
2. Ensure that the maximum manual moving force of the leaf is less than 225 N.
3. Use appropriate signs to highlight the areas where residual risks remain despite having implemented all safety measures.
4. Put up the "DANGER: AUTOMATIC MOVEMENT" sign on the gate in a visible position.
5. Put up the CE marking on the gate.
6. Complete the EC Declaration of Conformity of the machine and the system Logbook.
7. Provide the owner/operator of the automation with the EC Declaration, the system Logbook with the maintenance schedule and the user instructions of the automation.

INSTALLING THE CASING



Mount the casing following the instructions in 47: choose between the hexagonal insert screws and the Allen screws provided, size M5.

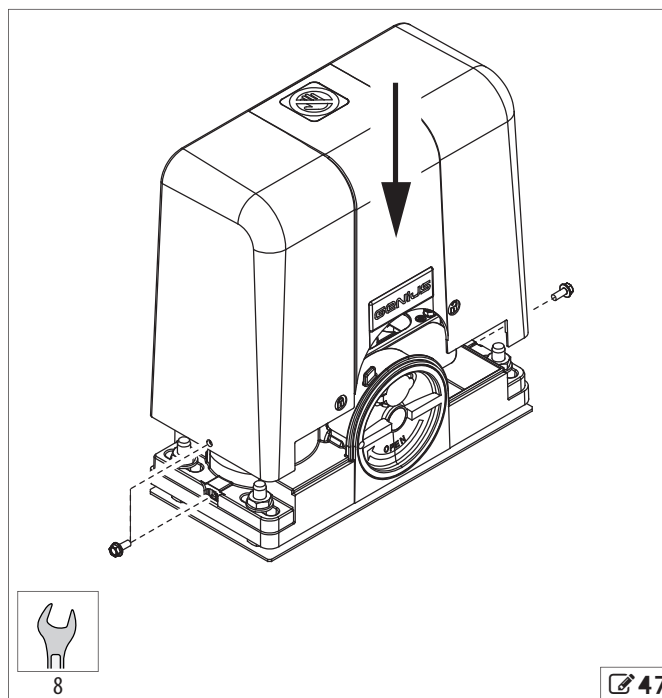

8. MAINTENANCE

RISKS



PERSONAL PROTECTIVE EQUIPMENT



Always shut off the power supply before performing any maintenance operations. If the disconnect switch is not in view, apply a warning sign stating "WARNING - Maintenance in Progress". Restore the power supply only after finishing any maintenance work and restoring the area to normal.

Maintenance must be performed by the installer or a maintenance technician.

Follow all safety recommendations and instructions given in this manual.

Mark off the work site and prohibit access/transit. Do not leave the work site unguarded.

The work site must be kept tidy, and cleared at the conclusion of maintenance operations.

Before starting work, wait for any hot components to cool down.

Do not make any modifications to the original components.

FAAC S.p.A. shall bear no liability for damage or injury due to components which have been modified or otherwise tampered with.

This shall also cause the warranty to lapse.

Make replacements only using original GENIUS spare parts.

8.1 SCHEDULED MAINTENANCE

The Scheduled Maintenance Table 16 lists the operations which must be performed on a regular basis in order to keep the automation system working reliably and safely; these are given purely as a guideline and should not be considered exhaustive. The installer/machine manufacturer is responsible for drawing up the maintenance plan for the automation system, supplementing this list or modifying the maintenance operations on the basis of the machine characteristics.

16 Scheduled Maintenance

Operations	Frequency
Structures	
Check the slab, the structures and components of the building/fence adjacent to the automation system, ensuring there is no damage, cracking or subsidence.	12
Check the gate's area of movement, ensuring it is free from obstacles, objects or deposits which would reduce the effectiveness of the safety measures.	12
Check that there are no gaps in the perimeter fence and that any protective grilles in the area where it overlaps with the sliding gate section are intact.	12
Ensure that there are no sharp protrusions which could represent a perforation or hooking hazard.	12
Gate	
Check the gate, ensuring it is intact and free of deformations, rust etc.	12
Check that there are no slots/openings on the gate and that any protective grilles are intact.	12
Check that screws and bolts are correctly tightened.	12
Check that the sliding guides are straight and not excessively worn.	12
Check that the bearings are in good condition and there is no friction.	12
For cantilever systems, check the solidity of the guide system for the suspended gate section and the counterweight, where present.	12
Check that the mechanical strikes are fastened solidly and in good condition. This check must be performed on both sides, simulating any knocks which could occur during use.	12
Check the wheels, ensuring that they are intact, correctly fastened and free of deformation, wear and rust.	12
Check the rack, ensuring it is straight, spaced correctly from the pinion along its entire length, and correctly fastened to the gate.	12
Check the containing guide and the anti-tipping column, ensuring they are correctly fastened and intact.	12
Perform a general clean of the area of movement of the gate.	12
Gear Motor	
Check that the gear motor is intact and correctly fastened.	12
Check that the pinion is correctly keyed to the shaft and tightened correctly.	12
Check that the hand guard around the pinion is present and intact.	12
Check that it is irreversible.	12
Check that there is no loss of grease.	12
Check the condition of the gear motor cables, the cable glands and junction boxes.	12
Electronic Equipment	
Check that the power supply and connecting cables and the cable glands are intact.	12
Check that the connectors and wiring are intact.	12
Check that there are no signs of overheating, burning etc. of electronic components.	12
Check that the earth connections are intact.	12
Check the operation of the circuit breaker and RCD.	12
Check that the limit switch is intact and that it operates correctly.	12
Control Devices	
Check that the installed devices and remote controls are in good condition and that they operate correctly.	12
Sensitive Edges	
Check condition, fastening and correct operation.	6
Deformable Edges	
Check that they are intact and correctly fastened.	12
Photocells	
Check condition, fastening and correct operation.	6
Check the posts, ensuring that they are intact, correctly fastened and free of deformation etc.	6
Flashing Light	
Check condition, fastening and correct operation.	12
Electric Locks	
Check condition, fastening and correct operation.	12
Clean the seats.	12

Access Controls

Check that the gate opens only when an authorised user is recognised. 12

Complete Automation System

Check that the automation system operates correctly, following the set logic, when using the various control devices. 12

Check that the gate moves correctly - smooth, regular and without abnormal noise. 12

Check that both the opening and closing speed are correct and that the stop positions and slow-downs provided for are respected. 12

Check that the manual release operates correctly: when the release mechanism is activated, it must only be possible to move the gate manually. 6

Check that the caps on the locks are present. 6

Check that the maximum force required for manual movement of the gate is below 225 N in residential areas and 390 N in industrial or commercial settings. 6

Check that the safety edges operate correctly when faced with an obstacle. 6

Check that the encoder (where present) functions correctly when an obstacle is detected. 6

Check that each pair of photocells is working correctly. 6

Check that there is no optical/light interference between the pairs of photocells. 6

Check the force limitation curve (per EN 12453 and EN 12445). 6

Check that all necessary signage and warnings are present, intact and legible: residual risks, exclusive use etc. 12

Check that the gate's CE marking and the DANGER, AUTOMATIC MOVEMENT warning signage is present, intact and legible. 12

9. OPERATING LOGICS



In logics A, AP and S, the maintained commands OPEN A and OPEN B prolong the OPEN IN PAUSE status until they are disabled (E.g. by TIMER). The effects on the other active inputs are shown in brackets.

LOGIC A: AUTOMATIC

GATE STATUS	PULSES		SAFETY DEVICES				
	OPEN A	OPEN B	STOP	FSW OP	FSW CL	FSW CL/OP	EDGE
CLOSED	Opens. Closes after the pause time	Opens partially. Closes after the pause time	No effect (OPEN disabled)	No effect (OPEN disabled)	No effect	No effect (OPEN disabled)	No effect (OPEN disabled)
WHEN OPENING	No effect	No effect	Stops	§ 7.4- 15-	No effect	Stops. Opens when disengaged	Reverses to closing for 2 seconds
OPEN IN PAUSE	Resets pause time	Resets pause time	Stops	No effect	Resets pause time (OPEN disabled)	Resets pause time (OPEN disabled)	No effect (OPEN disabled)
WHEN CLOSING	Opens	Opens	Stops	No effect (memorizes OPEN)	§ 7.4- 15-	Stops. Opens when disengaged	Reverses to opening for 2 seconds*
STOPPED	Closes	Closes	No effect (OPEN disabled)	No effect	No effect	No effect (OPEN disabled)	No effect (OPEN disabled)

LOGIC AP: AUTOMATIC STEP-BY-STEP

GATE STATUS	PULSES		SAFETY DEVICES				
	OPEN A	OPEN B	STOP	FSW OP	FSW CL	FSW CL/OP	EDGE
CLOSED	Opens. Closes after pause time	Opens partially; closes after pause time	No effect (OPEN disabled)	No effect (OPEN disabled)	No effect	No effect (OPEN disabled)	No effect (OPEN disabled)
WHEN OPENING	Stops	Stops	Stops	§ 7.4- 15-	No effect	Stops. Opens when disengaged	Reverses to closing for 2 seconds
OPEN IN PAUSE	Stops	Stops	Stops	No effect	Resets pause time (OPEN disabled)	Resets pause time (OPEN disabled)	No effect (OPEN disabled)
WHEN CLOSING	Opens	Opens	Stops	No effect (memorizes OPEN)	§ 7.4- 15-	Stops. Opens when disengaged	Reverses to opening for 2 seconds*
STOPPED	Closes	Closes	No effect (OPEN disabled)	No effect	No effect	No effect (OPEN disabled)	No effect (OPEN disabled)

LOGIC S: AUTOMATIC SAFETY

GATE STATUS	PULSES		SAFETY DEVICES				
	OPEN A	OPEN B	STOP	FSW OP	FSW CL	FSW CL/OP	EDGE
CLOSED	Opens. Closes after pause time	Opens partially. Closes after pause time	No effect (OPEN disabled)	No effect (OPEN disabled)	No effect	No effect (OPEN disabled)	No effect (OPEN disabled)
WHEN OPENING	Closes	Closes	Stops	§ 7.4- 15-	No effect	Stops. Opens when disengaged	Reverses to closing for 2 seconds
OPEN IN PAUSE	Closes	Closes	Stops	No effect	Closes after 5 sec. (OPEN disabled)	Closes after 5 sec. (OPEN disabled)	No effect (OPEN disabled)
WHEN CLOSING	Opens	Opens	Stops	No effect (memorizes OPEN)	§ 7.4- 15-	Stops. Opens when disengaged	Reverses to opening for 2 seconds*
STOPPED	Closes	Closes	No effect (OPEN disabled)	No effect	No effect	No effect (OPEN disabled)	No effect (OPEN disabled)

LOGIC E: SEMI-AUTOMATIC

GATE STATUS	PULSES		SAFETY DEVICES				
	OPEN A	OPEN B	STOP	FSW OP	FSW CL	FSW CL/OP	EDGE
CLOSED	Opens	Opens partially	No effect (OPEN disabled)	No effect (OPEN disabled)	No effect	No effect (OPEN disabled)	No effect (OPEN disabled)
WHEN OPENING	Stops	Stops	Stops	§ 7.4-15-OP	No effect	Stops. Opens when disengaged	Reverses to closing for 2 seconds
OPEN	Closes	Closes	Stops	No effect	No effect (OPEN disabled)	No effect (OPEN disabled)	No effect (OPEN disabled)
WHEN CLOSING	Opens	Opens	Stops	No effect (memorizes OPEN)	§ 7.4-15-OP	Stops. Opens when disengaged	Reverses to opening for 2 seconds*
STOPPED	Closes**	Closes**	No effect (OPEN disabled)	No effect	No effect	No effect (OPEN disabled)	No effect (OPEN disabled)

LOGIC EP: SEMI-AUTOMATIC STEP-BY-STEP

GATE STATUS	PULSES		SAFETY DEVICES				
	OPEN A	OPEN B	STOP	FSW OP	FSW CL	FSW CL/OP	EDGE
CLOSED	Opens	Opens partially	No effect (OPEN disabled)	No effect (OPEN disabled)	No effect	No effect (OPEN disabled)	No effect (OPEN disabled)
WHEN OPENING	Stops	Stops	Stops	§ 7.4-15-OP	No effect	Stops. Opens when disengaged	Reverses to closing for 2 seconds
OPEN	Closes	Closes	Stops	No effect	No effect (OPEN disabled)	No effect (OPEN disabled)	No effect (OPEN disabled)
WHEN CLOSING	Stops	Stops	Stops	No effect (memorizes OPEN)	§ 7.4-15-OP	Stops. Opens when disengaged	Reverses to opening for 2 seconds*
STOPPED	Restarts in the opposite direction. Always closes after STOP	Restarts in the opposite direction. Always closes after STOP	No effect (OPEN disabled)	No effect (OPEN disabled if it has to open)	No effect (OPEN disabled if it has to close)	No effect (OPEN disabled)	No effect (OPEN disabled)

LOGIC C: DEAD-MAN

GATE STATUS	MAINTAINED COMMANDS		SAFETY DEVICES				
	OPEN A	OPEN B	STOP	FSW OP	FSW CL	FSW CL/OP	EDGE
CLOSED	Opens	No effect	No effect (OPEN A disabled)	No effect (OPEN A disabled)	No effect (OPEN B disabled)	No effect (OPEN A disabled)	No effect (OPEN disabled)
WHEN OPENING	-	Stops	Stops	Stops (OPEN A disabled)	No effect	Stops (OPEN disabled)	Reverses to closing for 2 seconds
OPEN	No effect	Closes	No effect (OPEN B disabled)	No effect (OPEN A disabled)	No effect (OPEN B disabled)	No effect (OPEN B disabled)	No effect (OPEN disabled)
WHEN CLOSING	Stops	-	Stops	No effect	Stops (OPEN B disabled)	Stops (OPEN disabled)	Reverses to opening for 2 seconds*

Translation of the original instructions

ENGLISH

LOGIC B: SEMI-AUTOMATIC B

GATE STATUS	PULSES		SAFETY DEVICES				
	OPEN A	OPEN B (CLOSE)	STOP	FSW OP	FSW CL	FSW CL/OP	EDGE
CLOSED	Opens	No effect	No effect (OPEN A disabled)	No effect (OPEN A disabled)	No effect (OPEN B disabled)	No effect (OPEN A disabled)	No effect (OPEN disabled)
WHEN OPENING	No effect	No effect	Stops	Stops (OPEN A disabled)	No effect	Stops (OPEN disabled)	Reverses to closing for 2 seconds
OPEN	No effect	Closes	No effect (OPEN B disabled)	No effect (OPEN A disabled)	No effect (OPEN B disabled)	No effect (OPEN B disabled)	No effect (OPEN disabled)
WHEN CLOSING	Opens	No effect	Stops	No effect	Stops (OPEN B disabled)	Stops (OPEN disabled)	Reverses to opening for 2 seconds*
STOPPED	Opens	Closes	No effect (OPEN disabled)	No effect (OPEN A disabled)	No effect (OPEN B disabled)	No effect (OPEN disabled)	No effect (OPEN disabled)

LOGIC BC: MIXED

GATE STATUS	PULSES	MAINTAINED COMMANDS	SAFETY DEVICES				
	OPEN A	OPEN B (CLOSE)	STOP	FSW OP	FSW CL	FSW CL/OP	EDGE
CLOSED	Opens	No effect	No effect (OPEN A disabled)	No effect (OPEN A disabled)	No effect	No effect (OPEN A disabled)	No effect (OPEN A disabled)
WHEN OPENING	No effect	No effect	Stops	No effect (memorizes OPEN A)	No effect	Stops (OPEN disabled)	Reverses to closing for 2 seconds
OPEN	No effect	Closes	No effect (OPEN B disabled)	No effect	No effect (OPEN B disabled)	No effect (OPEN B disabled)	No effect (OPEN disabled)
WHEN CLOSING	Opens	No effect	Stops	No effect (memorizes OPEN A)	Stops (OPEN B disabled)	Stops (OPEN disabled)	Reverses to opening for 2 seconds*
STOPPED	Opens	Closes	No effect (OPEN disabled)	No effect (OPEN A disabled)	No effect (OPEN B disabled)	No effect (OPEN disabled)	No effect (OPEN disabled)

* If a new pulse occurs within two seconds of reversing, it immediately stops the operation.

** With the photocells engaged during closing, the second command causes it to open.

10. INSTRUCTIONS FOR USE

It is the responsibility of the machine installer/manufacturer to draft the user instructions of the automation in accordance with the Machinery Directive, including all the required information and instructions based on the characteristics of the automation.

The guidelines below, which are purely indicative and in no way exhaustive, help the installer draft the user instructions.



The installer must provide the owner/operator of the automation with the EC Declaration, the system Logbook with the maintenance schedule and the user instructions of the automation.

The installer must inform the owner/operator of any residual risks and the intended use and ways in which the machine should not be used.

The owner is responsible for operating the automation and must:

- comply with all User instructions provided by the installer/maintenance technician and the Safety recommendations
- keep the user instructions
- have the maintenance schedule implemented
- keep the system Logbook, which must be completed by the maintenance technician at the end of all servicing

10.1 SAFETY RECOMMENDATIONS

Installations of GENIUS BLIZZARD 500-900 C series gear motors must be used for vehicular traffic.

The user must be in good physical and mental health and be aware of and responsible for the dangers which use of the product can lead to.



- Do not remain in or walk/drive through the area of operation of the automation system while it is moving.
- Do not use the automation system when the area of operation is not free of persons, animals or objects.
- Do not allow children to approach or play in the area of operation of the automation system.
- Do not try to prevent the movement of the automation system.
- Do not climb on, hold onto or let yourself be pulled by the gate. Do not climb onto or sit on the gear motor.
- Do not allow the devices to be used by anyone who is not specifically authorised and trained to do so.
- Do not allow the devices to be controlled by children or persons with mental and physical deficiencies unless they are supervised by an adult who is responsible for their safety.
- Do not use the automation system with the fixed and/or mobile guards removed or altered.
- Do not use the automation system in the presence of faults which could compromise safety.
- Do not expose the automation system to corrosive chemical or atmospheric agents; do not expose the gear motor to corrosive chemical or atmospheric agents.
- Do not expose the automation system to flammable gases or fumes.
- Do not perform any work on the components of the automation system.

10.2 PRODUCT WARNINGS



Risk of fingers and hands being trapped between the rack, pinion and casing (§ 3.8- 2).

10.3 EMERGENCY USE

Environmental phenomena, even occasional, such as ice, snow and strong wind may hinder correct operation of the automation and affect component integrity and may become a potential source of danger.

In any malfunction, emergency or fault, disconnect the power supply of the automation. If the conditions allow the leaf to be safely moved manually, use the manual operation; otherwise, keep the automation out of service until it is restored/repaired.

In case of a fault, the automation must be restored/repaired must only be carried out by the installer/maintenance technician.

10.4 MANUAL OPERATION



Before performing the release operation, shut off the power supply to the automation system.

During manual operation, gently guide the gate the whole way. Do not push it and let it slide freely.

Do not leave the gate with the release engaged: after moving it manually, restore automatic operation.

RELEASE OPERATION

1. Open the plastic cap on the release device (48-1).
2. Turn the lock clockwise using a coin or your personalised key (48-1).
3. Turn the knob clockwise (48-2).

RESTORING AUTOMATIC OPERATION

1. Turn the knob anticlockwise.
2. Turn the lock anticlockwise.
3. Manually move the gate until the mechanical system engages.

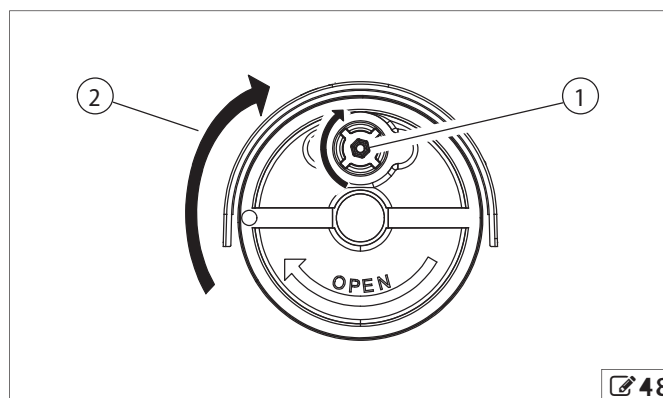

GENIUS[®]

Sede legale: FAAC S.p.A. Soc. Unipersonale
Via Calari, 10 - 40069 Zola Predosa BOLOGNA - ITALY
Tel. +39 051 61724 - Fax +39 051 758518
www.geniusg.com