

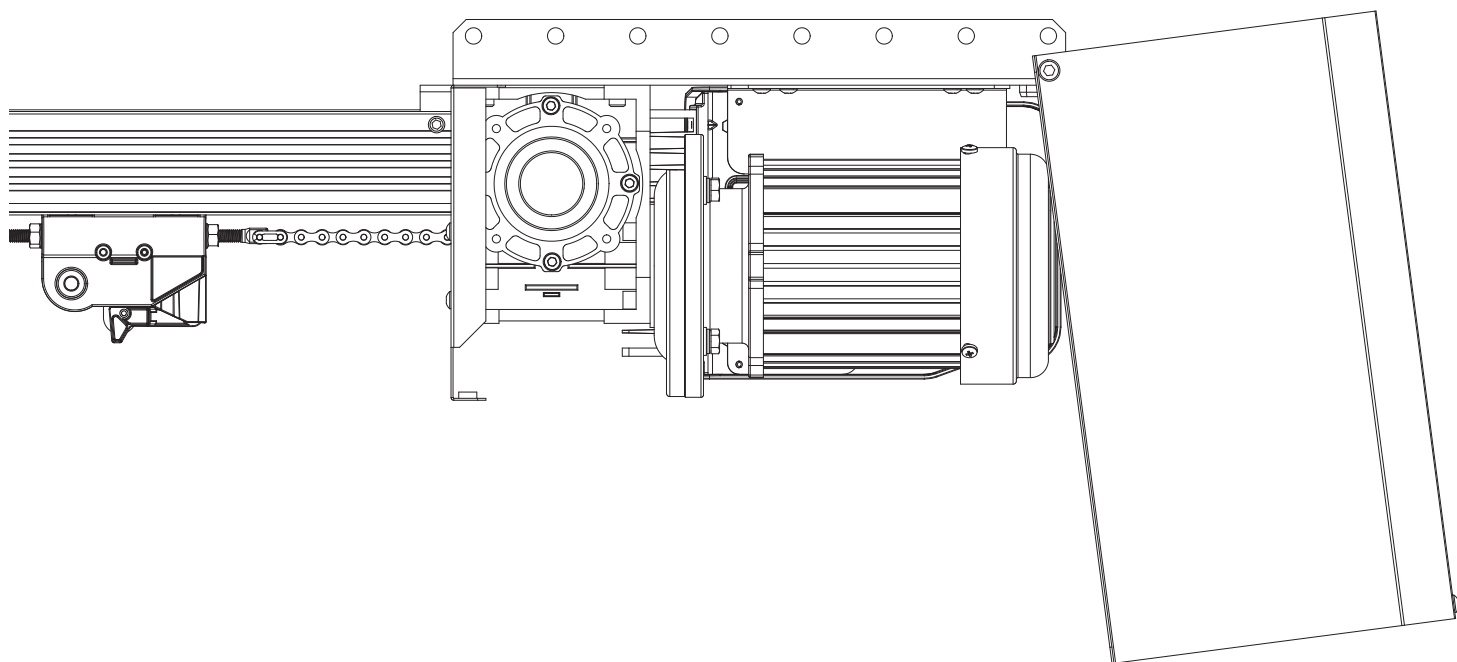

# Axess<sup>®</sup> Pro 1505

Industrial Overhead Door Opener



Featuring **TrioCode™ 128** Technology

automatic  
TECHNOLOGY

# Axess® Pro 1505

## Industrial Overhead Door Opener

### Contents

<b>1. Important Safety Instructions</b>	<b>4</b>
<b>2. Controller Input And Outputs</b>	<b>5</b>
<b>3. Operating Controls</b>	<b>6</b>
<b>4. Kit Contents</b>	<b>7</b>
<b>5. Pre-Installation</b>	<b>8</b>
5.1 Initial Check	8
5.2 Drive Unit Pre-assembly	8
<b>6. Installation</b>	<b>9</b>
<b>7. Programming The Opener</b>	<b>10</b>
<b>8. Setting Limits via Console</b>	<b>11</b>
<b>9. Setting Limits via Transmitter</b>	<b>12</b>
9.1 Code A Transmitter For Limit Setting	12
9.2 Storing Transmitter Code	12
9.3 Navigating To "Set Door Travel Menu"	12
9.4 Setting Limits Via Transmitter	12
9.5 To Recalculate Travel Times	12
<b>10. Coding Transmitter</b>	<b>13</b>
10.1 Coding Transmitter Button	13
10.2 Selecting Function Of The Button	13
10.3 Returning To Main Screen	13
<b>11. Remotely Coding Transmitters</b>	<b>14</b>
11.1 Selecting The Function To Be Coded	14
11.2 Activate Remote Code Set Mode	14
<b>12. Setting Pedestrian Position</b>	<b>14</b>
12.1 Setting Pedestrian Position	14
12.2 Checking Pedestrian Position	14
12.3 Error Displays	14
<b>13. Auto-Close Mode for Console</b>	<b>15</b>
13.1 Safety Close Mode	15
13.2 Setting Up Standard Auto-Close Mode	15
13.3 Safety Beam Triggered Auto Close	15
13.4 Pedestrian Auto-Close	15
13.5 Auto-Close After Obstruction:	15
<b>14. Time Clock</b>	<b>16</b>
14.1 Time Clock Operation	16
14.2 Time Clock Settings	16
14.3 Day Light Saving Time Adjustment	17
<b>15. Battery Replacement</b>	<b>17</b>
<b>16. Battery Disposal</b>	<b>17</b>
<b>17. Accessories Installation</b>	<b>18</b>



# Axess® Pro 1505

## Industrial Overhead Door Opener

<b>18. Specifications</b>	<b>18</b>
<b>19. Troubleshooting</b>	<b>19</b>
<b>20. Maintenance</b>	<b>20</b>
20.1 Door Maintenance	20
20.2 Lubrication (every 3 - 6 months)	20
20.3 Door Service and Repair	20
20.4 Opener Maintenance	20
20.5 Service Indicator	20
<b>21. Appendix</b>	<b>21</b>
A - Console Menu Structure	21
B - Viewing & Editing Logic Console Parameters	24
C - Control Board Adjustments	25
D - Diagnostic Tools	27
E - Memory Tools	28
F - Transmitter Editing	29
G - Transmitter Management	31
<b>Warranty and Exclusion of Liability</b>	<b>32</b>



**WARNING:** Electrical wiring must be in compliance with your local building and electrical codes.

**WARNING:** It is vital for the safety of persons to follow all instructions. Failure to comply with the installation instructions and the safety warnings may result in serious personal injury and/or property and remote control opener damage. Please save these instructions for future reference.

**NOTE:** For full automatic operation a Safety Beam (Photo Electric Beam Sensor) must be fitted to the logic console with this opener. Failure to comply will void the warranty and may cause serious personal injury and/or property damage.

Automatic Technology (Australia) Pty Ltd to the extent that such may be lawfully excluded hereby expressly disclaims all conditions or warranties, statutory or otherwise which may be implied by laws as conditions or warranties of purchase of an Automatic Technology (Australia) Pty Ltd industrial roller Door opener. Automatic Technology (Australia) Pty Ltd hereby further expressly excludes all or any liability for any injury, damage, cost, expense or claim whatsoever suffered by any person as a result whether directly or indirectly from failure to install the Automatic Technology (Australia) industrial roller Door opener in accordance with these installation instructions.

# 1. Important Safety Instructions

The safety alert symbols below indicate a personal safety or property damage instruction exists. **READ THESE INSTRUCTIONS CAREFULLY.**

This automatic Door opener is designed and tested to offer safe service provided it is installed and operated in strict accordance with the following safety rules. Failure to comply with the following instructions may result in death, serious personal injury or property damage.



## WARNING!

- The Door may operate unexpectedly, therefore do not allow anything to stay in the path of the door.
- For **Safety** protection, a Safety Beam **must** be fitted with logic console. Failure to comply will void the warranty and may result in serious personal injury and/or property damage .
- The drive must not be used with a Door incorporating a wicket door, unless the drive cannot be operated with the wicket door open.
- The drive is intended to be installed at least 2.5m above the floor.
- **DO NOT** allow children to operate the opener. Any device that can operate the opener, make sure it is out of reach of children and that the doorway is in full view at all times. Serious personal injury and/or property damage can result from failure to follow this warning.
- When using auto close mode, a **Safety (Photo Electric) Beam** must be fitted correctly and tested for operation at regular intervals. **Extreme caution** is recommended when using auto close mode. **All safety rules** must be followed.



## ELECTROCUTION!

- Place opener in protected area so that it does not get wet.
- Do not spray with water .
- **Disconnect the power cord** from mains power before making any repairs or removing covers. Only **experienced** service personnel should remove covers from the opener.
- If the power supply cord is damaged, it **must** be replaced by an Automatic Technology service agent or suitably qualified person.
- Electrical wiring must be compliance with the local building an electrical codes.



## CAUTION:

Emergency access

Entrapment under operating door

Installation

Security

Entanglement in moving door

- If your facility has no pedestrian entrance door, an emergency access device should be installed.
- **DO NOT** operate the opener unless the Door is in full view and free from objects such as cars and children/people. Make sure that the Door has finished moving before entering or leaving the premises.
- Do not allow children to play with Door controls or transmitters.
- Ensure the Door is in good working order by undertaking regular servicing.
- For **ADDITIONAL SAFETY** protection we **STRONGLY** recommend the fitting of a Safety (Photo Electric) Beam.
- Safety beams must be installed if the closing force at the bottom edge of the door exceeds 400N (40kg)
- Frequently examine the installation, in particular, springs and mountings for signs of wear, damage or imbalance. **DO NOT** use if repair or adjustment is needed since a fault in the installation or an incorrectly balanced Door may cause injury. **DO NOT** attempt to repair the Door yourself as hardware is under extreme tension.
- The Door must be well balanced and in good working order. Door springs, brackets and their hardware are under extreme tension and can cause serious personal injury. Do not attempt to adjust them. A faulty Door must be repaired by a industrial roller Door professional prior to opener installation.
- **Remove or disengage** all Door locks and mechanisms prior to installation of the opener.
- Ensure no parts of the Door or installation extend over public paths or roads.
- After installation a full function **test of the system** and safety devices **must** be done.
- Make sure the Door is fully closed before leaving the driveway. .
- Keep hands and loose clothing clear of Door and opener at all times.



## TWO PERSON LIFT:

- This product requires a two person lift to mount on most doors. Use proper techniques and equipment to raise the unit above the door to suit the site.

# 2. Controller Input And Outputs

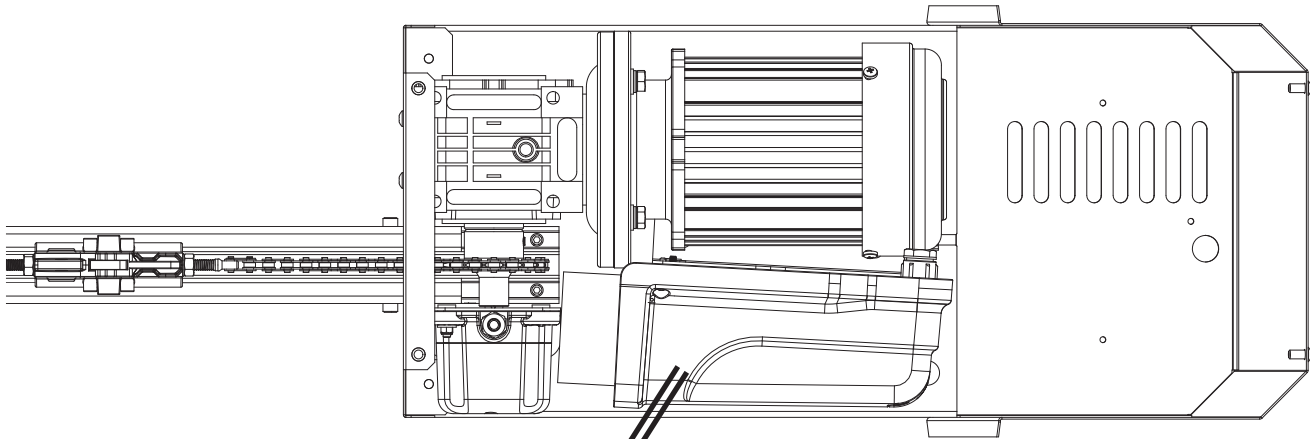
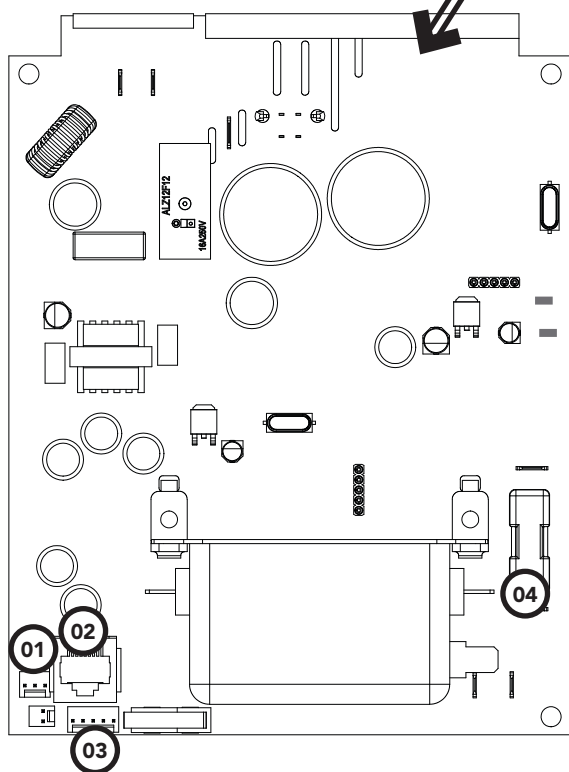
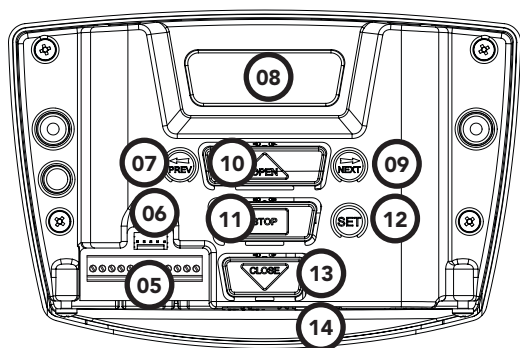

Fig 2.1



- 01 Motor identification harness connector
- 02 Serial interface connector
- 03 Position sensor connector
- 04 10 Amps slow blow mains fuse

# 3. Operating Controls



**Fig 3.1 - Logic Console**

**05** Terminal Block ( From Left To Right )

**V2 Console:**

<b>AUX OUT</b>	<b>Receiver's Auxiliary Output</b>
<b>V+</b>	<b>Accessory Supply</b>
<b>SB3</b>	<b>Third Safety Beam Input</b>
<b>SB2</b>	<b>Second Safety Beam Input</b>
<b>SB1</b>	<b>First Safety Beam Input</b>
<b>0V</b>	<b>Common For Safety Beams</b>
<b>0V</b>	<b>Common Terminal For Control Inputs</b>
<b>FIRE</b>	<b>N/O , N/C Input Terminal</b>
<b>GPI</b>	<b>N/O Input Terminal</b>
<b>OPN</b>	<b>N/O , N/C Input Terminal</b>
<b>STP</b>	<b>N/O , N/C Input Terminal</b>
<b>CLS</b>	<b>N/O Input Terminal</b>

**06** Programmer PG-3 Input

**07** Console Previous Button

**08** Liquid Crystal Display

**09** Console Next Button

**10** Console Open Button

**11** Console Stop Button

**12** Console Set Button

**13** Console Close Button

**14** RJ45 Connector

# 4. Kit Contents

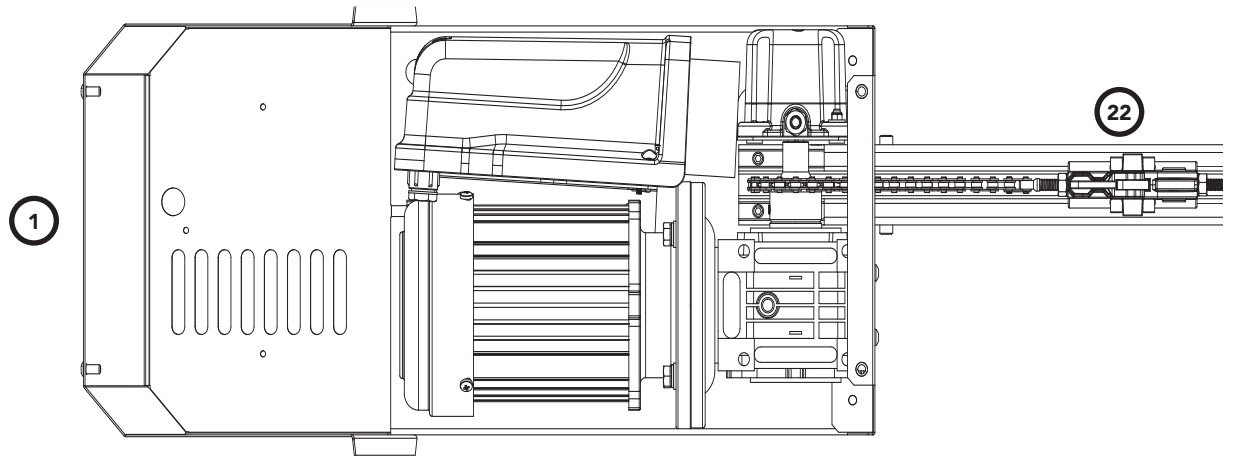
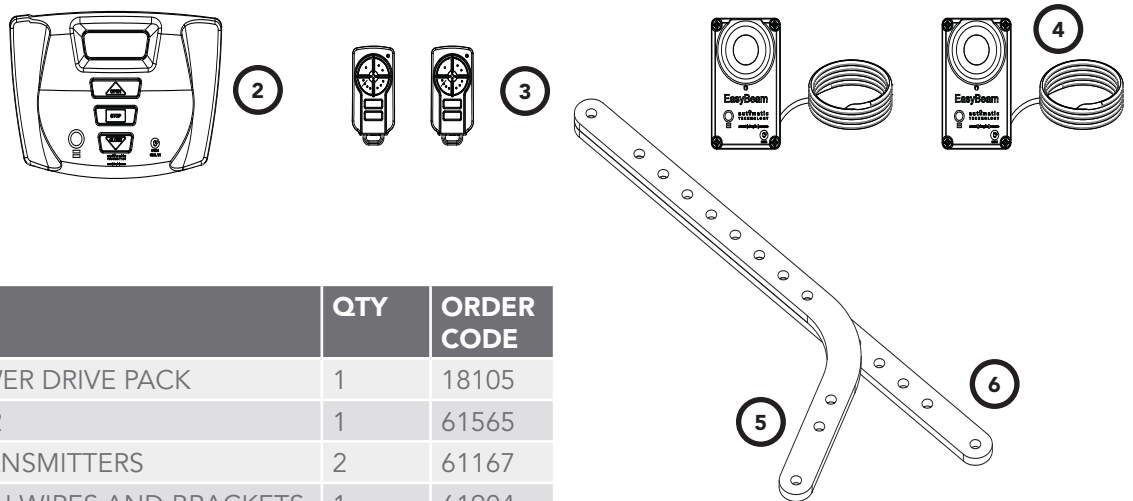

Fig 4.1



ITEM	DESCRIPTION	QTY	ORDER CODE
1	AXESS 1505 V1 POWER DRIVE PACK	1	18105
2	LOGIC CONSOLE V2	1	61565
3	PTX-5V2 TC-128 TRANSMITTERS	2	61167
4	SAFETY BEAMS WITH WIRES AND BRACKETS	1	61904
5	BENT ARM	1	62800
6	STRAIGHT ARM	1	62790

### ACCESSORY PACK

7	NILOCK NUT M8	1	10860
8	WALL BRACKET	1	62525
9	HEX HEAD SCREW M8 X 70	1	10088
10	SLEEVE 081246	1	64385
11	DOOR BRACKET LOCATOR	1	62515
12	DOOR BRACKET	1	62511
13	PIN SNAP SSP 8 ZNU 31080	2	10720
14	HEX HEAD SCREW M8 X 25	2	10110
15	CLEVIS PIN 0829	2	62551
16	HEX SERRATION FLANGE NUT M8	2	10148
17	SPACE HEAD CAP SCREW M5 X 45	2	10008
18	SPACE HEAD CAP SCREW M6 X 12	2	10010

### RAIL

22	4M RAIL	1	92509
----	---------	---	-------

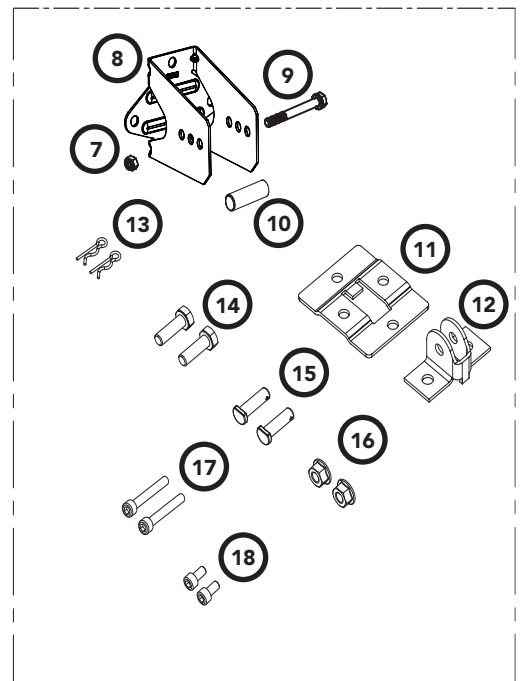

# 5. Pre-Installation



## IMPORTANT SAFETY INSTRUCTIONS FOR INSTALLATION

**Warning: Incorrect installation can lead to severe injury.  
Follow ALL installation instructions.**

The Axess® Pro 1505 is designed to operate most commercial and heavy residential overhead doors.

### 5.1 Initial Check

Before commencing installation, check the following:

- The door is in good working condition and moves freely for the full travel in both directions.
- The mounting must be a solid construction (concrete, brick, wood or steel) and must be able to withstand the full driving force applied to the door (2kN).
- There is a 240V 10 Amp power point located within one metre of the drive unit.
- Safety Beams have been installed. The Safety Beams should be positioned as close to the door as practicable.

### 5.2 Drive Unit Pre-assembly

The drive unit (1) and track are supplied as two separate packages. The drive sprocket is part of drive unit.

- To connect rail (22) to the drive unit, open the cover by removing screws.
- Cut the cable tie that holds the chain index together on the track.
- Wrap the chain around the hub on the sprocket on the drive unit.
- Pull the chain towards you approx. 0.5m.
- Run the chain around the sprocket.
- Slide rail into the opener and align holes.
- Secure the rail to drive unit with the two (2) M5 x 45 Space Head Cap Screws (17) and two (2) M6 x 12 Space Head Cap Screws (18) using an allen key as shown in **Fig 5.1**.
- Pull the other end of the chain to connect the chain index.
- Turn the index and tension the chain.
- Close the cover to the drive unit.

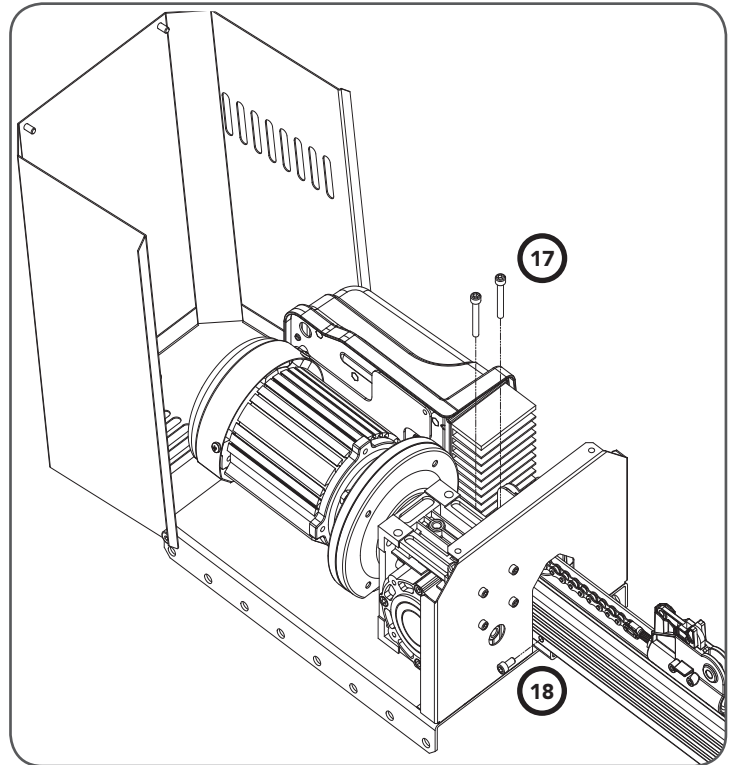

**Fig 5.1**



# 6. Installation



**THIS PRODUCT REQUIRES A TWO PERSON LIFT TO MOUNT ON MOST DOORS**  
- use proper lifting techniques and equipment to suit the site.

## 6.1 Mounting The Drive Unit

- Determine the centre of the door and mark this point on the wall above (**Fig. 6.1**).
- Raise the door to the open position.
- Measure 50mm above the top of the door (at the door's highest point) and mark this position (**Fig. 6.2**).
- Mark the position of the wall bracket (8) holes on the wall above the door (**Fig. 6.3**). Check the bottom of the bracket is a minimum of 50mm above the top of the door when in the open position.
- Secure the wall bracket (8) in place with loxins or appropriate fasteners (not supplied).

**NOTE:** The supporting structure where the bracket is mounted, must be capable of supporting 2kN push / pull force.

- Measure 4080mm (+/- 150mm) across the ceiling from the wall centre point (**Fig. 6.2**). Install perforated angle or similar (not supplied).
- Turnover the drive unit (1) and pull the ring located at (Y) to release the vent (**Fig. 6.4**).
- Raise the opener into position using suitable equipment for the height of the door.

**NOTE:** The drive unit weighs over 25kg and therefore may require 2 persons to mount into position.

- Connect the rail (22) to the wall bracket (8) and mount the opener to the perforated angle.

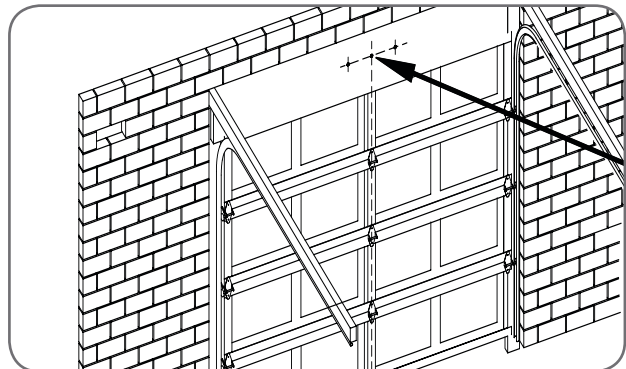

Fig 6.1

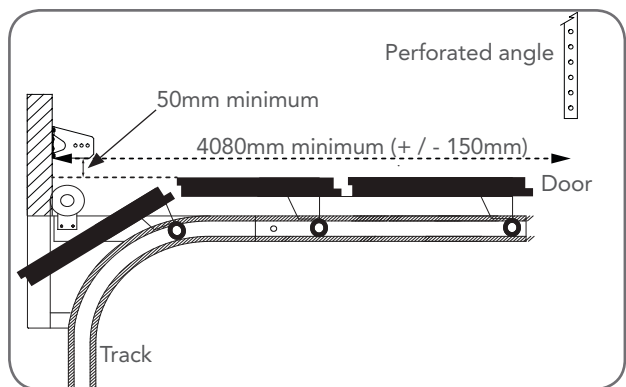

Fig 6.2

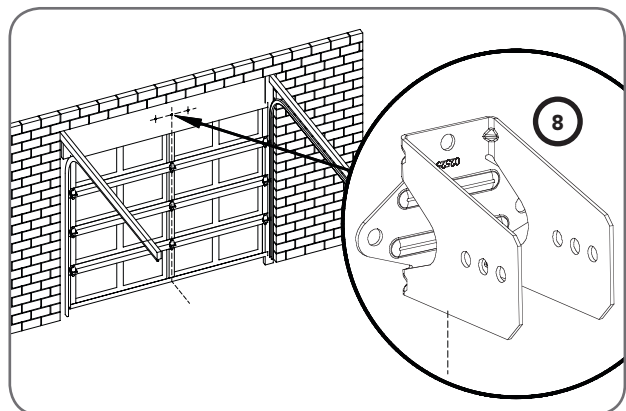

Fig 6.3

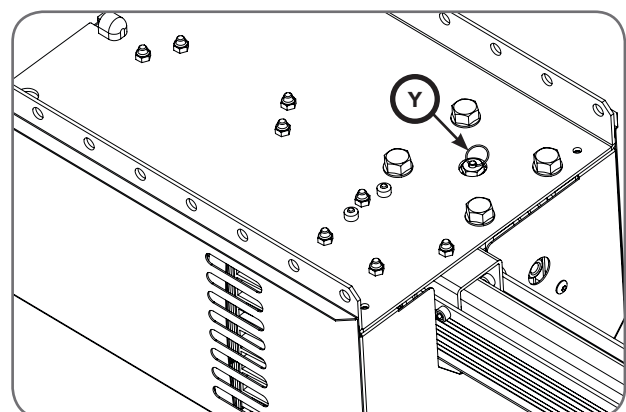
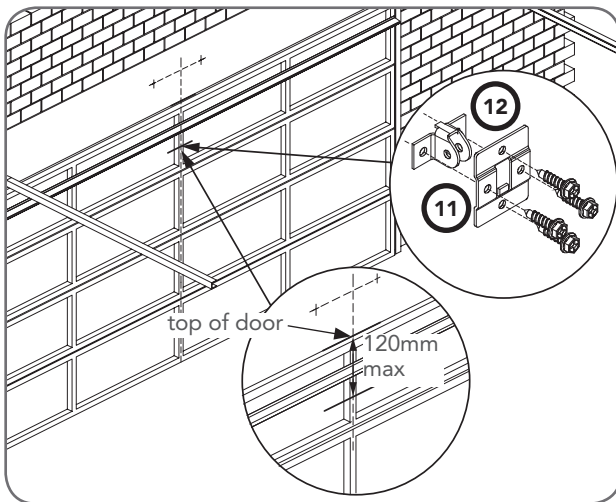

Fig 6.4

# 6. Installation

Fig 6.5



j. The door bracket comes in two parts. The door bracket locator (11) is placed over the door bracket (12) and uses 4 mounting holes for extra strength. Mount the door bracket to the centre line of the door (Fig. 6.5), using M6 or equivalent screws (not supplied).

**NOTE:** If in doubt about the strength of the door, reinforcement may need to be added to the frame or panel where necessary. Damage to the door panel may occur if the bracket is installed incorrectly on a panel with insufficient strength. The door opener warranty does not cover damage caused by the opener to the door and/or door panel.

k. Assemble the bent (5) and straight arm (6) with two (2) M8 x 25 Hex Head Screw (14) and two (2) M8 Hex Serration Flange Nut (16) (Fig. 6.6).

l. Connect the assembled arm to the door bracket (12) and the trolley by a clevis pin (15) and a pin snap (13).

Fig 6.6

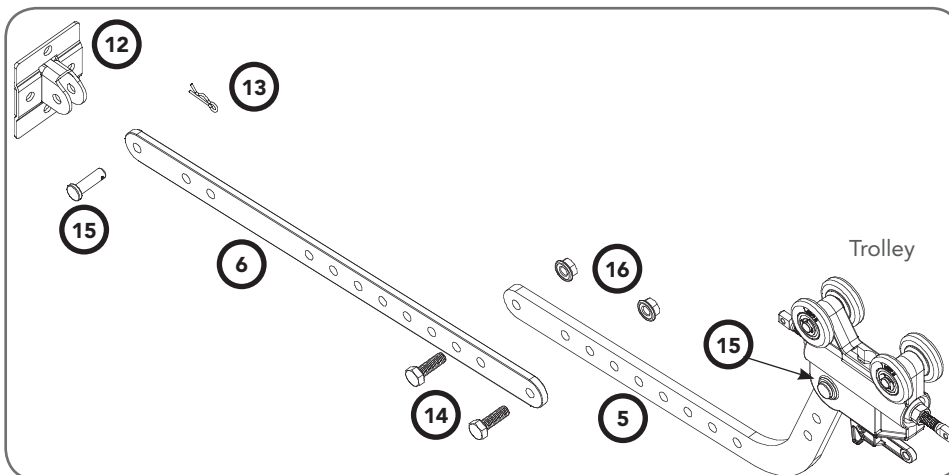

**NOTE:** The shuttle must be in disengage position. Always use both the bent & straight arms. If installing on a door with bad wave action, lengthening the arm even further will assist the door operation by reducing the wave action.

# 7. Programming The Opener

The process for an automated program is as follows;

Program	Menu's required	Function	Section
Automated Full Logic Set Up with Safety Beams	Menu 10.1	Setting the Limits	8.1 or 9.4
	Menu 1	Coding the Transmitter	10.1
	Menu 6.1	Safety Close Mode	13.1
	Menu 3	Auto Close Times	13.2 to 13.5

When Safety Beams are not installed, the controller will display the following message;



**ATTENTION! No Safety Beams have been detected. "Safety Close" mode has been turned on. See Manual for details. Press SET to continue.**

**NOTE:** Fitting Safety Beams enables the Auto-Close feature to become active.



**HELPFUL TIP: Install Safety Beams by following the Safety Beam Manual for wiring details to L2 Consoles.**

# 8. Setting Limits via Console

## 8.1 Setting Travel Limits with Logic Console

- a. Turn on the power to the opener. The controller will go through a start up sequence.
- b. After a short delay the MAIN SCREEN (Fig. 8.1) will be displayed. If this is the first time the Axess® Pro 1505 is being used, the MAIN SCREEN should enter into limit set mode and the blue close LED will be flashing. If the display shows that an input is active, then rectify the situation before continuing with the procedure for setting the travel limits. Press and hold the CLOSE button - the Door should start closing.
  - i. If the Door opens, release the CLOSE button and press the STOP button once to change the motor's direction. Press and hold the CLOSE button until close position of the Door is reached.
  - ii. If the Door overshoots, press the OPEN button to move the Door in the open direction.
- c. When the Door is at the desired close position, press the SET button to record the close limit position. The display will change and the green open LED will start to flash (Fig. 8.2).
- d. Press and hold the OPEN button to open the Door. When the Door is at the desired open position, release the OPEN button
  - i. If the Door overshoots, press the CLOSE button to move the Door in the CLOSE direction.



**WARNING! Once the next step is performed, the Door will automatically close and open to calculate travel time settings. Keep persons and objects clear of the Door.**

- e. Press the SET button to store the open limit. The Door will now automatically close and open to calculate the travel time settings. After this, If PE Beams are installed, the opener can be operated with the OPEN or CLOSE button on the logic console or from the transmitter. Otherwise, the controller will be loaded with "Safety Close Mode". (Section 13.1)

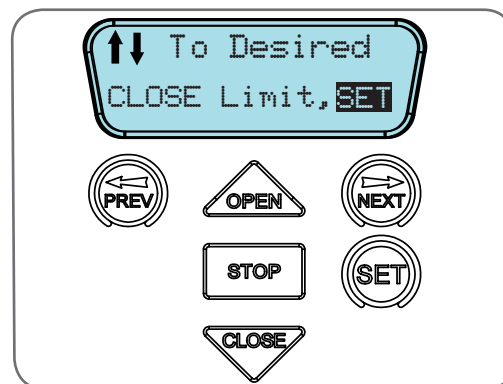

Fig 8.1

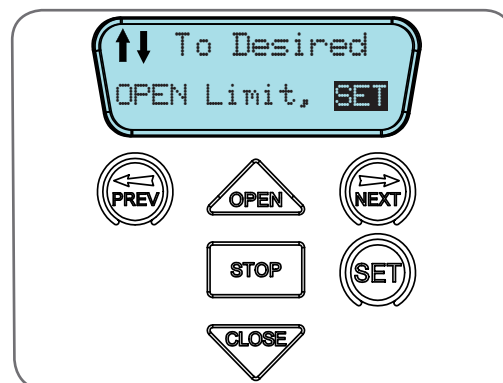

Fig 8.2

# 9. Setting Limits via Transmitter

In order to use a transmitter to set the limits, it must first have at least one of its buttons coded to the logic console. The function assigned to the transmitter's buttons is of no concern here as the buttons are temporarily assigned to OPEN, CLOSE and SET (Fig. 9.2).

## 9.1 Code A Transmitter For Limit Setting

- Press NEXT to navigate to Menu 1.
- Press SET to enter the code set procedure (Fig. 9.1).

## 9.2 Storing Transmitter Code

- The logic console will prompt to press one of the transmitter's button.
- Press the transmitter button you wish to use to operate the opener (e.g. button 1).
- Press the same transmitter button again as prompted by the display.
- Press the SET button to store the transmitter.

## 9.3 Navigating To "Set Door Travel Menu"

- Press PREV to navigate to Menu 10.
- Press SET to display MENU 10.1.
- Press SET two times to enter the limit setting procedure. The close blue LED will start to flash.

## 9.4 Setting Limits Via Transmitter

- Press and hold Button 4 on the transmitter to close the Door.
  - If the Door opens, release button 4 and press the STOP button once on the logic console to change the direction of the motor. Then press and hold Button 4 on the transmitter to close the Door.
  - If the Door is closed too far, press Button 1 to "inch" the Door towards open.
- When happy with the close limit position, press Button 2 to store this in the memory. The open green LED will start to flash. Press Button 1 to open the Door.
  - If the Door is opened too far, press Button 4 to "inch" the Door closed.

**WARNING: The Door will automatically close and open once the next step is performed. Ensure that no persons or objects are in the path of the Door.**

- When you are happy with the open limit position, press Button 2 on the transmitter to store into memory. The Door will now automatically close and open to calculate the travel times and other settings.
- After this, if PE Beams are installed, then the opener can be operated with the OPEN or CLOSE button on the logic console or from the transmitter. Otherwise, the controller will be loaded with "Safety Close Mode". (Section 13.1)

## 9.5 To Recalculate Travel Times

Reprofiling is a simplified way of re-learning the travel characteristic of a previously setup Limit Switch travel installation. Re-profiling can be used when the travel characteristics of the Door change due to mechanical adjustments etc.

- To initiate a re-profile, locate "MENU 10.2 Reprofile Travel"
- Press SET and follow the prompts.

The Door will start to move and re-calculate force margins. The Door can move between the open and close limit positions up to two (2) times (depending on the position of the Door and the power up condition). A single beep will be heard once the process is complete.

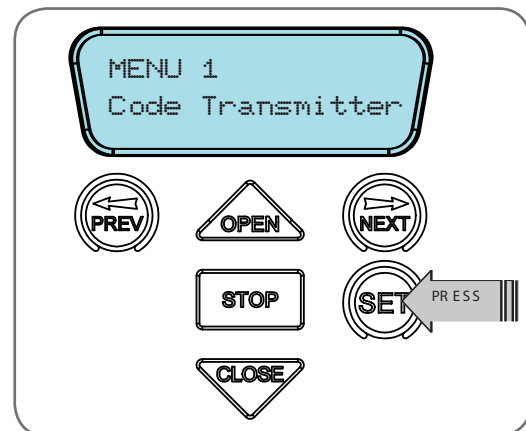

Fig 9.1

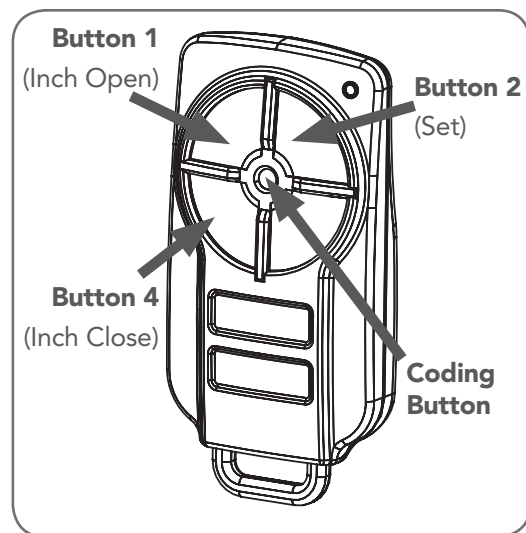

Fig 9.2

**IMPORTANT NOTE:**  
Only TrioCode™128 Technology Transmitters are compatible with the Axess® Pro 1505 product.

# 10. Coding Transmitter

The Axess® Pro 1505 can store 511 transmitters in its memory. Each transmitter can be allocated an alpha-numeric ID label up to eleven characters in length and each button can be assigned to one of several control functions. The settings for a transmitter are represented in **Fig. 10.1**. It shows the transmitter's store number, ID label or serial number and the functions assigned to each of the four buttons. To toggle between ID/SN display, press UP/DOWN with the cursor on the ID/SN indicator. The procedures below code, delete, replace, edit and copy transmitter records.

**IMPORTANT NOTE:**  
Only TrioCode™128 Technology Transmitters are compatible with the Axess® Pro 1505 product.

## 10.1 Coding Transmitter Button

### Navigating To Menu 1 "Code Transmitter"

- Press NEXT to navigate to Menu 1).
- Press SET to enter the code set procedure.

### Storing Transmitter Code

- The logic console will prompt to press one of the transmitter's buttons.
- Press the transmitter button you wish to use to operate the opener (e.g. button 1) (**Fig. 10.2**).
- Press the same transmitter button again as prompted by the display.

## 10.2 Selecting Function Of The Button

The logic console will now show the transmitter's record, with a cursor on the field for the button being coded (**Fig. 10.3**). Use OPEN/CLOSE to select the function for the button.

### Available functions:

OSC (Open/Stop/Close)	PED (Pedestrian access)
SWP (Swipe)	CLS (Close)
OPN (Open)	STP (Stop)
LGT (Courtesy Light)	VAC (Vacation Mode)
AUX (Auxiliary )	OFF (No action)

**NOTE:** OSC can change to OS and CLS (Close) function, but is not available in the case where PE Beams are not installed. Press SET to save the settings or STOP to abort without saving.

## 10.3 Returning To Main Screen

Press STOP to return to the MAIN SCREEN and test the transmitter.

**NOTE:** To edit the other settings, refer to transmitter edit procedure in Appendix F.

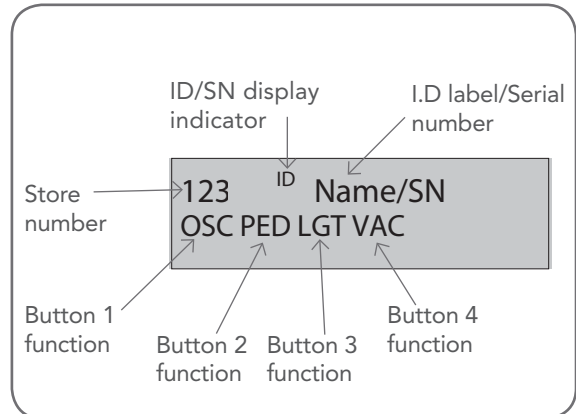

Fig 10.1

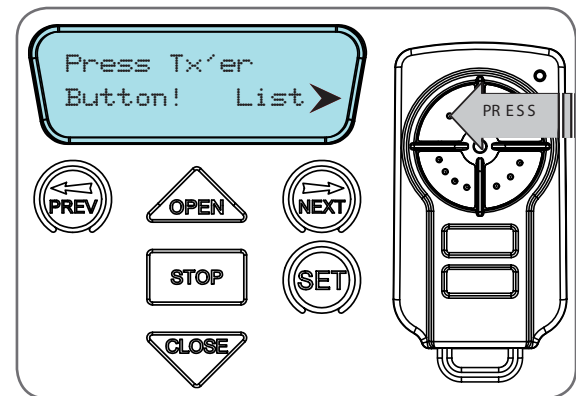

Fig 10.2

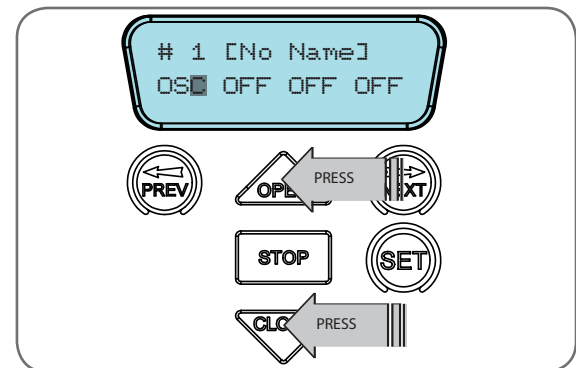

Fig 10.3

# 11. Remotely Coding Transmitters

If a transmitter is already coded into the opener, additional transmitters can be coded without being in direct contact with the opener's wall console unit.

**NOTE:** Only the function of the existing transmitter button can be assigned to new transmitter. Please read instructions prior to proceeding - there is a time-out facility for security reasons.

## 11.1 Selecting The Function To Be Coded

- Using the existing transmitter, operate the Door with the transmitter button which has the function to be coded (e.g. Button 1 has been coded with the OSC function assigned).
- If the button's function activates the Door (PED, SWP, OSC, CLS, STP or OPN) wait for the Door to complete its cycle.

## 11.2 Activate Remote Code Set Mode

- Use a small pin / pen to press and hold through the Coding Hole of the existing transmitter for 2 seconds (**Fig. 11.1**).
- Within 10 seconds, press the button on the new transmitter you wish to code for 2 seconds (**Fig. 11.2**).
- Press the same button again (within 10 seconds) for confirmation.
- Test Operation. The new transmitter button should now function as the existing transmitter.

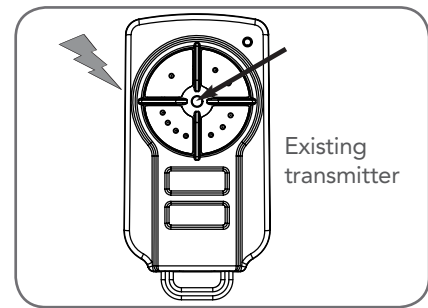

Existing transmitter

Fig 11.1

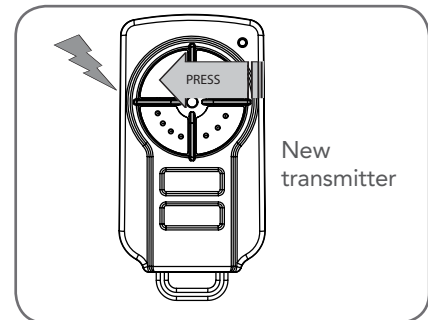

New transmitter

Fig 11.2

**NOTE:** When a transmitter is remotely coded, its ID label is set to that of the existing transmitter. If the existing transmitter does not have an ID label assigned, then the ID label of the new transmitter is set to: R/C Tx ###, where ### is the existing transmitters store number. This ensures that the originator of any remotely coded transmitter can be identified.

**NOTE:** To Manage your Transmitters, refer to Transmitter Management in Appendix G.

# 12. Setting Pedestrian Position

After completing the limit setup procedure the Pedestrian Access position is automatically set to a position which is approximately in the middle of the door travel. The position can be manually set by following the Setting Pedestrian Position procedure.

## 12.1 Setting Pedestrian Position

- Drive and stop the door at the desired Pedestrian Access position by using a transmitter or wall control unit.
- Press PREV to navigate to Menu 10.
- Press SET. MENU 10.1 will be displayed.
- Press NEXT to go to MENU 10.3
- Press SET on the wall control unit to save the Pedestrian Access position (**Fig. 12.1**).
- Press the STOP button to exit to the main screen.

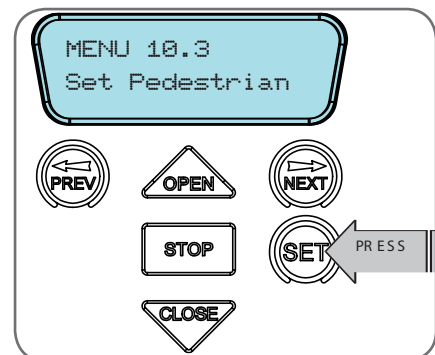

Fig 12.1

## 12.2 Checking Pedestrian Position

When activated by a transmitter button which is coded as Ped mode, the opener drives the door to the preset position from either above or below. Ped Mode's active status is indicated on the display (**Fig. 12.2**). If a Ped Mode button is pressed while the door is moving, the door will stop. If a Ped Mode button is pressed when the door is in the Ped position, then the door will close.

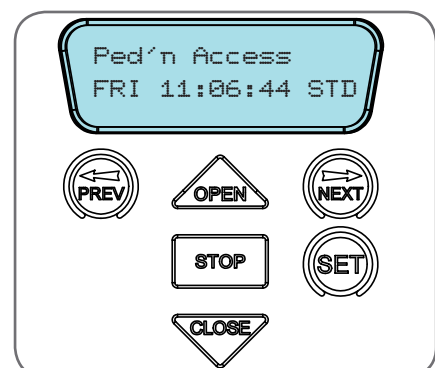

Fig 12.2

## 12.3 Error Displays

During the above procedure many error checks are performed. If an error is detected, a message will be displayed indicating the error.



# 13. Auto-Close Mode for Console

## 13.1 Safety Close Mode

The controller has a built in Safety Beam detection. If Safety Beams are not installed, the controller will automatically turn on the Safety Close Mode. By enabling this parameter, the Door can only be closed by holding the close button on the wall control unit.

In order to facilitate an Automated Set Up and enable to Door to be closed by a transmitter proceed by;

Navigate to "Safety Close Mode (Menu 6.1)"

- a. Press the OPEN button.
- b. Warning will display.



**DANGER! Read Manual before turning off Safety Close Mode. Press SET to continue.**

- c. Press SET to accept the warning.
- d. Press either the OPEN or CLOSE arrows to change to OFF.
- e. Press SET to Save the change.



**WARNING! The Auto-Close function is not available unless Safety Beam is installed.**

## 13.2 Setting Up Standard Auto-Close Mode

Menu 3. Auto-Close Times

The Auto-Close modes automatically close the Door after it has been operated. To implement this the controller starts a timer once the Door has reached its desired open position. The timer then counts down and when it expires the controller starts to close the Door. Details about the four Auto-Close modes follow. Automatic Technology strongly recommend using a Safety Beam for added safety.

Menu 3.1 Standard Auto Close

This mode is selected by entering a non-zero time for the STD Auto-Close parameter. When selected, the Door will Auto-Close after being fully opened (except when the Door has reversed to the open position after a motor obstruction or overload. Countdown is suspended by: S.B., OPN or SWP input being active. The countdown is aborted if the STP input is activated. If the Door is already open and the OPN or the SWP input is activated, then the countdown will start.

## 13.3 Safety Beam Triggered Auto Close

Menu 3.2 (SB AC Trig)

This mode is selected by entering a non-zero time for the "Safety Beam Auto-Close" parameter. This mode is used to Auto-Close the Door but only after an object has passed through the doorway and has triggered the Safety Beam input. Any Safety Beam or combination of Safety Beams can be configured to activate Safety Beam Auto-Close mode and combinations are:

One Beam only

- i. Safety Beam 1
- ii. Safety Beam 2
- iii. Safety Beam 3

Either Beam

- i. Safety Beam 1 or Safety Beam 2
- ii. Safety Beam 1 or Safety Beam 3
- iii. Safety Beam 2 or Safety Beam 3
- iv. Safety Beam 1 or Safety Beam 2 or Safety Beam 3

Combination

- i. Safety Beam 1 and Safety Beam 2
- ii. Safety Beam 1 and Safety Beam 3
- iii. Safety Beam 2 and Safety Beam 3
- iv. Safety Beam 1, Safety Beam 2 and Safety Beam 3

**NOTE:** The swipe input can be used to clear the Safety Beam triggered status so that the Safety Beam input must be activated again before the countdown will start. As with the other Safety Beam modes, the STP input will abort countdown and the OPN and SWP inputs will restart the countdown if the Door is OPEN.

Menu 3.3 Directional Auto-Close (SB Auto Close)

This mode is selected by entering a non-zero time for the "S.B. Auto-Close" parameter. S.B 3 Beam must be installed and configured to EXIT WITH SB1. Sub in menu 6.5. This mode is used to Auto-Close the Door only after a vehicle has passed through the Safety Beam 3 and then through Safety Beam 1 to exit the premises. This mode is useful for fire brigade, ambulance stations etc.

## 13.4 Pedestrian Auto-Close

Menu 3.4 Pedestrian Auto-Close

This mode is selected by entering a non-zero time for the "Ped'n A/C" parameter. When selected, the door will Auto-Close after being opened for pedestrian access unless it was following a reverse from an obstruction.

Menu 3.5 (Safety Beam) Pedestrian Triggered Auto-Close

Any Safety Beam or combination of Safety Beams can be configured to activate Safety Beam Auto-Close mode.

Menu 3.6 (Safety Beam) Pedestrian Auto-Close

This mode is selected by entering a non-zero time for the "Ped'n A/C" parameter. When selected, the door will Auto-Close after being opened for pedestrian access unless it was following a reverse from an obstruction.

## 13.5 Auto-Close After Obstruction:

Three parameters are provided to enable the Auto-Close feature to be activated after obstructions and power up. Normally the Auto-Close feature is not enabled after obstructions for safety reasons. Safety Beams must be used for these features to be activated. The three parameters are:

Menu 3.7 (Auto-Close after close overload)

This mode enables the Auto-Close feature to be activated when a close overload occurs (requires Safety Beams).

Menu 3.8 (Auto-Close after open overload)

This mode enables the Auto-Close feature to be activated when an open overload occurs.

Menu 3.9 (Auto-Close after power up)

This mode enables Auto-Close feature after power up.



# 14. Time Clock

The opener provides a programmable time clock which can be used to control the Axess® Pro 1505 on a timed basis at various times of the week. This section details the time clock operation and configuration.

## 14.1 Time Clock Operation

The time clock consists of a 7 day clock and storage for 32 programs. The clock is powered by its own battery and therefore does not lose time when the Axess® Pro 1505 is turned off. Each time clock program defines the time of the day and the days of the week it is to run and the output function to be executed. Any combination of the days of the week can be selected.

## 14.2 Time Clock Settings

The Time Clock settings are accessed by selecting the Time Clock menu (MENU 7). Press SET (Fig. 14.1) to enter the menu and then PREV or NEXT to navigate through the options.

### Menu 7.1 Set Time/date

This is where the current time, date and day are displayed and set (Fig. 14.2).

**NOTE:** The time is in a 24 hour format and the Day of the week is not automatically set with the date. To change the settings simply press UP or DOWN to display the cursor and then move to the field to be changed using the NEXT / PREV buttons. Then press OPEN/CLOSE to change the setting and then the SET or STOP buttons to save.

### Menu 7.2 View Programs

Select this menu to display or edit the Time Clock programs (Fig. 14.3). When selected, program number 1 is displayed and the cursor is shown on the program number field. The other fields shown include the function, time and days of operation. The example

Fig. 14.4 shows that the DOOR will OPEN at 7 am on Mondays, Tuesdays, Wednesdays, Thursdays and Fridays. Use the OPEN /CLOSE buttons to scroll through the other programs (Fig 14.5).

To edit a program, simply press the NEXT / PREV buttons to move the cursor onto the required field and press the OPEN/CLOSE button to change the value. To save the program settings, press SET or to exit without saving press STOP.

The selectable functions available are:

Function	Operation
<b>RX = Off</b>	From the time when the program with RX = OFF is activated, all the transmitters will be disabled.
<b>RX = On</b>	From the time when program with RX = ON is activated, all the transmitters will be enabled.
<b>Open Door</b>	From the time when the program with OPEN DOOR is activated, the door will open and stay open.
<b>Stop Door</b>	This feature will let the user activate the stop function until the next program starts. The door will not open or close while stop is activated.
<b>Free Door</b>	Release the controls from the timer.
<b>Off</b>	This will temporarily disable the program.

Fig 14.5

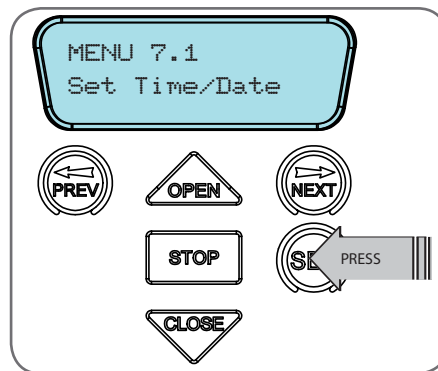

Fig 14.1

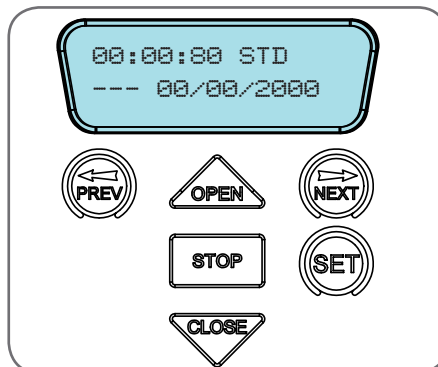

Fig 14.2

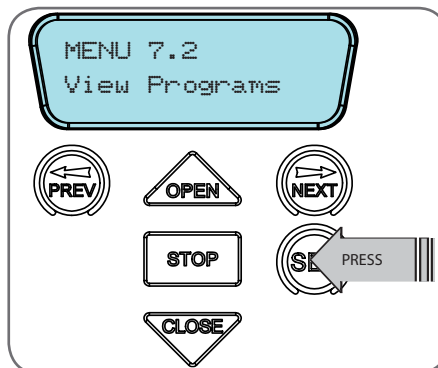

Fig 14.3

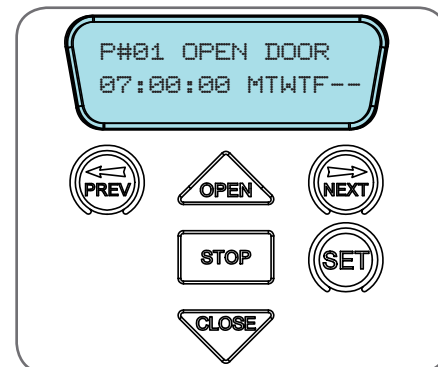

Fig 14.4

**NOTE:** The most recent program that applies to an output remains active until a new program takes effect.

**NOTE:** If a Time Clock program does not have a day selected then it can not be executed. If a Time Clock program is taking control of the opener, then this status is displayed on the LCD. The MAIN SCREEN and clock status screen flashes alternatively.



## Menu 7.3 Settings

Under this menu, three sub menus are available:

- a. Run Programs. The programs of the timer can be interrupted by selecting RUN PROGRAM off.
- b. Configuration Of GPI Input. General Purpose Input can be configured as OSC, PED or DST setup.
- c. This is activated by the GPI input terminal with the N/O switch.
  - i. When GPI Selected As OSC: If the door is moving, the activation of GPI input or pressing a transmitter button with the OSC function assigned will cause the door to stop. The next trigger will move the door in the opposite direction to the last travelled.
  - ii. When GPI Input Is Configured As PED: The activation of the GPI input or by pressing a transmitter button with PED function assigned will open the door partially to allow pedestrian access but prevent vehicle access. The position the door is driven to is automatically set to halfway during setting of the travel limits, but can be adjusted to suit.
  - iii. When GPI Input Is Configured As DST: GPI input can be used to switch between STD time and DST (daylight savings time). The AUX input needs to be constantly active to show day light saving time.

## 14.3 Day Light Saving Time Adjustment

The time selected is the amount of time added to STD time when DST is selected by AUX input. Options are OFF, 30, 60, 90 or 120 minutes.

# 15. Battery Replacement

## 15.1 Removing the Battery From the Transmitter

(Battery Type: 3V Lithium Battery CR2032).

Use a non-metallic object (e.g. pen) to remove the battery. (Fig. 15.1). To test the battery is working, press and hold a transmitter button; (Fig. 15.2).

Light Status	Battery Status
Solid	OK
Flashing	Requires replacement
No light	Requires replacement

Fig 15.2

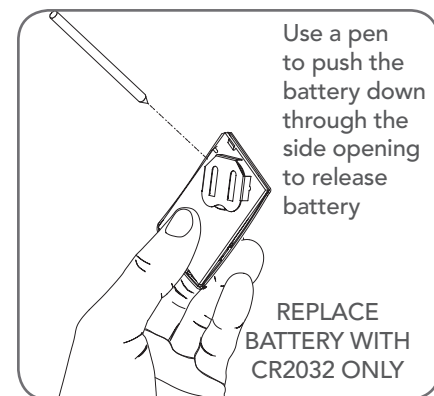

Fig 15.1

# 16. Battery Disposal

When batteries reach the end of their usual life in accordance with Australian Battery Recycling Initiative please follow the next simple steps for protecting the environment.

Refer to the Automatic Technology website for information on where to recycle batteries in Australia.

Recycling all batteries will have other environmental and social benefits:

- Some batteries are less toxic but hazardous for other reasons. Lithium batteries can explode or catch fire in landfill, while button cells are dangerous if swallowed by children. Recycling offers a safe and environmentally responsible solution for end of life batteries.
- Battery recycling recovers non-renewable materials such as lead, cadmium, stella, zinc, manganese, cobalt, silver, plastics and rare earth elements.
- Removal of batteries and other hazardous household products from household waste facilitates the recovery of organic materials through alternative waste technologies such as composting. Batteries and heavy metals are known contaminants in compost.
- The community supports recycling because it reduces waste to landfill and achieves environmental benefits.

 **DO NOT** throw the batteries in municipal waste. This symbol of the crossed out wheeled bin indicates that the battery should not be placed in the municipal waste. Check your local regulations for appropriate disposal of the batteries.

 **WARNING!** Prior to disposal, recycling, or collection, all battery terminals must be securely insulated with a non conductive material to prevent any two batteries from short circuiting and generating heat during storage or transport. Battery terminals may be insulated with electrical tape; or batteries may be individually packaged in a non conductive material (e.g., plastic bag or original packaging).

# 17. Accessories Installation

## 17.1 Fitting Courtesy Lights

A light relay module (optional) can be connected to the aux out on the console to control the courtesy light.



**WARNING: A qualified electrician must perform the installation where 240V AC power is used.**

Menu 4. Light Times

- Press NEXT or PREV on the wall control unit to navigate to Menu 4 Light/Lock Times.
- Press SET to select the sub menu.
- Press NEXT or PREV to navigate through the sub menu.
- Press OPEN to increase or CLOSE to decrease the time.
- Press SET to save the new time.
- Press the STOP button two times to exit.
- Test the light operation.

# 18. Specifications

Technical Specifications	Single Phase	
Power supply	230Va.c. 50Hz	
Motor type	Single Phase 240 Volts (Delta Connection)	
Model	AX1505	
Motor Power	0.373 KW (1/2 HP)	
Track	4m Track	6m Track
Maximum Door Opening	3.5m	5.5m
Maximum Door Size / Area	25m <sup>2</sup>	25m <sup>2</sup>
Duty Cycle	60%	
Receiver type	UHF Multi-frequency FM Receiver	
Receiver code storage capacity	511 X 4 button Transmitter Codes	
Receiver Sensitivity	- 103 dB	
Transmitter frequency	UHF Multi-frequency FM Transmitter	
Coding type	Code hopping	
Number of code combinations	Over 100 billion random codes	
Code generation	Non-linear encryption algorithm	
Controller fuse	10A slow blow	
Transmitter Battery	CR - 2032 (3 Volts)	
Real Time Clock Battery	CR -1220 (1.5 Volts)	

### NOTE:

- If the Safety Beams are not installed then the controller will automatically go into "Safety Close" mode. A limited number of features are available in this mode, please refer to menu 6.1 in Section 13.1.



# 19. Troubleshooting

Symptom	Possible cause	Remedy
Blank display screen.	Mains power not switched on.	Switch on mains power.
	Communication cable not connected.	Connect the communication cable.
	Drive unit cover is loose or missing.	Install / secure drive unit cover.
Logic console displays "Drive Disengaged".	Hand chain is not freely hanging.	Free the hand chain.
During limit setting, pressing the close button causing the door to open.	Motor running in wrong direction.	Change the motor direction by pressing stop button on the logic console once.
Opener Overloads.	Door is locked.	Unlock the door.
	Door tracks/hardware damaged.	Door requires service/repair by qualified technician.
	Full load current settings are too low.	Adjust the full Load current in menu 2.1. (Appendix A & C)
Door operates from logic console (OPEN/CLOSE) button but not from transmitter.	Transmitter code not stored in memory.	Code transmitter into opener's memory. (Section 10.1)
	Transmitters operation disabled from the time clock.	Enable the transmitter operation in the time clock menu. (Section 14.5)
	The opener is in "Vacation Mode".	Turn off "Vacation Mode". (Appendix C Menu 6.16)
	Flat battery in transmitter.	Replace battery (Section 15)
Door does not close with transmitter.	Safety Close Mode is on.	Turn the Safety Close Mode off. (Section 13.1)
	Transmitter does not contain TrioCode™128 Technology	Check that the transmitter has grey buttons and the model number on the back displays V2. Contact dealer for support if otherwise.
	Safety Beams not installed or not working properly.	Make sure Safety Beams are operational.
Door will not close fully.	Door limit positions need to be reset.	Reset limit positions. (Section 10 & 11)
	Door obstructed and reverses.	Clear obstruction.
Door will not open fully.	Door limit positions need to be reset.	Reset limit positions. (Section 10 & 11)
	Door obstructed.	Clear obstruction.
Auto-Close not working.	Safety Beam not installed.	Install Safety Beam.
	Safety Beam or wiring faulty.	Repair Safety Beam or replace wiring.
	Safety Beam not aligned correctly.	Re-align optics.
	SafetyBeam is obstructed.	Remove obstruction from path of Safety Beam
	Door obstructed when closing or opening.	Remove obstruction.
	Auto-Close time not set.	Set Auto-Close times. (Section 13)

# 20. Maintenance



**WARNING!** Failure to maintain your door may void the warranty on your door opener.



**CAUTION:** Door adjustments should only be carried out by experienced persons, as this function can be dangerous if not performed under strict safety procedures



**ELECTROCUTION!** Disconnect the opener power cord from the mains power before making any door repairs / maintenance or removing the opener button cover.

## 20.1 Door Maintenance

The door should be tested manually regularly to ensure it is in good condition. A poorly maintained door could cause fatal or serious injuries or serious damage to property. Therefore it is recommended:

- Frequently examine the door, particularly the cables, springs and mountings for signs of wear, damage or imbalance. **DO NOT USE** if repair or adjustment is needed since a fault in the installation or an incorrectly balanced door may cause injury.

## 20.2 Lubrication (every 3 - 6 months)

To ensure a long and trouble free life for your door the following is recommended:

- Lubricate the drive chain.
- Guide Tracks: Clean the internal sections of the guide tracks with a cloth dampened with mineral turps or methylated spirits.

## 20.3 Door Service and Repair

If correct maintenance and servicing are not carried out, warranty may be void. To keep your door running well, it is recommended that your door be serviced by an experienced technician, every **12 months** or earlier if required:

- Check the manual operation of the door by using the hand chain.
- Fasteners: Check all screws, nuts and bolts to ensure they are secure.

## 20.4 Opener Maintenance

To ensure a long and trouble free life for your opener the following is recommended:

- Monthly:
  - i. Check the tension, condition and alignment of the drive chain. Adjust / replace if required.
  - ii. Check the operation of the Safety Beams.
- Quarterly:
  - i. Check tightness of the fixing bolts and grub screw of the sprocket.

**NOTE:** If the door does not operate smoothly, call your industrial door professional.

## 20.5 Service Indicator

As a reminder the Axess Pro 1505 has a built in maintenance counter. This counter has a factory default of 60,000 cycles, and it is adjustable from 0 to 60,000 cycles. When this counter expires, at the start of each door movement the beeper will sound three times and "SERVICE DUE" message displays on the console.

At this time Automatic Technology recommends you contact your industrial door professional to perform an annual door service.

### Service Record

Record any maintenance in the following table to assist in any warranty service.

Date	Service by Company Name	Print Name	Signature	Warranty Counter Number



# 21. Appendix

## A - Console Menu Structure

### OPERATIONAL BUTTONS:

1. Press PREV/NEXT buttons move to Left/Right.
2. Press OPEN/CLOSE buttons to change setting.
3. Press SET button to save changes.
4. Press STOP to return to MENU without saving changes.

**NOTE:** The System will automatically return to the main screen after 30 secs if a menu screen is displayed and no buttons are pressed.

Parameter	Min	Max	Default	Step	Unit	Menu No.	Section
Menu 1 - Code Transmitter							
STORING TRANSMITTERS	0.0	511				1	13.1
Menu 2 - Current Trips							
Full Load Amps 0.5 HP model AX3105	0.0	1.6	1.6	1	Amps	2.1	Appendix C
100% Overload Time	0	30	10	1	Sec	2.2	Appendix C
Menu 3 - Auto Close							
STD AUTO-CLOSE TIME Sets and enables the standard Auto-Close time	0.0	300.0	0.0	1.0	Sec	3.1	13.2
S.B AUTO-CLOSE TRIG Selects the Safety Beam or combination of Safety Beams to enable the S.B triggered Auto-Close mode.	None		None			3.2	13.3
S.B AUTO-CLOSE TIME Sets and enables the S.B triggered Auto-Close time	0.0	60.0	0.0	1.0	Sec	3.3	13.3
PEDESTRIAN AUTO-CLOSE TIME Sets and enables the Pedestrian Auto-Close time	0.0	60.0	0.0	1.0	Sec	3.4	13.4
S.B PEDESTRIAN AUTO-CLOSE TRIG Selects the Safety Beam or combination of Safety Beams to enable the S.B triggered Pedestrian Auto-Close mode.	None		None			3.5	13.4
S.B PEDESTRIAN AUTO-CLOSE TIME Sets and enables the PE Pedestrian Auto-Close time	0.0	60.0	0.0	1.0	Sec	3.6	13.4
AUTO-CLOSE AFTER CLOSE OBSTRUCTION Enables Auto-Close feature after close obstructions (requires Safety Beams)	Off	On	Off			3.7	13.5
AUTO-CLOSE AFTER OPEN OBSTRUCTION Enables Auto-Close feature after open obstructions	Off	On	Off			3.8	13.5
AUTO-CLOSE AFTER POWER UP Enables Auto-Close feature power up	Off	On	Off			3.9	13.5
Menu 4 - Light / Lock Times							
ON AFTER CYCLE LIGHT TIME Time light remains on for after a cycle	0	255	60	1	Sec	4.1	15.1
ON BEFORE OPEN CYCLE LIGHT TIME Minimum time light is activated for prior to opening	0	25.5	0	0.1	Sec	4.2	15.1
ON BEFORE CLOSE CYCLE LIGHT TIME Minimum time light is activated for prior to closing	0	25.5	0	0.1	Sec	4.3	15.1
Menu 5 - Motor Settings							
OPEN SPEED FREQUENCY Sets the speed of the motor	15	75	50	1	HZ	5.1	Appendix C
CLOSE SPEED FREQUENCY Sets the speed of the motor	15	75	50	1	HZ	5.2	Appendix C

# Appendix

## A - Console Menu Structure

Parameter	Min	Max	Default	Step	Unit	Menu No.	Section
Menu 6 - Operating Modes							
Safety Close Mode	Off	On	On			6.1	13.1
Safety Open Mode	Off	On	Off			6.2	Appendix C
Safety Beam Input Response Mode Sets the S.B response mode. Options are OPEN and CLOSE cycles stop, Close cycles stop or Close cycle reverse	OPN & CLS stop CLS to stop CLS to reverse		CLS to reverse			6.3-5	Appendix C
SB REVERSE TIME	5	FULL	FULL	1	Sec	6.6	Appendix C
GPI INPUT MODE configure the GPI input. Options are OSC, PED, SWP and DAY LIGHT SAVING	OSC, PED, DST		OSC			6.7	Appendix C
PED INPUT = SWIPE MODE Selects PED input functions as pedestrian access swipe input	Off	On	Off			6.8	Appendix C
OPN INPUT N/C OPERATION Selects operating polarity of OPN input	Off	On	N/O			6.9	Appendix C
STP INPUT N/C OPERATION Selects operating polarity of STP input	Off	On	N/O			6.10	Appendix C
FIRE INPUT N/C OPERATION Selects operating polarity of FIRE input	Off	On	N/O			6.11	Appendix C
FIRE INPUT MODE configure the fire input. Options are OPN, CLS and PED	OPN, CLS, PED		OPN			6.12	Appendix C
REMOTE CODE ENABLED Selects remote transmitter coding function	Off	On	On			6.13	Appendix C
ACTIVITY REPORTS Select report to be output	Off	255	Off	1		6.14	Appendix C
ACTIVITY REPORT ID Selects ID for controller, sent with activity report	0	65535	0	1		6.15	Appendix C
VACATION MODE Selects Vacation Mode - disables remote control	Off	On	Off			6.16	Appendix C
PASSWORD Selects password protection for all changes	Off	On	Off			6.17	Appendix C
Transmitter Grouping	Off	On	Off			6.18	Appendix C
Fault Auto Reset Selects Fault Auto Reset	Off	On	Off			6.19	Appendix C
LED Low Power Mode Selects saving the power by turning LEDs Off	Off	On	Off			6.20	Appendix C
Console OSC Buttons Selects to lock out the console buttons	Off	On	On			6.21	Appendix C
AUX OUT O/P can be activated by either LIGHT DRIVE ,CLOCK/TXER/SB, OPEN or CLOSE status			LIGHT DRIVE			6.22	Appendix C
Menu 7 - Time Clock							
SET TIME / DATE	Off	On	Off			7.1	14.1
VIEW / EDIT PROGRAMS	Off	On	Off			7.2	14.2
SETTINGS	Off	On	Off			7.3	14.3

# Appendix

## A - Console Menu Structure

Parameter	Min	Max	Default	Step	Unit	Menu No.	Section
Menu 8 - Diagnostics							
TEST INPUTS - Controls input display status			Inactive			8.1	Appendix D
TEST TRANSMITTERS (TX'ERS)						8.2	Appendix D
DISPLAY HISTORY						8.3	Appendix D
MEMORY USAGE						8.4	Appendix D
SERVICE COUNTER			60,000			8.5	Appendix D
EVENT COUNTER						8.6	Appendix D
INSTALL DATA						8.7	Appendix D
PARAMETERS						8.8	Appendix D
VERSION INFO - Firmware						8.9	Appendix D
Menu 9 - Memory Tools							
CLR CONTROL						9.1	Appendix E
CLR TRANSMITTERS (TX'ERS)						9.2	Appendix E
Menu 10 - Setup Travel							
SETUP LIMITS						10.1	8.1 or 9.4
REPROFILE TRAVEL						10.2	9.5
SET PEDESTRIAN						10.3	12.1

# Appendix

## B - Viewing & Editing Logic Console Parameters

This section illustrates how to locate, view and adjust parameters in the logic console unit.

### Locating parameters

Refer to the CONSOLE MENU STRUCTURE or the preceding section for CONTROL BOARD ADJUSTMENTS. Locate the required parameter and note the MENU number. The example used in **(Fig. B.1)** displays Menu 2.2 "100% O/L Time"

### Changing Settings

- Press NEXT/PREV to navigate to the required menu.
- Press SET to show the sub-menu.
- Press NEXT/PREV to go to the required sub-menu.
- Press OPEN/CLOSE to enter Edit mode and change parameter setting **(Fig B.2)**.
- Holding the button down causes the parameter's value to change rapidly.
- The longer the button is held, the faster the value changes.
- Press SET to SAVE the setting.

### Reload Default Setting

- Press NEXT/PREV buttons to display the LOAD DEFAULT screen.
- Press SET to load the default value.

### Return To Menu

If the parameter's value is not to be changed, press STOP to return to the sub menu. Press STOP again to return to the MAIN SCREEN.

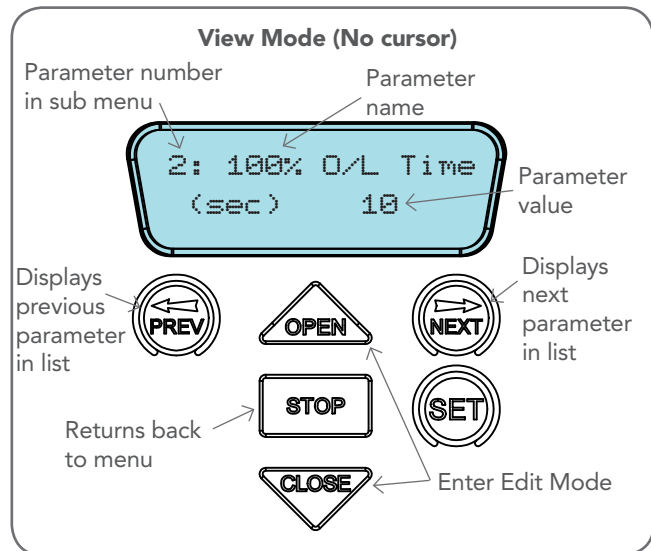

Fig B.1

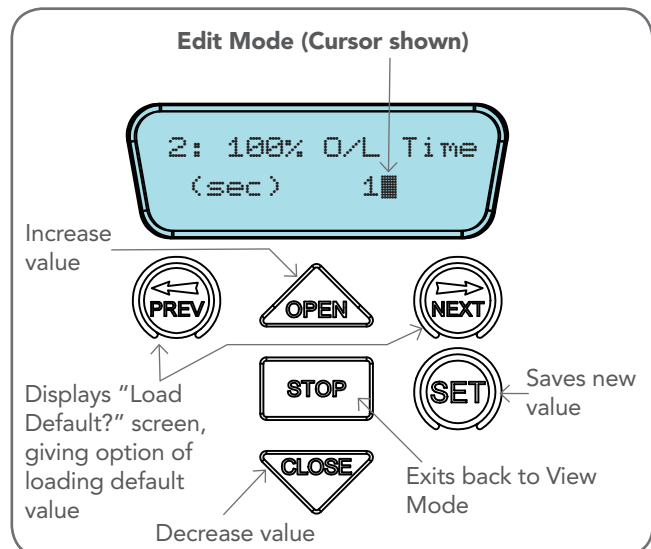

Fig B.2



# Appendix

## C - Control Board Adjustments

The standard operation of the opener can be altered by editing various parameters. This section describes the parameters and the effect they have. Use the VIEWING AND EDITING PARAMETER PROCEDURE (Appendix B) to make changes.

### Menu 2 Current Trips

Motor overload detection is provided to protect the Door and the opener. The motor is designed to run with full load current. For one horse power motor with the default values the opener will run with 7.4 Amps for 10 seconds before going into overload.

### Menu 5. Motor Settings

Motor speed: The maximum speed the motors run at is controlled by the OPEN AND CLOSE SPEED VOLTAGE parameter. The default value is the maximum recommended for normal operation. If however the Door moves too quickly or too slowly for a particular installation, the frequency / time can be reduced to make the motors run slower or faster.

**NOTE:** Altering these parameters will cause the travel limits to be cleared.

Motor Speed Control - soft start/soft stop: The speed of the motor is controlled by a microprocessor which ramp up the speed as the Door starts to move, and ramp down the speed as it approaches the travel limits to provide a gentle stop. This provides a gentle start and stop.

### Menu 6

#### Menu 6.2 Safety Open Mode

By enabling this parameter, the user can open the Door only by holding the open button on the wall control unit or by holding the open input active. The Door can not be opened by the transmitters.

#### Menu 6.3 First (SB1) Safety Beam Response Mode

The Safety Beams input can be configured to respond in one of eight modes.

- i. **Reverses Close Cycles** In this mode, the Safety Beam input has no effect when opening but will cause the door to reverse if activated when closing.
- ii. **Close Cycles Stop** In this mode, the Safety Beam input has no effect when opening but will stop the door when closing.
- iii. **Open and Close Cycles Stop** In this mode, all cycles are prevented from being completed or initiated when the Safety Beam input is active.
- iv. **Open input** In this mode, open cycle is initiated when the Safety Beam is activated.
- v. **Swipe input** In this mode, open cycle is initiated when the Safety Beam is activated.
- vi. **Close input** In this mode, close cycle is initiated when the Safety Beam is activated.
- vii. **Ped input** In this mode, ped cycle is initiated when the Safety Beam is activated.
- viii. **Aux O/P trigger** In this mode, aux output is triggered when the Safety Beam is activated.
- ix. **Disabled** In this mode, Safety Beam is disabled.

#### Menu 6.4 Second Safety Beam (SB2) Response Mode

Same as above menu 6.3

#### Menu 6.5 Third Safety Beam (SB3) Response Mode

Same as above menu 6.3

#### Menu 6.6 Safety Beam Obstruction Reverse Time Mode

Normally after a Safety Beam obstruction the door will fully open to its open position. After a Safety Beam Close obstruction, the doors open cycle can be reduced from 5 sec to its full open position.

#### Menu 6.7 GPI Input

GPI input can be configured as OSC, PED or DST setup. The GPI input terminal is activated by the N/O switch.

- i. **When GPI Selected As OSC:** If the door is moving, the activation of the GPI input or by a transmitter button with the OSC function assigned will cause the door to stop. The next trigger will move the door in the opposite direction to the last travelled.
- ii. **When GPI Input Is Configured As PED:** The activation of the GPI input or by a transmitter button with PED function assigned will open the door partially to allow pedestrian access but prevent vehicle access. The position the door is driven to is automatically set to halfway during setting of the travel limits, but can be adjusted to suit.
- iii. **When GPI Input Is Configured As SWP:** Activation of GPI input in this mode will open the door.
- iv. **When GPI Input Is Configured As MANUAL OPERATION:** Activation of GPI input in this mode will disable all the transmitters.
- v. **When GPI Input Is Configured As DST:** The GPI input can be used to switch between STD time and DST (daylight savings time). The time selected is the amount of time added to STD time when DST is selected. The Options are OFF, 30, 60, 90 or 120 minutes. The GPI input needs to be constantly active to show day light saving time.

#### Menu 6.8 PED Input Function

If GPI or Fire Input is selected as PED then these inputs can be configured to a SWIPE type input for pedestrian access. This provides full functionality with the Safety Beam Triggered Pedestrian Auto-Close function.

#### Menu 6.9 Open Input Polarity

The OPN input is normally configured for N/O operation. This parameter allows its operation to be changed to N/C.

#### Menu 6.10 STP Input Polarity

The STP input is normally configured for N/O operation. This parameter allows its operation to be changed to N/C.

#### Menu 6.11 FIRE Input Polarity

The FIRE input is normally configured for N/O operation. This parameter allows its operation to be changed to N/C.

#### Menu 6.12 FIRE Input Configuration

Fire input can be configuration as OPN ,CLS (available only if Safety Beams are installed) or PED function. Activated by FIRE input terminal with N/O or N/C (if selected) switch.

- i. **When Fire Input Is Configured As CLS :** Activating the fire input will cause the Door to close only if Safety Beams are installed. Holding the input active will prevent Door from opening.
- ii. **When Fire Input Is Configured As PED:** The activation of fire input will open the Door partially to allow pedestrian access but prevent vehicle access. The position the



# Appendix

## C - Control Board Adjustments

Door is driven to is automatically set to halfway during setting of the travel limits, but can be adjusted to suit.

**iii. When Fire Input Is Configured As OPN :** Activating the fire input will cause the Door to open. Holding the input will prevent the Door from closing.

### 6.13 Remote Code

The controller supports the Remote Code Set feature. This parameter can be used to disable the feature for security or transmitter management reasons.

### 6.14 Activity Reports

This parameter enables activity report outputs. Contact Automatic Technology for more details.

### 6.15 Activity Report ID

This parameter sets the ID of the controller that is sent with the activity report. Contact Automatic Technology for more details.

### 6.16 Vacation Mode

Vacation Mode blocks all but one designated remote control transmitter from activating the Axess® Pro 1505. The mode is activated by pressing a transmitter button with the VAC function assigned until the console displays that Vacation Mode is enabled

(approx. 5 secs). When activated all the transmitter buttons will be ignored. To turn Vacation Mode off, press a transmitter button with the VAC function assigned. Vacation Mode can also be turned on or off manually by editing the Vacation Mode parameter. Vacation Mode can be turned on or off using this parameter.

### 6.17 Password Protection

The password feature enables all parameters and configuration settings to be protected unless a password is entered. When this feature is turned on, the user is requested to enter the desired password to be used. The password protection feature has a time-out that expires after 60 seconds of inactivity. Alternatively, the user may log out manually by pressing exit when the main screen is displayed.

### 6.18 Transmitter Grouping

The transmitter store number display format can be changed to show a grouped format. When grouping is selected, instead of displaying the store location as a number between 1 and 511, it will display as ##\$ where ## is the group number and \$ is a character a,b,c,d,e,f,g or h which indicates the group member.

### 6.19 Fault, Auto Reset

When selected, the controller will reset any fault automatically.

### 6.20 LED Low Power Mode

When LED low power mode is selected, the controller will turn the LED power off to save the power.

### 6.21 Console OSC Buttons

Console can be locked out by selecting console OSC buttons OFF.

### 6.22 AUX Output Operation

AUX output can be selected to be driven by:

- i. Light Drive:** Although the GDO10V3L2 drive unit has a light relay output, a light relay module can be connected on the console between V+ and AUX OUT terminal which will turn the courtesy light on and off.
- ii. Clock/Transmitter:** By selecting this option, AUX output can be triggered by programming the clock timer or by the transmitter.
- iii. Open Status:** Selecting this option will cause the AUX output to stay active as long as the Door stays open.
- iv. Close Status:** Selecting this option will cause the AUX output to stay active as long as the Door stays closed.

# Appendix

## D - Diagnostic Tools

The controller provides several diagnostic tools from within the Diagnostics Menu (Menu 8). This section details the function of each tool and its use.

### Navigating To Diagnostics Menu

- Press PREV to navigate to Menu 8 (**Fig. D.1**).
- Press SET to display the menu of available functions.
- Press PREV or NEXT to cycle through diagnostic tools.
- Press SET to select.

### Menu 8.1 Test Inputs

This tool is used to view the state of the control inputs. When selected, a screen is displayed (**Fig. D.2**) which indicates the state of each input. If the name of the input is in upper case or number in the bracket, then the input is active. Conversely if the input is in lower case and [---] dash in the bracket, then the input is inactive. For normal operation, all inputs should be inactive. When finished, press STOP.

### Menu 8.2 Test Transmitters (Tx'ers)

This tool is used to test receiver/transmitter functionality. When selected, a screen is displayed which prompts for a transmitter button to be pressed (**Fig. D.3**) and whether ID or serial numbers are to be displayed.

The opener will then beep each time a transmission is received. If the transmitter button is stored in the controller memory and has a function assigned to it, a second screen will be displayed that shows the transmitter details along with the button pressed (**Fig. D.4**). The example shows the case where transmitter number 14 is activated by button 4. Note ID is selected for display.

### Menu 8.3 Display History

The opener keeps a record of the last 64 events that have taken place. The events include the type of drive cycles executed, obstruction detection, various faults, power failures etc. When this tool is selected, the screen displays the last event that occurred (**Fig. D.5**). Press NEXT or PREV to view each event. The "EVENT#" field shows the sequence of the events, with (1) being the first and (64) being the last. The example shows that the last event was a close cycle which succeeded in closing the door. When finished viewing the events, press STOP to exit.

### Menu 8.4 Memory Usage

This tool displays the number of transmitter store locations used and the number free (**Fig. D.6**).

Fig D.1

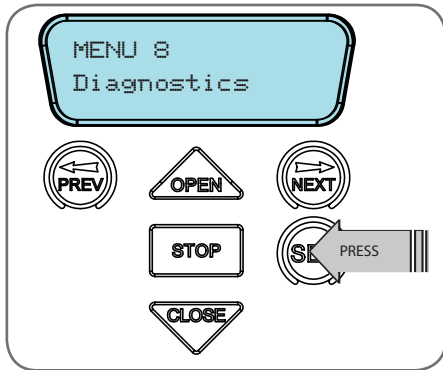

Fig D.2

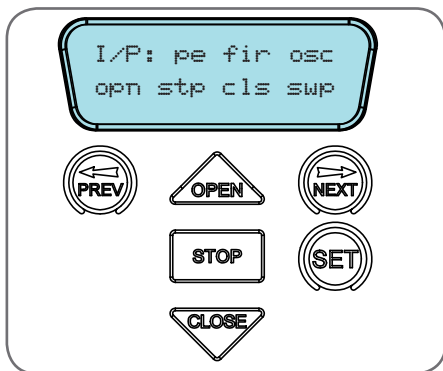

Fig D.3

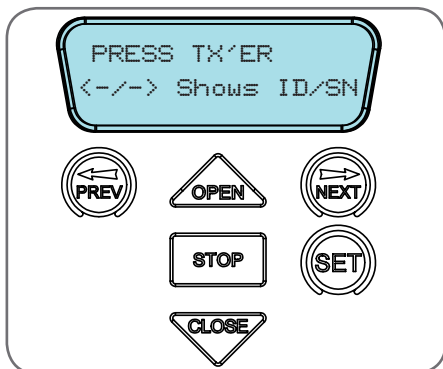

Fig D.4

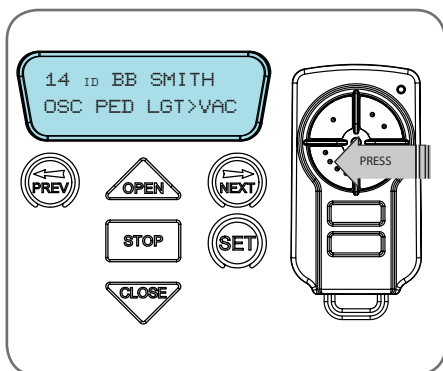

Fig D.5

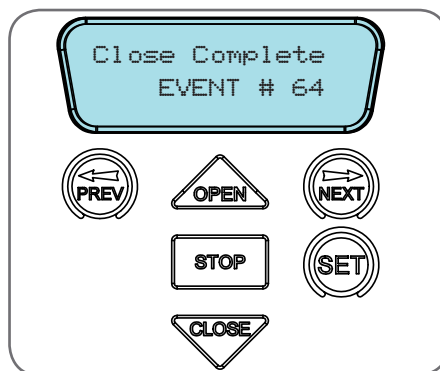
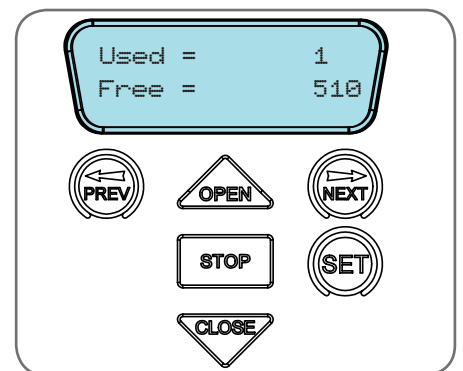

Fig D.6



# Appendix

## D - Diagnostic Tools

### Menu 8.5 Service Counter

The opener provides a periodic service counter which can be set to expire after a number of drive cycles. When expired, the opener will beep three times at the beginning of each drive cycle and a message will be displayed on the MAIN SCREEN (**Fig. D.7**). This tool displays the current value of the service counter and allows the user to set its value using the normal parameter editing techniques (See Appendix B). If the service counter is not to be used, it can be set to the maximum number (60,000).

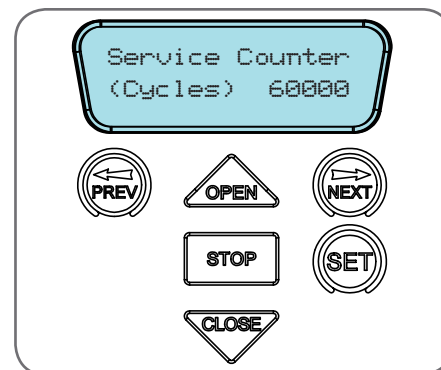

Fig D.7

### Menu 8.6 Event Counters

The opener keeps a count of number of times a particular event occurs. The list of event counters kept is shown below. When this tool is selected, the first event counter is shown (**Fig. D.8**). Press NEXT or PREV to step through the list. The example shows the OPEN CYCLE event counter with a value of 500. When finished viewing press STOP.

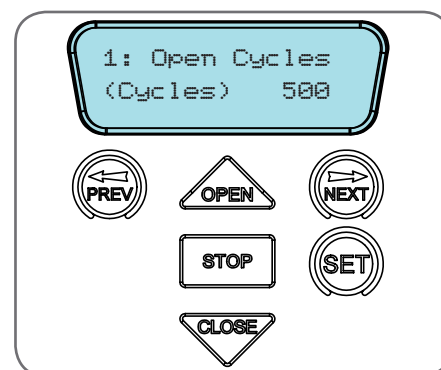

Fig D.8

- |                            |                            |
|----------------------------|----------------------------|
| 1: Open Cycles             | 2: Close Cycles            |
| 3: PED Cycles              | 4: Setup Limits            |
| 5: Warranty Cycles         | 6: Open O/LS               |
| 7: Close O/LS              | 8: Open Stalls             |
| 9: Close Stalls            | 10: Direction Faults       |
| 11: Position Sensor faults | 12: Drive Memory Faults    |
| 13: Position Wrap Faults   | 14: Console Volt Faults    |
| 15: PCB Temp Fault         | 16: Comms Compat Faults    |
| 17: INV logic faults       | 18: Low DC Bus Volt Faults |

### Menu 8.7 Install Data

- i. **Open Position:** Shows the fully open position door counter.
- ii. **PED Position:** Shows the pedestrian position counter.
- iii. **Open Time:** Time taken for the opener to drive the door to open position.
- iv. **Close Time:** Time taken for the opener to drive the door to the close position.

### Menu 8.8 Parameters

Position of the limit counter, frequency, current used by the motor, overload graph, PCB temperature and DC bus voltage are displayed under this menu. All the parameters mentioned above can also be viewed while the opener is running. By default, the current used by the motor will be displayed on the LCD screen. This can be useful to check the condition of the Door. Scroll through other parameters by pressing NEXT or PREV buttons while the Door is running

### Menu 8.9 Version Info

Firmware information for the Axess® Pro 1505's drive and console are shown here.

# Appendix

## E - Memory Tools

### Menu 9.0 Memory Tools

The Memory Tools accessed from within Menu 9 are used to clear the transmitter codes from the openers memory and clear the controller's memory. Once selected the PREV or NEXT buttons can be used to view the Memory Tool options. To execute the displayed option simply press SET.

### Menu 9.1 Clear Control

This option will clear the Door control memory and reload the factory set defaults for parameters such as the lock time, light time, Auto-Close times etc. It will also clear the travel limits.

### Menu 9.2 Clear Transmitters (Tx'ers)

This option will clear the transmitter storage memory.

# Appendix

## F - Transmitter Editing

### Display Transmitter Record

Using one of the methods below, you can display the required transmitters details.

### Navigating To "Edit Transmitter" Menu

- Press NEXT to navigate to Menu 1 (**Fig. F.1**).
- Press SET to enter the transmitter edit procedure.
- Press NEXT to enter transmitter list and edit mode.

### Editing Button Function Field

- Press NEXT or PREV to move the cursor to the left or right and between the top and bottom lines to select the desired field.
- Press OPEN or CLOSE to change the displayed value (**Fig. F.2**). The available functions are shown below. Selecting OFF will prevent the opener responding to that button.

### Available functions

OSC (Open/Stop/Close)  
PED (Pedestrian access)  
SWP (Swipe)  
CLS (Close)  
OPN (Open)  
STP (Stop)  
LGT (Courtesy Light)  
VAC (Vacation Mode)  
AUX (Auxiliary)  
OFF (No action)

**NOTE:** OSC will change to OS and CLS (Close) function is not available in the case where PE Beams are not installed.

- Press SET to save changes or press NEXT or PREV to move to the next field.
  - The example in (**Fig. F.3**) shows that PED is assigned to the transmitter button two.
  - The transmitter in the example is transmitter number 14 which has the ID label AB Smith.

**NOTE:** If all button functions are set to OFF, when SET is pressed, the opener will prompt to confirm if the transmitter is to be deleted. Press SET to delete or STOP to continue editing.

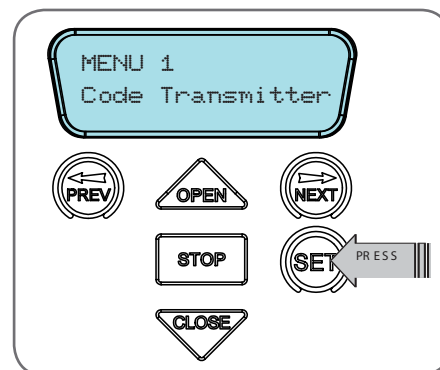

Fig F.1

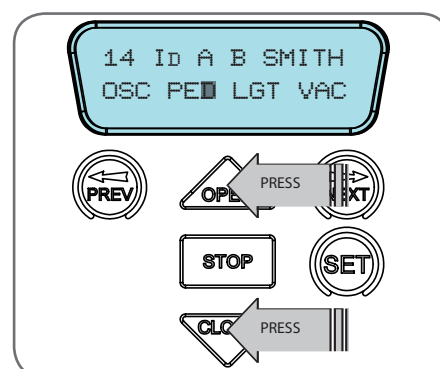

Fig F.2

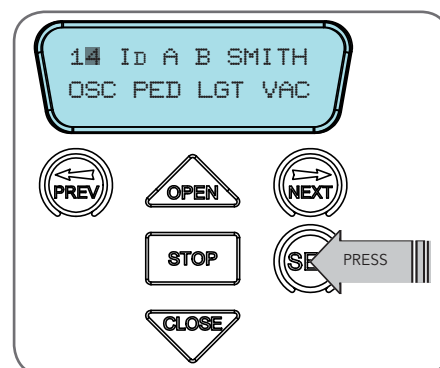

Fig F.3

# Appendix

## F - Transmitter Editing

### Editing The Store Location

This feature is only available when coding the first button of a new transmitter.

- Press NEXT or PREV to move the cursor over Store No. (**Fig. F.4**)
- Press UP or DOWN to select new Store No.
- Press SET to confirm or NEXT/PREV to move to the next field.

This is useful when managing transmitters using a scheme which ties the store location to the transmitter's owner.

### Selection Of ID or Serial Number Display

- Press NEXT to navigate to Menu 1 "Code Transmitter".
- Press SET to enter the transmitter edit procedure.
- Press NEXT to enter transmitter list and edit mode.
- Press NEXT/PREV to move the cursor over the ID field.
- Press NEXT to reveal the Serial Number (**Fig. F.5**).

The serial number display is provided for additional means of identification. The transmitter in this example has serial number 12345.

### Editing A Character Field

- Press NEXT or PREV to move the cursor. (**Fig. F.6**)
- Press UP or DOWN to scroll through and select a new character.
- Press NEXT or PREV to move the cursor to the next character.
- Repeat step 2.
- Press SET to record changes.

The second line of the display shows a list of available characters with the current value indicated at the cursor position (**Fig. F.7**).

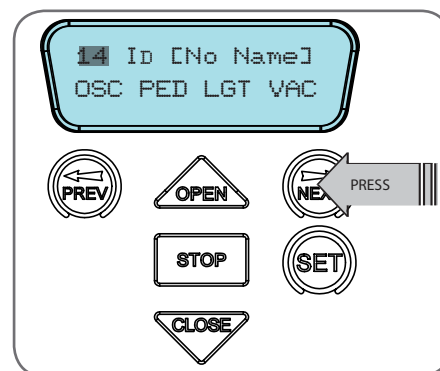

Fig F.4

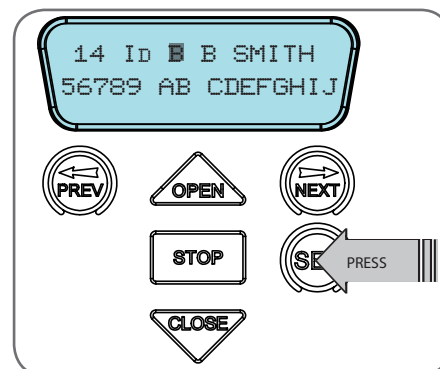

Fig F.6

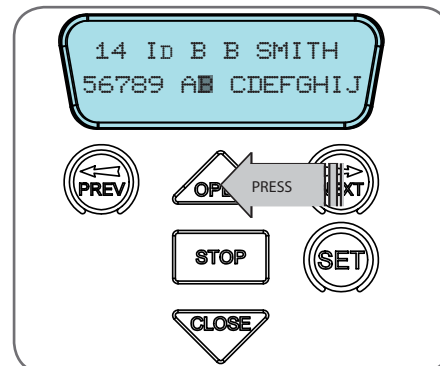

Fig F.7

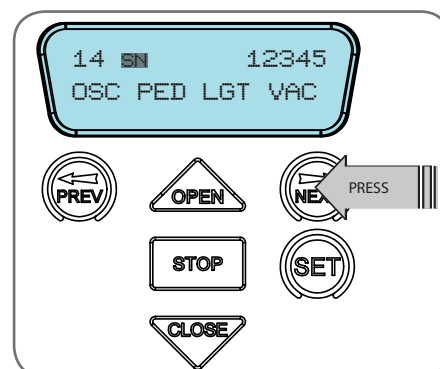

Fig F.8



# Appendix

## G - Transmitter Management

### Transmitter Listing Facility

The Axess® Pro 1505 provides a transmitter listing facility which enables the user to find a transmitter location within the memory. Once located a stored transmitter can be replaced, deleted, edited, copied or, if the location is empty, a new transmitter can be coded.

#### Method 1 - Go To The Start Of The List Accessing The List Menu

- Press NEXT to navigate to Menu 1 (**Fig. G.1**).
- Press SET to enter the transmitter edit procedure.
- Press NEXT to enter the transmitter list and edit mode.

#### Method 2 - Use The Transmitter To Go Direct To The List Accessing The List Menu

- Press NEXT to navigate to Menu 1 (**Fig. G.1**).
- Press SET to enter the transmitter edit procedure.
- Press the transmitter once (**Fig. G.2**).
- Press NEXT to view the transmitter parameters (**Fig. G.3**). This method is used for quick navigation if the transmitter is available.

**NOTE:** "VIEW" will not be shown if the transmitter is not stored. Once the list is displayed, it can be sorted by stored number, ID Label or Serial Number. Use the NEXT or PREV buttons to select the sorting method.

**NOTE:** When sorting by ID label or S/N, only stored transmitters locations are displayed.

#### Navigating The List

- Press the OPEN or CLOSE buttons to navigate through the list (**Fig. G.4**).
- NOTE:** Holding a button down will step through the list faster.
- Press SET to display the menu of available functions.

#### Selecting An Operation

- Press NEXT or PREV to cycle through the four menu options (**Fig G.5**)
- Press STOP to return to the list. Press SET to execute the menu's operation.

Menu Option	Operation
<b>Code Operation (location used)</b>	If the code operation is selected for a location that already contains a transmitter, then the storing transmitter code procedure (Section 10.1) will be initiated and the new transmitter will replace the existing one. Note the button functions and name of the existing transmitter will be transferred to the new transmitter. This procedure is of great convenience when replacing a lost transmitter.
<b>Delete Operation</b>	The delete operation is used to remove a transmitter from memory along with the name and button function settings.
<b>Edit Operation</b>	The edit operation displays the transmitter record for editing purposes. See TRANSMITTER EDIT PROCEDURE (Appendix B) for details.
<b>Copy Operation</b>	The copy operation is used to code multiple transmitters with the same button function as that of the selected transmitter. Once selected an abbreviated code set routine is initiated which repeats steps 2 & 3 of the BASIC CODE TRANSMITTER PROCEDURE for each transmitter to be coded. Coding is terminated by pressing the STOP button.
<b>Exiting The List</b>	To exit the transmitter list, simply press STOP to return to the Code menu.

**Fig G.5**

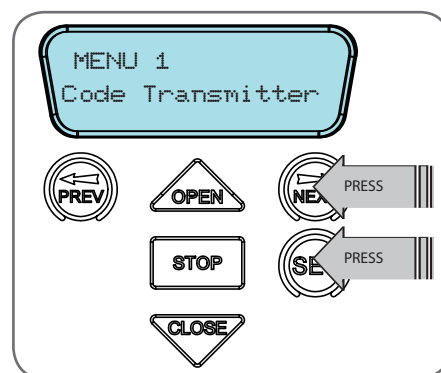

**Fig G.1**

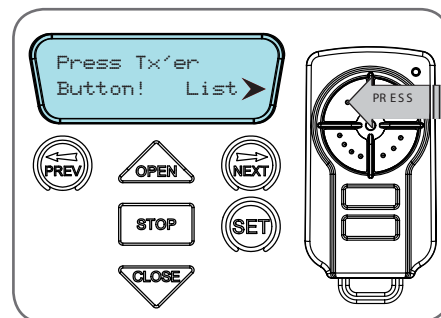

**Fig G.2**

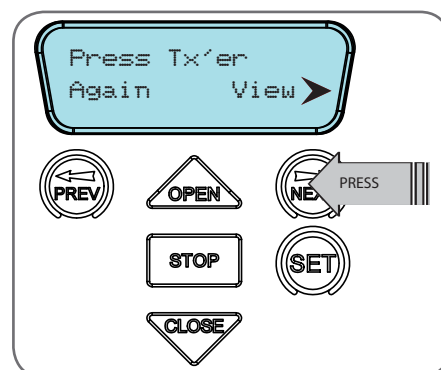

**Fig G.3**

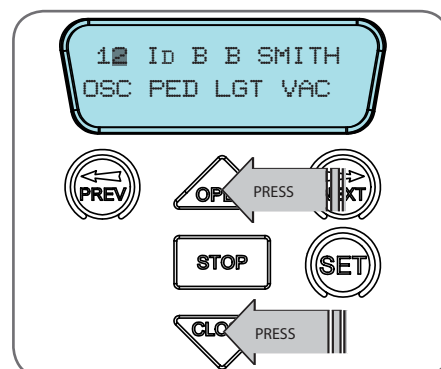

**Fig G.4**

# Warranty and Exclusion of Liability

1. This Warranty is given by Automatic Technology (Australia) Pty Ltd (ABN 11 007 125 368) (ATA). 6-8 Fiveways Boulevard, Keysborough 3173, 1300 133 944, sales@ata-aust.com.au
2. The Competition and Consumer Act 2010 (including the Australian Consumer Law) and other relevant statutes provide a set of statutory consumer guarantees and other legal rights that cannot be excluded, restricted or modified by contract. This Warranty is in addition to and does not affect any of your rights under the Australian Consumer Law and other relevant statutes.
3. Our goods come with guarantees that cannot be excluded under the Australian Consumer Law. You are entitled to a replacement or refund for a major failure and for compensation of any other reasonably foreseeable loss or damage. You are also entitled to have the goods repaired or replaced if the goods fail to be of acceptable quality and the failure does not amount to a major failure.
4. Subject to your non-excludable rights under the Australian Consumer Law, ATA expressly excludes any liability for consequential loss, incidental or indirect damages (including but not limited to damages for loss of business profits, business interruption and loss of business information) due to a defect of the Axxess® 1505 Opener (Product). In particular any loss or damage caused to other equipment or accessories used with the product or any loss resulting from a delay in repair is excluded to extent permitted by law.
5. Subject to all of the matters set out below, ATA warrants in relation to the Product that:
  - a. the Product's drive units will be free of any defects in material and workmanship for:
    - ii. Axxess® Pro 1505 Powerheads - at least 24 months after the date of purchase (as evidenced by the sales docket receipt), or 5000 cycles, whichever occurs first;
  - and;
  - b. the Product's other components and accessories will be free of any defects in material and workmanship for at least 12 months after the date of purchase (as evidenced by the sales docket receipt).
6. No additional warranty will apply for Products repaired during the relevant warranty period.
7. or all Products repaired outside the warranty period, a six (6) month warranty that the Product will be free of any defects in material and workmanship will apply from the date of dispatch of the Product to you. ATA may charge you for any repairs undertaken outside the warranty period, and will provide you with a quotation in relation to any such costs for your approval before proceeding with any repairs.
8. This Warranty applies only where you:
  - a. immediately notify ATA at the contact details provided in paragraph 1 above or notify the or the retailer that you purchased the Product from of the alleged defect;
  - b. return the product to the retailer that you purchased the Product from; and
  - c. present the relevant sales docket and this Warranty document to the retailer to confirm the date of purchase.
9. Except for this Warranty, ATA gives no warranties of any kind whatsoever (whether express or implied), in relation to the product, and, subject to paragraph 1 above, all warranties of whatsoever kind relating to the product are hereby excluded.
10. This Warranty excludes damage resulting from:
  - a. normal wear and tear;
  - b. accidental damage;
  - c. incorrect installation of the Product;
  - d. blown fuses, electrical surges, power surges or power spikes;
  - e. theft, fire, flood, rain, water, lightning, storms or any other acts of God;
  - f. any installation, configuration or use of the Product contrary to the instructions supplied with the Product;
  - g. the surface area or weight of the door used with the Product exceeding the technical specifications supplied with the Product;
  - h. the door used with the Product not being in safe working order and condition;
  - i. repairs which are not authorised by ATA;
  - j. any failure to maintain the Product in accordance with the instructions supplied with the Product;
  - k. deliberate or negligent damage to the Product;
  - l. any unauthorised modification to the Product;
  - m. radio interference; or
  - n. acts or omissions of any person other than ATA.
11. ATA's liability under this Warranty is limited, at ATA's absolute option, to replacing or repairing the product which ATA, in its unfettered opinion, considers to be defective either in material and/or workmanship or to credit the dealer with the price at which the product was purchased by the dealer.
12. This Warranty does not extend to cover labour for installation of the Product following repairs, the cost of which must be borne by you.
13. This Warranty is limited to Return-to-Base (RTB) repair and does not cover labour for on-site attendance, the cost of which must be borne by you.
14. Except as specified in this Warranty, ATA will not charge you for any repairs or replacements conducted under the Warranty. However, ATA will charge you for any repairs which are not within the scope of this Warranty (or which are not required to be undertaken free of charge pursuant to the Australian Consumer Law).
15. This Warranty is void if the Product is not returned to the manufacturer in original or suitably secure packaging.
16. This Warranty is only applicable for repairs to the product carried out within Australia.
17. This Warranty does not cover consumable items including, without limitation, globes, batteries and fuses.
18. This Warranty is not transferable.
19. This Warranty is void if a Photo Electric Beam Sensor is not fitted to the door opening.
20. Where the Product is retailed by any person other than ATA, except for the warranty set out above, such person has no authority from ATA to give any warranty or guarantee on ATA's behalf in addition to the warranty set out above.
21. Any provision of this Warranty that is prohibited or unenforceable in any jurisdiction is ineffective as to that jurisdiction to the extent of the prohibition or unenforceability. That does not invalidate the remaining provisions of this Warranty nor affect the validity or enforceability of that provision in any other jurisdiction.
22. Products presented for repair may be replaced by refurbished goods of the same type rather than being repaired. Refurbished parts may be used to repair the Product.

## NOTES:

1. One (1) cycle = one (1) open and one (1) close action of the door.
2. This Warranty is to be read in conjunction with the owner's copy of the installation instruction manual.

© Feb 2015 Automatic Technology (Australia) Pty Ltd. All rights reserved. Axxess® and TrioCode™128, are trademarks of Automatic Technology (Australia) Pty Ltd. No part of this document may be reproduced without prior permission. In an ongoing commitment to product quality we reserve the right to change specification without notice. E&OE.

automatic  
TECHNOLOGY

## Automatic Technology (Australia) Pty Ltd

ABN 11 007 125 368

6-8 Fiveways Boulevard  
Keysborough, Victoria, 3173, Australia

P 1300 133 944

E sales@automatictechnology.com.au

www.automatictechnology.com.au

SMART  
SIMPLE  
SECURE