

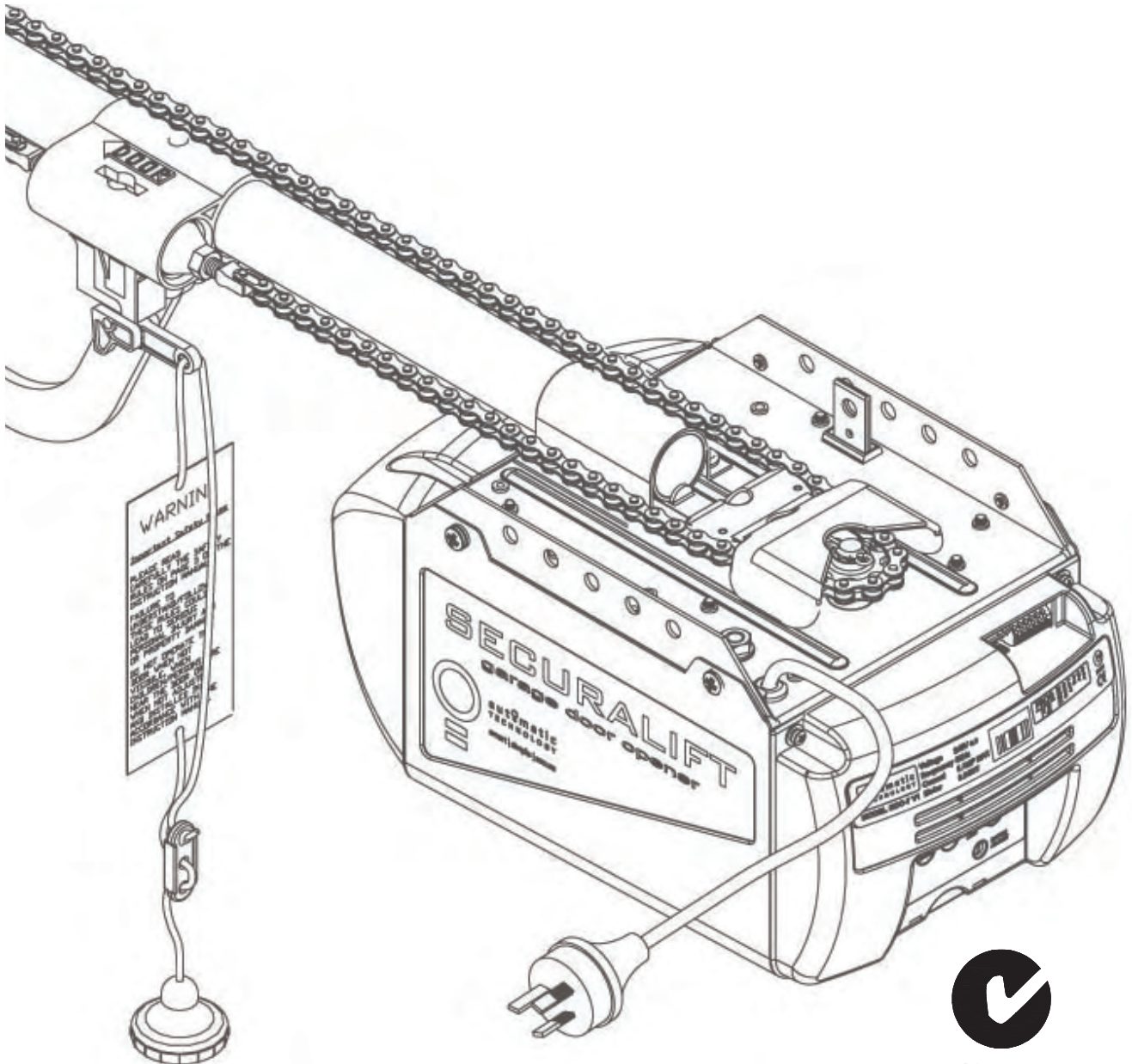

GDO-7V1 SecuraLift®

Overhead Garage Door Opener



N1854

automatic
TECHNOLOGY

smart | simple | secure



WARNING: It is vital for the safety of persons to follow all instructions. Failure to comply with the installation instructions and the safety warnings may result in serious personal injury and/or property and remote control opener damage. Please save these instructions for future reference.

Automatic Technology Australia Pty Ltd to the extent that such may be lawfully excluded hereby expressly disclaims all conditions or warranties, statutory or otherwise which may be implied by laws as conditions or warranties of purchase of an Automatic Technology Australia Pty Ltd Garage Door Opener. Automatic Technology Australia Pty Ltd hereby further expressly excludes all or any liability for any injury, damage, cost, expense or claim whatsoever suffered by any person as a result whether directly or indirectly from failure to install the Automatic Technology Australia Pty Ltd Garage Door Opener in accordance with these installation instructions.



GDO-8V1 SecuraLift®

Overhead Garage Door Opener

Safety Precautions	4
Opener Features	6
Operating Controls	6
Kit Contents	10
Installation	11
Tube Pipe Assembly	11
Determine Door Type	12
Mounting - Track Type Door	12
Using inbuilt antivibration brackets	14
Mounting - Spring Loaded Door	15
Mounting Door Bracket & Arms	16
Easy Access Transmitter	16
Programming the Opener	17
Setting Travel Limits - Control Pane	17
Setting Travel Limits - Transmitter	18
Safety Obstruction Force Test	19
Coding Transmitters	20
Door	20
Courtesy Light	20
Vacation Mode	20
Pet Mode	20
Storing Transmitter From Remote Location	21
Erasing Transmitter Codes	21
Accessories	22
Photo Electric Beam	22
Auto-Close	22
Final Set Up	23
Courtesy Light Time	23
Pet Mode Door Height	23
Transmitter Wall Bracket	23
Re-Initializing	23
Parameters	24
Door Status Indicators	24
System Specification	26
Factory Default Settings	26
Trouble Shooting Guide	28
Maintenance Record	29
Parts List	30
Warranty	32





Important safety instructions

WARNING: It is vital for the safety of persons to follow all instructions. Failure to comply with the following Safety Rules may result in serious personal injury and/or property damage.

CAUTION: If your garage has no pedestrian entrance door, an emergency access device should be installed. This accessory allows manual operation of the garage door from outside in case of power failure.

For **ADDITIONAL SAFETY** protection we **STRONGLY** recommend the fitting of a Photo Electric Beam. In most countries Photo Electric Beams are mandatory on all garage doors fitted with automatic openers. For a small additional outlay ATA recommends that Photo Electric Beams be installed with the automatic opener ensuring additional safety and peace of mind.

DO NOT operate the garage door opener unless the garage door is in full view and free from objects such as cars and children/people. Make sure that the door has finished moving before entering or leaving the garage.

DO NOT operate the garage door opener when children/persons are near the door. Children must be supervised near the garage door at all times when the door opener is in use. **serious personal injury** and/or property damage can result from failure to follow this warning.

DO NOT allow children to operate the garage door opener. **serious personal injury** and/or property damage can result from failure to follow this warning.

Regularly check to make sure that the **safety obstruction force** is working correctly, and is **tested** (by placing a 50mm high object on the floor) and set as per the Installation Instructions Manual. Failure to follow the manual could result in **serious personal injury** and/or property damage. This test must be repeated at regular intervals and the necessary adjustments made as required.

DO NOT disengage the door opener to manual operation with children/persons or any other objects including motor vehicles within the doorway.

The door opener is not intended for use by young children or infirm persons without adequate supervision. Children should be supervised to ensure that they do not play with the remote transmitters or the opener.

Keep hands and loose clothing **clear** of the door and door opener at all times.

The unit should be installed so that it is protected from the elements. It should not be exposed



Important safety instructions

to water or rain. It is not to be immersed in water or sprayed directly by a hose or other water carrying device.

The garage door must be **well balanced**. Sticking or binding doors must be repaired by a qualified garage door installer prior to installation of the opener.

Frequently examine the installation, in particular cables, springs and mountings for signs of wear, damage or imbalance. **DO NOT** use if repair or adjustment is needed since a fault in the installation or an incorrectly balanced door may cause injury. **DO NOT** attempt to repair the door yourself as hardware is under extreme tension.

Remove or disengage all garage door locks and mechanisms prior to installation of the opener.

Connect the garage door opener to a properly **earthed** general purpose 240V mains power outlet installed by a qualified electrical contractor.

Disconnect the power cord from mains power before making any repairs or removing covers. Only **experienced** service personnel should remove covers from the garage door opener.

When using auto close mode, a **photo electric beam** must be fitted correctly and tested for operation at regular intervals. **extreme caution** is recommended when using auto close mode. **all safety rules** must be followed.

In order for the garage door opener to **sense** an object obstructing the door way, some **force** must be exerted on the object. As a result the object, door and/or person may suffer **damage** or **injury**.

If the power supply cord is damaged, it **must** be replaced by an ATA service agent or suitably qualified person.

Make sure that the door is fully open before driving in or out of the garage and fully closed before leaving the driveway.

Make sure that remote controls are kept out of reach of children.

Install the wall switch or wall mounted transmitter in a location where it is out of reach of children and the garage door is visible.





Features

Thank you for purchasing the ATA SecuraLift® Automatic Garage Door Opener. This opener is designed to suit sectional overhead and one piece tilt up doors. The components and materials used in this opener are of the latest technology and highest quality. Listed below are some of the many features.

Operation

To open or close the door simply press the hand held transmitter, the wall mounted transmitter, or optional wall switch for two seconds. During an open or close cycle the door can be stopped by pressing the button while the door is in motion. The next actuation will move the door in the opposite direction.

Hopping code

Every time a transmission is made from the remote transmitter a new security code is generated. The number of possible code combinations is over 4.29 billion. This greatly enhances the security of the system. Code "grabbing" is made a thing of the past.

S-alps (semi automatic limits positioning system)

The ALPS system does away with manual adjustment of the doors' limits position using mechanical parts, such as cams and micro switches. During installation the hand held transmitter can be programmed to set the door limits positions.

Anti travel electronic brakes

opener has anti travel electronic brake mechanism which ensure the opener stops the door at exact location

ISS (intelligent safety obstruction system)

While the door is performing a close cycle, should it hit an obstacle or be restricted in some manner, it will automatically reverse. The amount of force the door should encounter before reversing is automatically adjusted by the doors control system during the initial installation of the automatic door opener. The door will also stop if restricted whilst opening. The Safety Obstruction Force should be checked at least once a month. See installation manual for instructions.

Security code store

The SecuraLift® Garage Door Opener uses state of the art technology in storing your selected transmitter security code. Up to 24 different transmitters can be stored in the openers memory.





Over load indicator

When the maximum opening and closing capacity of the opener is exceeded the red and green Limits LEDs flash alternately to indicate that an overload has occurred.

Auto courtesy light

The courtesy light on the opener comes on automatically whenever the door is activated. The light can also be switched on and off without operating the door. This is done by pressing the button on any hand held or wall mounted transmitter which has been stored with the light code. The light will stay on for approximately three minutes then switch off. This time is also adjustable.

Anti vibration brackets

opener has inbuilt antivibration brackets hang the opener by using anti vibration brackets where noise is the problem.

Vacation mode

A hand held transmitter can be programmed to lock and unlock all other transmitters that have been programmed into the openers' memory. The vacation mode can be used when the door is left idle for long periods of time.

Pet (pedestrian) mode

The hand held transmitter can be programmed to open the door partially so that the family pet can enter and exit the garage at any time. You may also wish to open the door to a height suitable only for pedestrian access. The door opening position is also programmable.

Auto close mode

The opener can be programmed to automatically close after an open cycle. The auto close time is adjustable. It is compulsory to install a Photo Electric Beam if this mode is selected, otherwise the door may cause personal injury or damage to property.

Photo electric beam (optional)

The opener has an input for a photo electric beam to be connected for extra safety protection and use of the auto close mode.

Manual operation

The opener is equipped with a unique manual disengaging device. If the power to the opener is disrupted for any reason the door can be put into manual mode by pulling down on the string handle on an angle towards the door. This will allow you to manually open or close the door. To re-engage the opener pull the string handle away from the door.





Operating controls

- 01 **P. E. Shunt.** The shunt has to be removed when connecting a Photo Electric Beam.

NOTE: P.E. Shunt must not be removed otherwise the opener will not function correctly. Remove only when a P.E beam is to be connected. PROG INPUT is used for the connection of the ATA Handheld Programmer for the purpose of editing control and receiver functions.

- 02 **Terminal Block.** 24V PWR is used to power devices such as photo electric beams.

PE (Input) for photo electric beam for safety and auto-close function.

LGT (Input) allow hard wired external trigger for the opener's courtesy light.

O/S/C INPUT is used for the connection of a wired switch (momentary contact). This switch can then be used to open, stop or close the door. Install the wall switch in a location where the switch is out of reach of children and the garage door is visible.

- 03 **Set** button (yellow) is used during the installation phase together with the Open and Close buttons to set the door limit positions. The Set button is also used to re-initialize the Opener.

- 04 **Operate** button (Yellow) is used during installation to test the open, stop and close cycles for the opener. The opener has to be initialized by the Reset button before the O/S/C button becomes operable.

- 05 **Plus (+)** button (green) is used during installation to help set the open limit position. Pressing and holding this button will move the door in the open direction. Movement stops when the button is released.

NOTE: The open safety obstruction detection is inoperable whenever the Open or Close Drive button is used to move door.

- 06 **Open limit led** (green) the led is very helpful during installation. It illuminates and flashes when the door is opening and remains steady on when the open limit position has been reached.

- 07 **Force margin set** Button The obstruction force pressure is set automatically by the opener during installation. The pressure can be adjusted manually using the Force Margin Set button (White). Holding the Force Margin Set button and pressing the Plus (+) or Minus (-) button will increase or decrease the amount of force. The Force Margin Set is only ever used if other environmental factors (wind, etc.) effect the operations of the door/opener.

- 08 **Light code** button (white) is used for storing or erasing the transmitter button (code) you wish to use to switch the courtesy light on the opener on or off.

- 09 **Coding led** (red) light flashes when a code is being stored or when a transmitter button is pressed.

- 10 **Door code** button (blue) is used for storing or erasing the transmitter button you wish to use to command the door to open, stop or close.

- 11 **Door status LED** (Yellow)

- 12 **Minus (-)** button (red) is used during installation to help set the close limit position. Pressing and holding this button will move the door in the close direction. Movement stops when the button is released.

NOTE: The close safety obstruction detection is inoperable whenever the Open or Close Drive button is used to move door.

- 13 **Close limit LED** (red) the led is very helpful during installation. It illuminates and flashes when the door is closing and remains steady on when the close limit position has been reached.





Operating controls

- 14 **Datum adjust screw** is used during limits set up to indicate the mid point of the door's travel.
- 15 **Auto close time** button (White) is used to adjust the auto close time. While holding in the auto close button and then pressing the open button the time is increased. Each press will increase the time by 5 seconds. Pressing the close button will decrease the time.
- 16 **Engage/disengagement cord** when pulled down and released this will select manual mode on the opener, particularly when there is a power failure. Pulling down and again releasing will select automatic mode on the opener. The length of the string is adjustable.
- 17 **Easy access transmitter** The "manual release" engage/disengagement handle has within its housing a

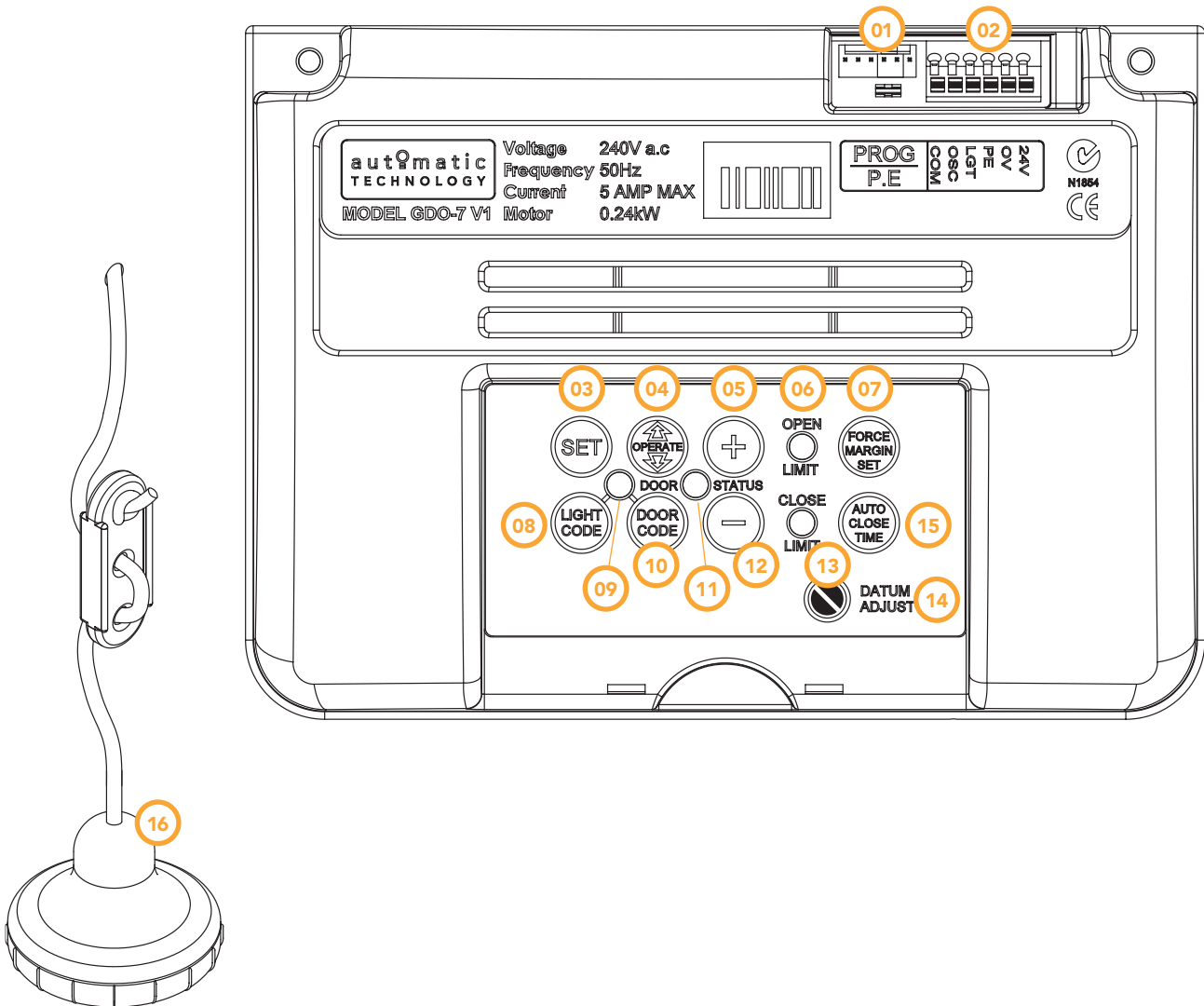



Package contents

GDO-7 Securalift® drive unit	1
Securacode® key ring transmitter pack	1
Pack includes two keyring transmitters two batteries and one wall mount bracket for ptx4 transmitter	
Easy access transmitter - EAT-1 (not available some models)	1
Tubes	5
Tube inserts	4
Pipe support assembly	1
Chain	1
Shuttle assembly	1
Door attachment arms	2
Accessory pack	1
Installation manual	1

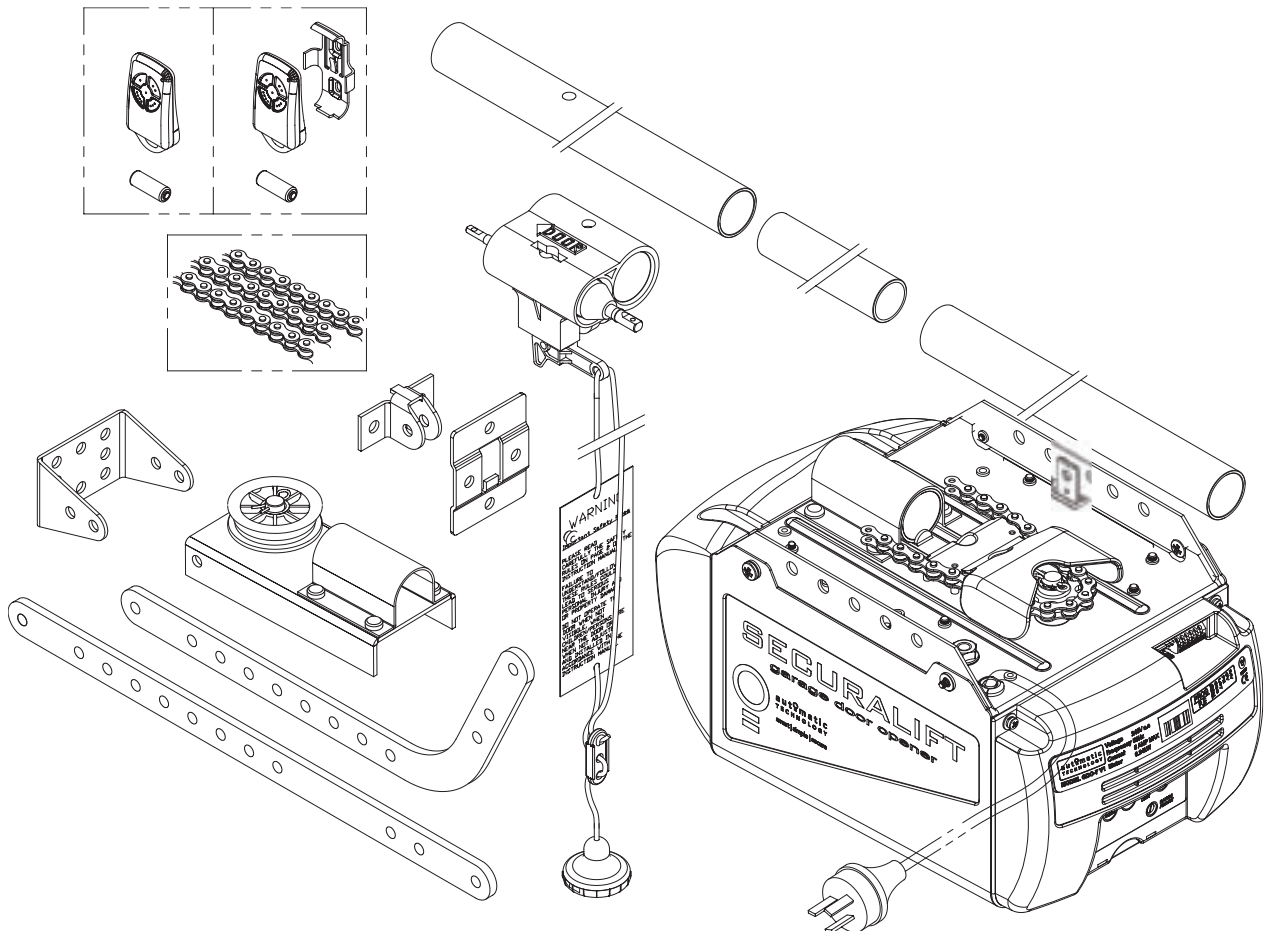



Tube/pipe assembly

IMPORTANT SAFETY INSTRUCTIONS FOR INSTALLATION

**Warning: Incorrect installation can lead to severe injury.
Follow ALL installation instructions.**

Check operation of door before beginning the installation of the securalift® automatic opener check the operation of the door.

Step 1.

Slide shuttle assembly onto tube (one piece only) and locate it in approximately half way position.

PLEASE NOTE: Arrow on shuttle must point towards garage door. To assemble the rest of the tubes, always slide short insert tube half way into the long tube, then slide other tube onto remaining portion of insert tubes. Continue this process with remaining tube until desired length is achieved.

Step 2.

The opener is supplied with an 8 teeth drive sprocket on the drive unit. If the opener is to be fitted to a one piece door without track, exchange the 8 teeth sprocket on drive unit, with a 7 teeth drive sprocket available as an option from Automatic Technology.

Step 3.

Attach one end of chain to chain index screw, nearer to drive unit, using one joint link. (Fig. 1). Proceed to wrap chain around drive unit sprocket and chain spreader, then follow along the pipe to the idler wheel on support pipe assembly, finally attach to the other end of the chain index screw.

NOTE: Make certain that the teeth of the drive sprocket are engaged in the chain and that the chain is not twisted. Make sure that the chain is engaged in the chain spreader and the idle wheel on the support pipe assembly.

Step 4.

Disengage trolley from chain index by swinging lever downward (Fig. 2), then slide trolley away from chain index along pipe track. Loosen locking nuts on chain index screws. To tighten chain, turn chain index in anticlockwise direction, looking from support pipe assembly to drive unit. Do not over-tighten chain as it has to sag 6-12mm. Check before locking screw with locking nuts that chain is not twisted. When the tension is finalized, tighten lock nuts at both ends of chain index.

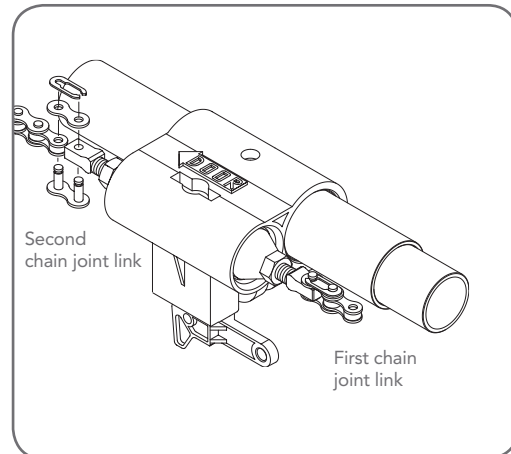

fig 01

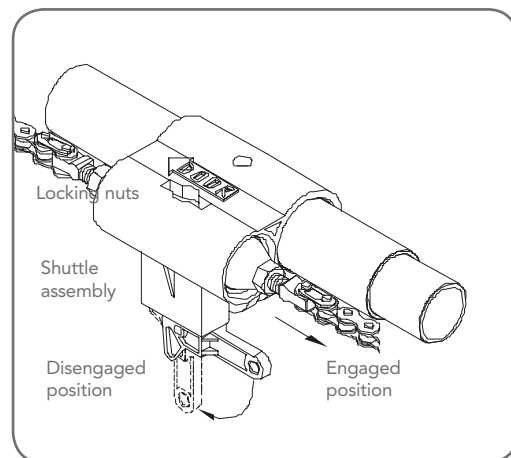

fig 02

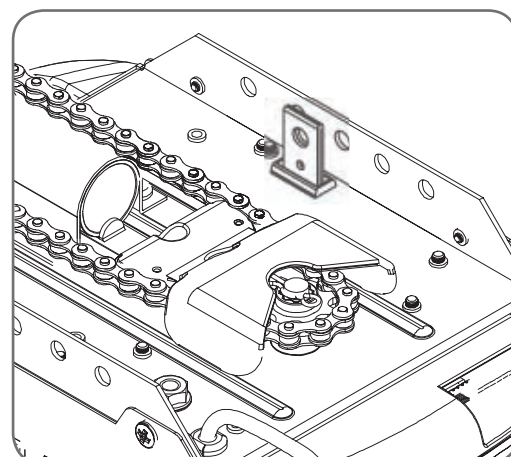

fig 02 a





Determine the door type

fig 03

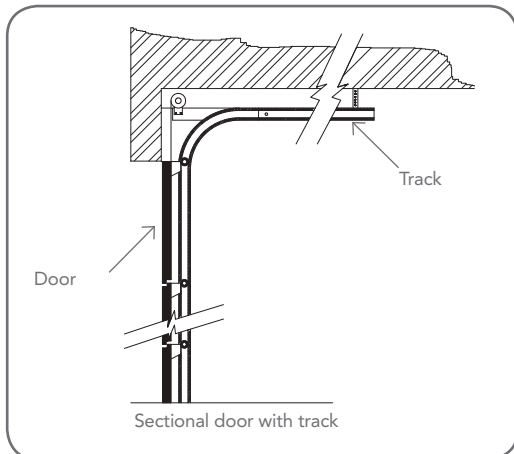

Determine which type of garage door you have as illustrated below. **(Fig. 3 -5)**.

- For a sectional (panel) door on tracks **(Fig. 3)** proceed with the installation from Step 5.
- For a one piece door on tracks **(Fig. 4)** proceed with the installation from Step 5. For a one piece door without tracks (on springs) **(Fig. 5)** proceed with the installation from Step 9.

fig 04

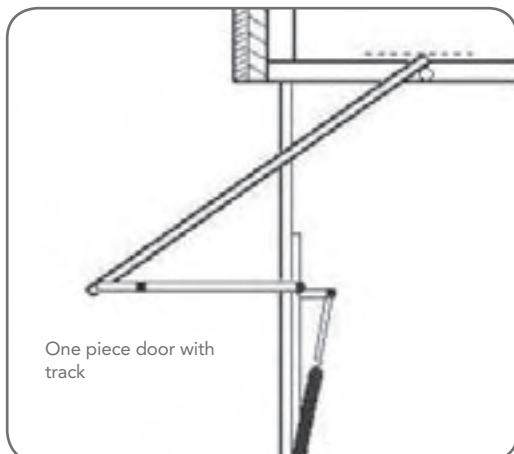
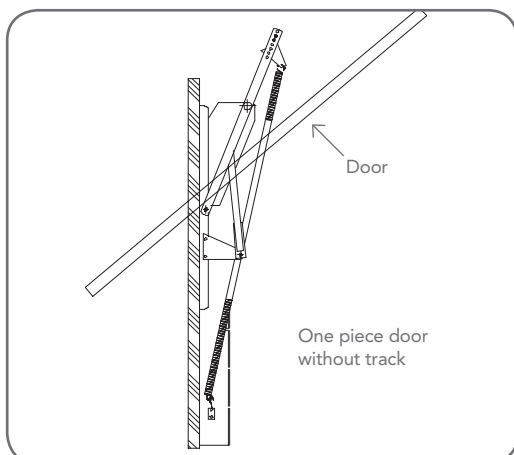

fig 05





Mounting on a track type door

Step 5.

Open the door and find the highest point of travel of the top door panel. Using a level, transfer this height to the wall above the floor (Fig. 6) and mark a line 60mm above it. Determine the centre of the location on the wall above and on top of the door. Then draw two (2) lines 21.5mm on each side of the door centre. (Fig. 7).

Step 6.

The intersection of line at 21.5mm from door centre and line 60mm above highest point of travel are centre points, where holes for mounting of wall bracket should be drilled. (Fig. 7)

If the wall bracket is mounted onto concrete or brick wall, use 8mm or 5/16" loxins or dynabolts. If mounting onto wooden lintel or beam, use wood screw #20 or equivalent minimum 50mm long.



WARNING: make sure concrete, brick wall or timber lintels are solid and sound so as to form a secure mounting platform.

Step 7.

When the wall bracket is firmly secured in its proper position, attach the support pipe assembly to wall bracket with 90 mm long clevis pin and secure with supplied spring clip, (Fig. 8) leaving drive unit in its packing box for protection during installation.

Step 8a. (Method one)

Raise the drive unit from the packing box and support it in a horizontal position with a step ladder, then open the garage door. Rest the opener on the open door and use a scrap piece of wood to bring it to horizontal level. Line up the track with the centre line on top of the door. Secure to the ceiling above drive unit mounting holes, with perforated angle (not supplied). A representative mounting is shown. (Fig. 9)

Connect angle and drive unit with 2 flat perforated strips of angle (not supplied) with M8 x 20mm screws, nuts and washer. Strips should not extend more than 18mm below centre of drive unit mounting holes. (Fig. 9).



WARNING: the opener must be securely fastened to a structural support of the garage. Failure to fasten the operator correctly will lead to possible opener failure causing serious personal injury and/or property damage.

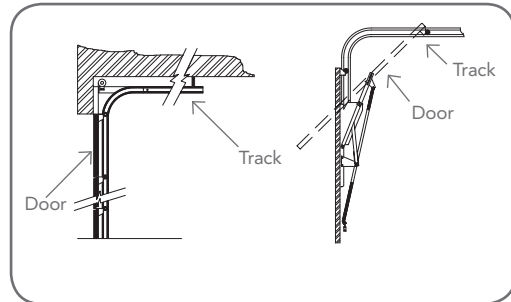

fig 06

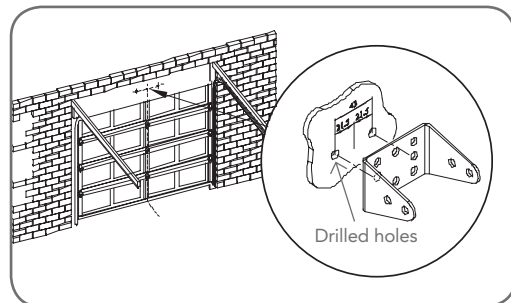

fig 07

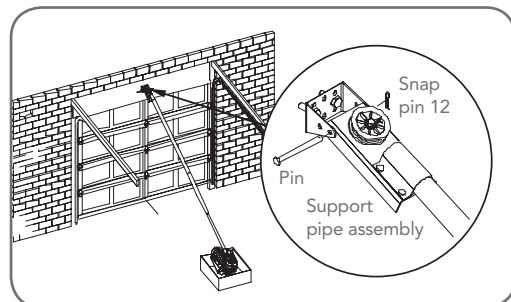

fig 08

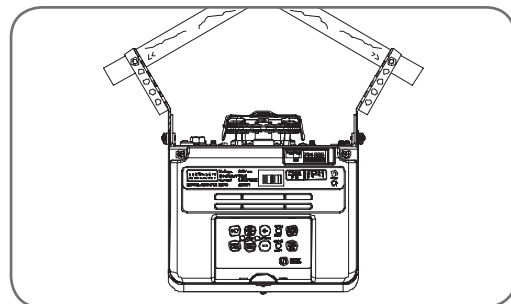
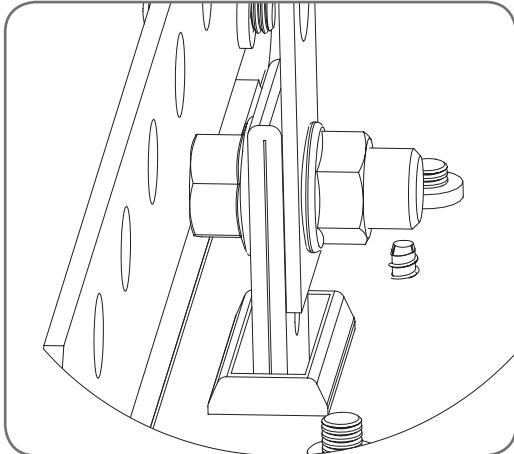

fig 09





Using anti vibration brackets



Step 8b. (Method two)

Raise the drive unit from the packing box and support it in a horizontal position with a step ladder, then open the garage door. Rest the opener on the open door and use a scrap piece of wood to bring it to horizontal level. Line up the track with the centre line on top of the door. Secure to the ceiling above drive unit mounting holes, with perforated angle (not supplied). A representative mounting is shown. **(Fig. 9)** Connect angle and vibration brackets on drive units 2 flat perforated strips of angle (not supplied) Use the M6 X 16 Flanged Head Bolts (2) and M6 Flanged Head Nuts (2) and secure the hanger straps to the anti vibration brackets as per the diagrams. The brackets may have to be pushed lightly on an angle to allow the bolts to **be fitted**. Strips should not extend more than 18mm below centre of drive unit mounting holes. **(Fig. 9)**.

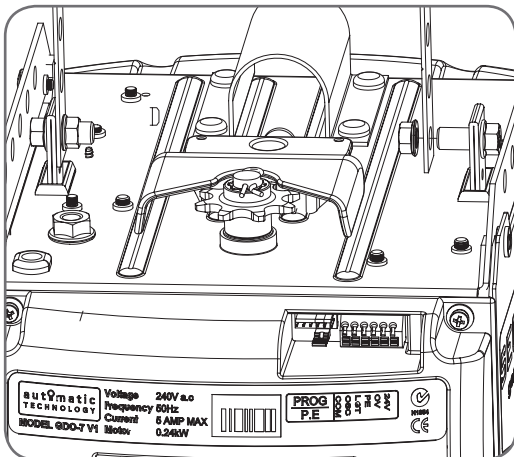

IMPORTANT: Make sure that the head of the M6 bolt is facing the outside edge of the opener so that the threaded part of the bolt does not come into contact with the right angled return running along the edge of the metal chassis..



WARNING: the opener must be securely fastened to a structural support of the garage. Failure to fasten the operator correctly will lead to possible opener failure causing serious personal injury and/or property damage

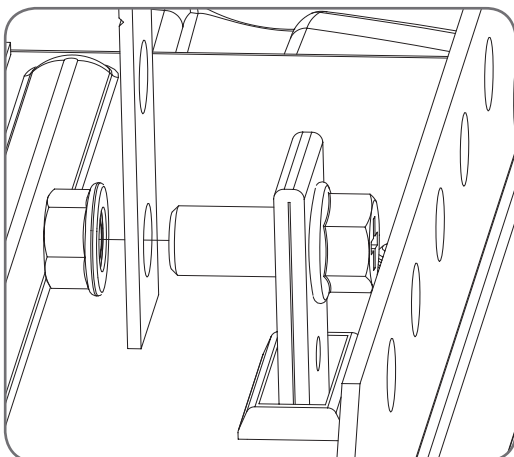



Mounting on a spring loaded door

Step 9.

Determine the centre of the door and mark this location on the wall above and on top of the door. Then draw two (2) lines 21.5mm on each side of the door. (Fig. 10).



WARNING: make sure concrete, brick wall or timber lintels are solid and sound so as to form a secure mounting platform.

Step 10.

Raise the door to open position. Rest the opener on the top edge of the door with end of the pipe/tube against the header wall and drive unit support level with the lowest point of the open door. (Fig. 11).

NOTE: Do not slide opener tube/pipe on face of the door when it is open.

Secure the opener to the ceiling above drive unit mounting holes, with perforated angle (not supplied). A representative mounting is shown. (Fig. 9) Connect angle and drive unit with 2 flat perforated strips of angle (not supplied) with M8 x 20mm screws, nuts and washer. Strips should not extend more than 18mm below centre of drive unit mounting holes. (Fig. 9). Do not lock screws at this stage.

Step 11.

Close the door slowly. The opener pipe/tube will be elevated by the top edge of the door as it moves. Stop the door when it is at its highest point of travel. (Fig. 12) Allow 25mm additional height for clearance between the door and the track. Support pipe / tube in this position and the close the door. (Fig. 12) This will be the height to mount the wall bracket. Top of door must not touch tube.



WARNING: the opener must be securely fastened to a structural support of the garage. Failure to fasten the operator correctly will lead to possible opener failure causing serious personal injury and/or property damage.

Step 12.

With the centre point of the door located, mark a line through the centre of the wall bracket onto the header wall (above the door). Using the bracket as a template mark a minimum of two holes and drill with appropriate size bit. If necessary the wall bracket can be anchored using more than two holes for a more secure fitting. If the wall bracket is mounted onto concrete or brick wall, use M8 or 5/16" loxins or dynabolts. If mounted onto wooden lintel or beam, use wood screws #20 or equivalent, minimum 50mm long. Attach the wall bracket to the support pipe assembly with 90mm long clevis pin (Fig. 13) and securely spring clip.

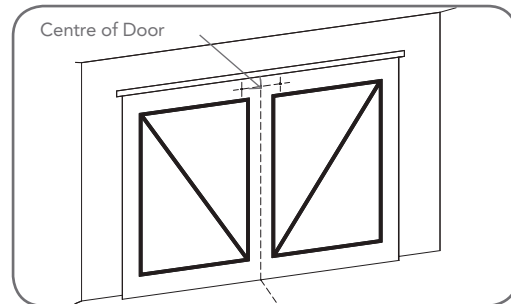

fig 10

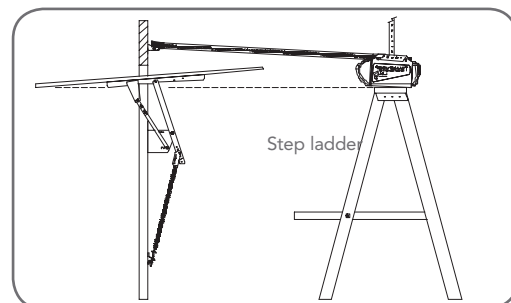

fig 11

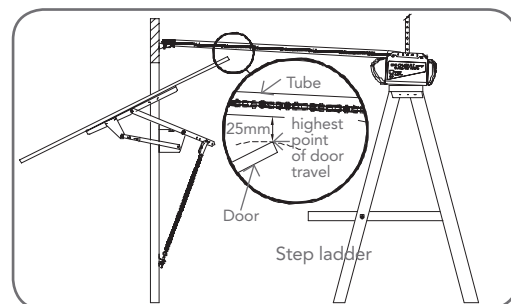

fig 12

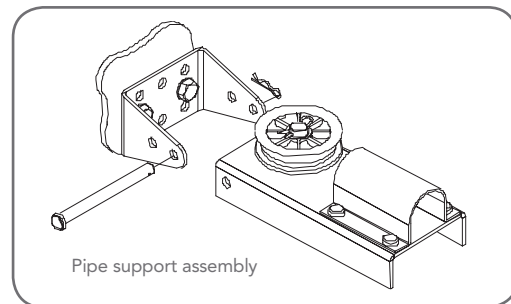
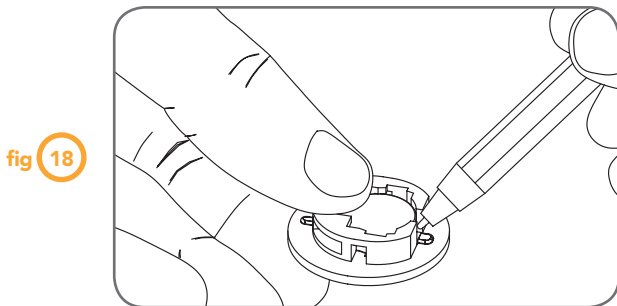
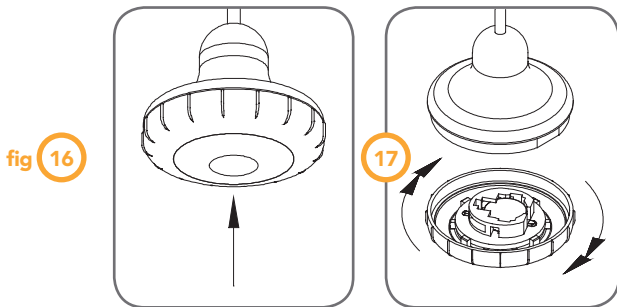
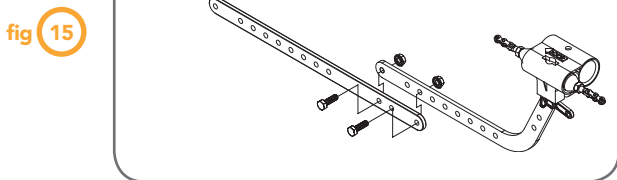
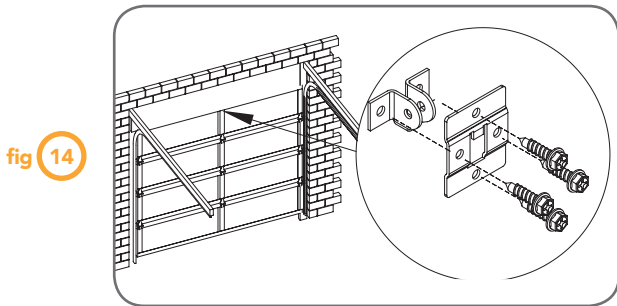

fig 13





Mounting door bracket and arms



Step 13.

The door bracket comes in two parts. The bottom plate with two mounting holes is used on its own for any one piece doors. The top plate is placed over the bottom plate and uses 4 mounting holes for extra strength. This is used on sectional doors. (See **Fig. 14**). Mount the door bracket to the centre line of the door using M6 or equivalent screws (not supplied) Alternatively it can be welded on steel doors.

NOTE: As various types of doors exist, if in doubt about the strength of the door, reinforcement may need to be added to the frame or panel where necessary. Damage to the door panel may occur if the bracket is installed incorrectly on a panel with insufficient strength. The door opener warranty does not cover damage caused by the opener to the door and/or door panel.

Step 14.

Assemble bent and straight arm with screws, and hex nuts supplied in accessory pack. (**Fig. 15**) Then connect assembled arm to the door bracket and the shuttle by clevis pin and spring clip. shuttle must be in disengage position. use the bend & straight arm. If installing on a door with bad wave action, lengthening the arm even further will assist the door operation by reducing the wave action.

The easy access transmitter

The Easy Access Transmitter is prepared ready for use with the battery pre-installed. Before the transmitter can be operational, the Transmitter Code has to be stored into the openers memory. To store the code please follow the instructions in Step 18.1 on page 20.

Removing the cover to replace battery

1. Rotate the cover Clockwise to 'CLOSE'
2. Rotate the cover Anti-clockwise to 'OPEN'

Removing the battery

(Battery Type: 3V Lithium Battery CR1220). Use a non-metallic object (e.g Pen) to remove the battery. (see **Fig. 18**)



WARNING: Metallic objects used to remove the battery may DAMAGE the circuit board or the battery.

Replacing the battery

Place one side of the battery into the battery holder, then press the battery down firmly until it clicks into a flat position.

NOTE: The length of the manual release cord is user adjustable simply by sliding the plastic toggle along the cord to achieve the desired length. Adjust the length of the cord so that it can be easily reached by an adult of average height (ie. less than 1.8m tall).





Setting limits

Step 15. Setting travel limits positions method one: via the control panel

IMPORTANT NOTE: The OPERATE button will not function until the open and close limits positions are set.

15.1. Setting datum position

1. Move the door manually to engage the shuttleassembly onto the chain index.
2. Turn power on - the Close Limit LED should be flashing.
3. Press and hold Minus (-) or Plus (+) button to move the door to half way open position.
4. Using a small blade screw driver turn the datum adjust screw slowly until the yellow status LED just illuminates.

NOTE: If the status LED is already illuminated when the door is half way up then turn the datum adjust screw until the LED goes off then turn back one notch to illuminate again.

15.2. Setting limits positions

NOTE: The door and shuttle must be engaged into the chain index and should be open approximately half way.

1. Press red Minus (-) button and hold it, the door will start closing. Release the button once you have reached your desired closed limit position. (Fig. 21)
2. Press the set button. This action will store into memory the closed limit position.
3. Press the green Plus (+) button, the door will start opening. Release the button once you have reached your desired open limit position.



IMPORTANT WARNING: Please be aware that the garage door will start closing automatically once step 4 is performed. The door will also automatically re-open after fully closing with a small pause between the cycles.

4. Press the Set button. This action will store into memory the door limit position. The door will now automatically close to its limit position then fully open to calculate the safety obstruction forces (ISS). Please be aware of the above warning.

The opener can now be operated via the operate button.



WARNING: DO NOT TURN DATUM ADJUST SCREW AFTER LIMIT SETTING, OTHERWISE OPENER WILL NOT FUNCTION CORRECTLY.

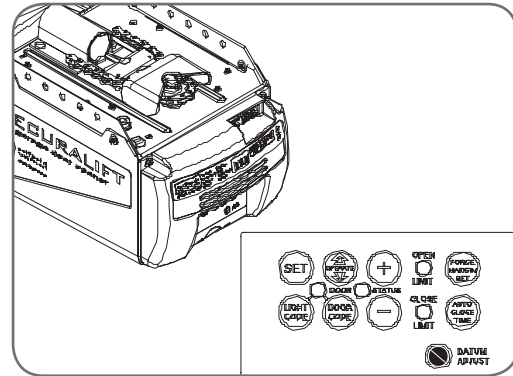

fig 19

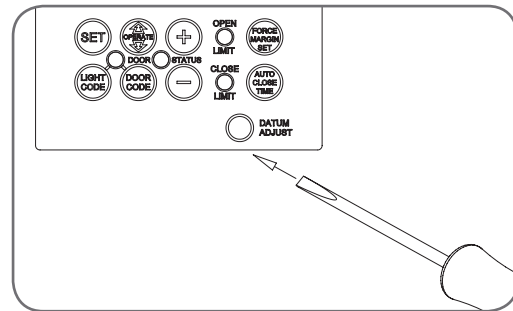

fig 20

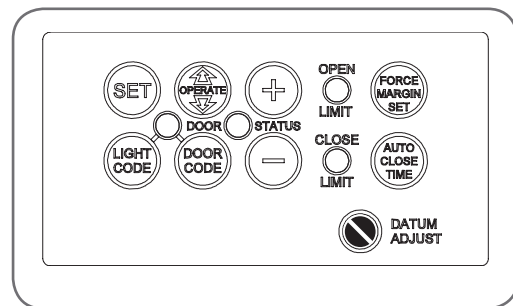

fig 21

15.3. Resetting door limit positions

The door travel limit positions can be deleted for new positions by the following steps below:

1. Press and hold the Close button (Fig. 21) for six (6) seconds until you hear three beeps and the red Close Limit LED starts to flash. Release the button.
2. Follow STEPS 15.1 and 15.2 to set new travel limit positions.

Go to STEP 17 and test the Safety Obstruction Force.





Setting limits

fig 22

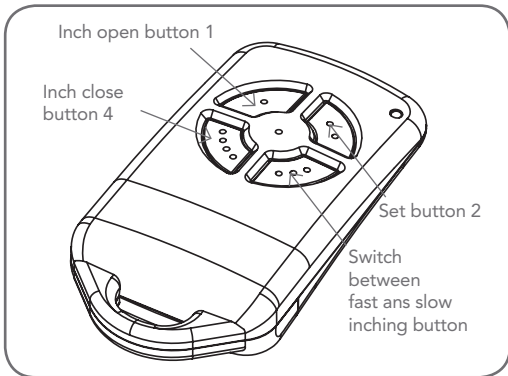

fig 23

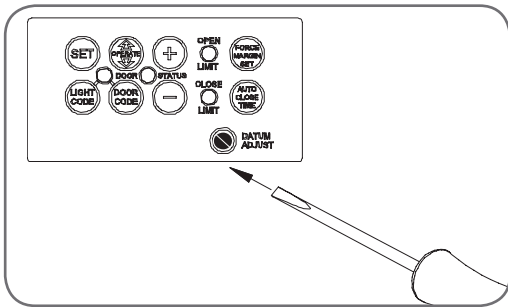
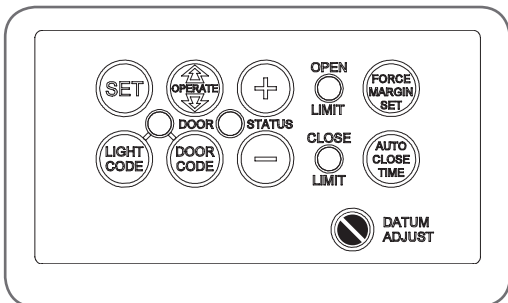

fig 24



Step 16. Setting travel limit positions method two: via the transmitter

IMPORTANT NOTE: The OPERATE button will not function until the open and close limits positions are set.

16.1. Setting datum position

1. Move the door manually to engage the shuttle assembly onto the chain index.
2. Turn power on - the Close Limit LED should be flashing.
3. Press and hold Minus (-) or Plus (+) button to move the door to half way open position.
4. Using a small blade screw driver turn the datum adjust screw slowly until the yellow status LED just illuminates.

NOTE: If the status LED is already illuminated when the door is half way up then turn the datum adjust screw until the LED goes off then turn back one notch to illuminate again.

16.2. Coding transmitter for setting limits

1. Press and hold the Door Code button (Fig. 24).
2. Press button 1 on the transmitter for two seconds. Release and pause for two seconds. Press the same button again on the transmitter for two seconds.
3. Release Door Code button.

16.3. Setting limits

NOTE: The door and shuttle must be engaged into the chain index and the door should be open approximately half way.

1. Press button 4 (Fig. 22), the door will start closing, release the button once you are 1 to 2 cm from your desired closed limit position. Press button 3 for two seconds then release.
2. Press button 4, each press will enable you to fine inch the door to your desired closed position.
3. Once you are happy with the position press button 2, this action will store into memory the closed limit position.
4. Press button 1, the door will start opening. Release the button once you are 1 to 2 cm from your desired open limit position. Press button 3 for two seconds then release.
5. Press button 1. Each press will enable you to fine inch the door to your desired open position.



IMPORTANT WARNING: Please be aware that the garage door will start closing automatically once step 6 is performed. The door will also automatically re-open after fully closing with a small pause between the cycles.

6. Once you are happy with the position press button 2, this action will store into memory the door limit position. The door will now automatically close to its limit position then fully open to calculate the safety obstruction forces (ISS). Please be aware of the above warning.

16.4. Resetting door limits positions

The door travel limit positions can be deleted for new positions by the following below:

1. Press and hold the Minus (-) button (Fig. 24) for six (6) seconds until you hear three beeps and the red Close Limit LED starts to flash. Release the button.
2. Follow STEP 16.1 and 16.3 to set new travel limit

IMPORTANT: There is no need to re-code the transmitter used for setting the limit positions. After the limits are set the transmitter automatically resets to normal operation.

Go to STEP 17 and test the Safety Obstruction Force.





Setting safety obstruction force

Step 17. Safety obstruction test

Please take care when testing the Safety Obstruction Force. Excessive force may cause **SERIOUS PERSONAL INJURY** and/or **PROPERTY DAMAGE** can result from failure to follow this warning.

17.1. Testing close cycle

1. Open the door by pressing the Yellow Operate button (Fig. 25).
2. Place a length of timber approximately 50mm high on the floor directly under the door (Fig. 25a).
3. Press the Operate button to close door. The door should strike the object and start to re-open.

17.2. Testing open cycle

1. Close the door by pressing the Operate button.
2. Press again to open the door. When the door reaches half the opening distance, grab the bottom rail of the door firmly, the door should stop. If the door does not reverse readily when closing, or stop when opening, the force may be excessive and need adjusting, refer to STEP 17.4.



IMPORTANT WARNING: If the door is closing and is unable to re-open when obstructed, discontinue use. Do not use a door with faulty obstruction sensing. Repair fault and re-test before using.

Adjusting safety obstruction force

The Safety Obstruction Force is calculated automatically and set in memory on the SecuraLift® opener. It is usually not necessary to adjust the Safety Obstruction Force. The only time the force may need to be increased is due to environmental conditions, for example, windy or dusty areas, and areas with extreme temperature changes.

17.3. To increase force pressure

1. Press and hold the Force Margin Set button (Fig. 25)
2. While holding down the Force Margin button, press the Plus (+) button. Each press increases the force margin. The Open Limit LED will flash each time the Plus button is pressed to indicate an increase in force. Test the force again as per step 17.1 and 17.2 above. If the Open Limit LED flashes continuously when the Plus button is being pressed, this indicates that the maximum force pressure setting has been reached.

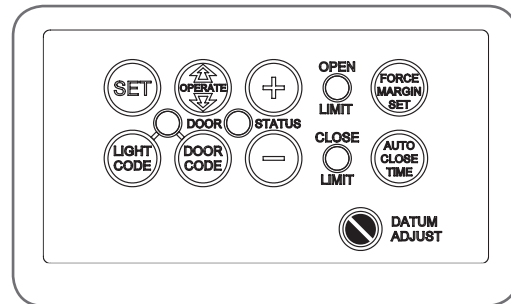

fig 25

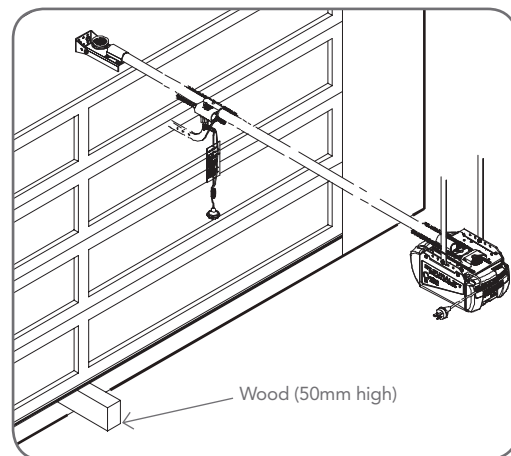

fig 25 a

17.4. To decrease force pressure

1. Press and hold the Force Margin Set button (Fig. 25).
2. While holding down the Force Margin button, press the Minus (-) button. Each press decreases the force margin. The Close Limit LED will flash each time the Minus button is pressed. Test the force again as per step 17.1 and 17.2 above. If the Close Limit LED flashes continuously when the Minus button is being pressed, this indicates that the maximum force pressure setting has been reached.

17.5. To recall factory set force

1. While holding down the Force Margin Set button, press the SET button (Fig. 22) for two seconds.
2. Release both buttons. The default setting should now be recalled.





Coding transmitters

fig 26

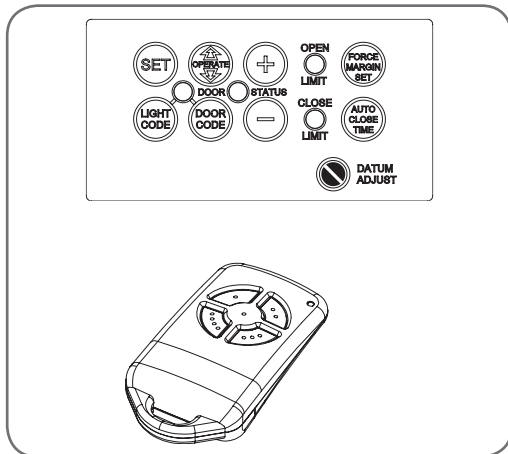

Step 18. Setting transmitters codes

Make sure to connect the battery to the transmitters. The memory in the openers receiver can store up to 24 different remote control transmitters.

18.1. Storing the transmitters code

1. Press and hold the Door Code button (**Fig. 26**).
2. Press the button (one of four) on the transmitter you would like to use to control the door for two seconds, pause for two seconds. Press the same button again on the transmitter for two seconds.
3. Release the Door Code button.
4. Press the transmitter button to test if it operates the door.

18.2. Setting the transmitter to operate the courtesy light

The transmitter can be programmed to operate the courtesy light on the door opener.

1. Press and hold Light Code button (**Fig. 26**).
2. Press the button on the transmitter you would like to use to switch on the light for two seconds, pause for two seconds. Press the same button again on the transmitter for two seconds.
3. Release all buttons to store the transmitter in memory.
4. Press the transmitter button to test if it switches on the light.

18.3. Setting the transmitter to operate pet (pedestrian) mode

1. Press and hold Door Code button and the Close button (**Fig. 26**).
2. Press the button on the transmitter you would like to use to control pedestrian mode for two seconds, pause for two seconds. Press the same button again on the transmitter for two seconds.
3. Release all buttons to store the transmitter in memory.
4. Press the transmitter button to test if it operates the pedestrian mode To change the default pet (pedestrian) door opening position, refer step 24 on page 19.

18.4. Setting the transmitter to operate vacation mode

1. Press and hold Light Code button and the Close button (**Fig. 26**).
2. Press the button on the transmitter you would like to use to control vacation mode for two seconds, pause for two seconds. Press the same button again on the transmitter for two seconds.
3. Release all buttons to store the transmitter in memory.
4. To test, press and hold the transmitter button set for vacation mode for five seconds to set Vacation Mode.

To reset Vacation Mode press the same button for two seconds. Please note that when vacation mode is activated all stored transmitters will be locked out. This mode can only be deactivated by a transmitter which has been stored to activate this mode.



Coding transmitters

Step 19. Storing transmitter(s) from a remote location

Using this method you don't need to have access to the control panel on the Door Opener. However, you do need a transmitter that is pre coded to the controller's receiver.

IMPORTANT NOTE: The Door or Courtesy Light must be activated when the step below is performed. The moving Door or Light switching on is to confirm from a remote location that, the correct button was pressed, and the transmitter is in range of the Opener.

1. Take any pre-coded transmitter. Press the button for the function you require until the door is activated and release.
2. Then using a small needle press and hold firmly for two seconds through the Coding Hole (**Fig. 27**)
3. Within 10 seconds take the additional transmitter you wish to code.
4. Press the button (one of four) on that transmitter you would like to use to control the door for two seconds, pause for two seconds. Press the same button again on the transmitter for two seconds, the button should now be recorded.
5. Wait for 10 seconds and then press the recorded transmitter button to see if it operates the door.

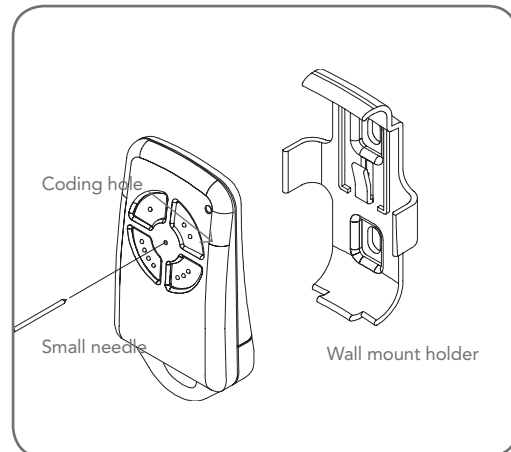

fig 27

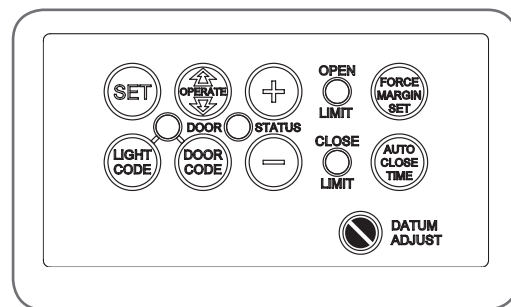

fig 28

20. Deleting programmed codes

20.1. Deleting a stored transmitter code

1. Select the transmitter you want to delete.
2. Press and hold the Door Code button (**Fig. 28**).
3. Press the transmitter button you would like to delete for two seconds. Pause for two seconds. Press the transmitter button again for two seconds.
4. Release the Door Code button. The code should now be deleted. Confirm this by pressing the transmitter button, the door should not respond.

20.2. Deleting all stored transmitters

1. Turn the Power Off to the Opener.
2. Press and hold the Door Code button (**Fig. 28**).
3. Turn the Power On again, while holding the Door Code button. The Open Limit, Close Limit and Door Status LED's will illuminate for about five seconds. These LED's will turn Off and the Coding LED will illuminate. Release the Door Code button. All the stored codes including the Courtesy Light codes should now be deleted. Confirm this by trying to operate the door by pressing the transmitters previously used to control the door, the door should not respond.





P.E. Beam and auto close

fig 29

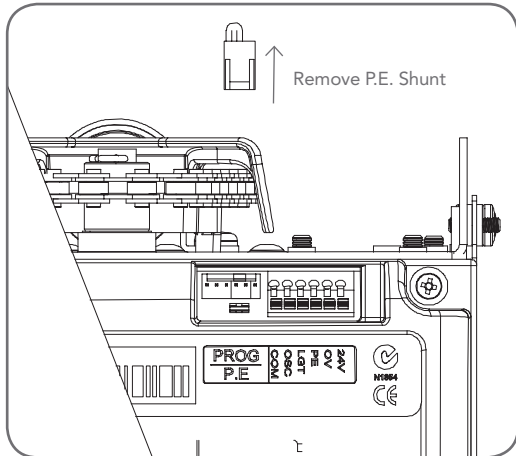

21. Fitting the safety photo electric beam sensor (optional)

Locate the Photo Electric Beam (P.E.) normally closed contact type in a strategic location within doorway. We recommend 150mm above the floor level and as close as possible to the door opening, inside the garage. Remove shunt from P.E connector (Fig. 29) and connect the wires from the P.E. wiring harness to terminal block (Fig. 30). The wiring diagram is for Model PHBE (Order Code 90214).

Make sure to align the beams correctly. Follow the manual supplied with the Photo Electric Beam.



WARNING: When using Auto Close Mode and P.E. beams, the doorway must be clear of all obstructions and persons at all times. The location of the beam and manner in which it is installed might not give safety protection at all times. Check to make sure that the height of the beam and type used give maximum protection possible.

fig 29

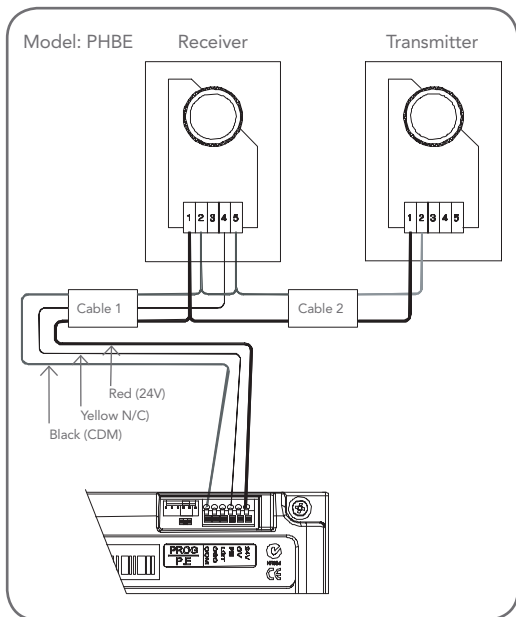

22. Setting of auto close time important notice: it is compulsory to install a photo electric beam before using the auto close mode.

The Auto Close timer will only start after the Photo Electric Beams (P.E.) path is broken and the auto close time has been set. If the P.E. path is not broken the door will remain open till the path is broken. If the Door Opener incurs an obstruction (not from the P.E.) while closing the door will re-open and not auto close until the part of the P.E. beam is broken again.

Setting auto close time

1. Press and hold the Auto Close Time button (Fig. 31).
2. While holding in the Auto Close Time button, press the Plus (+) button. Each press of this button will add one second to the auto close delay time.
3. To decrease the delay time follow Step 1 and press the Minus (-) button. Each press will deduct one second from the auto close time.
4. Press the Operate button or transmitter to open the door. When the door is fully opened the Open Limit green LED will flash to indicate that the auto close mode is in operation. Break the path of the P.E. Beam momentarily, this will initialize the auto close mode. When the door reaches the fully opened position, the door will pause for the set auto close time and start to auto close.

fig 29

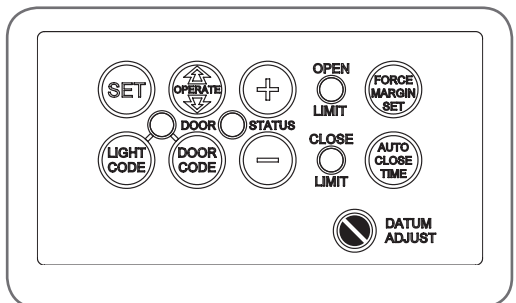



Final set up

23. Setting of courtesy light time

The preset courtesy light time on the door opener is 3 minutes. This time can be changed by the following:

1. Press in and hold both the Auto Close Time button and Force Margin Set button (**Fig. 32**).
2. While holding in the two buttons, press the Plus (+) button. Each press of the button will add 10 seconds to the light time.
3. To decrease the time follow Step 1 and press the Minus (-) button. Each press will deduct 10 seconds from the light time.
4. To recall the factory set default light time press in and hold together the Auto Close Time button, the Force Margin Set button and the Set button for about 2 seconds. Release all buttons, the factory set default of 3 minutes will be recalled.

24. Setting the pet mode door opening position.

The default PET (Pedestrian) position is factory preset to a predetermined height. The PET mode status is indicated by both the Open and Close Limit LED's being illuminated. The default position can be changed by the following:

1. Make sure the door is in the closed position. Press and hold the Plus (+) button for six (6) seconds (**Fig. 32**), you should hear three beeps and the Open and Close LEDs will flash rapidly.
2. Press the Plus (+) or Minus (-) button (**Fig. 32**) to move the door to your required new pet open door position.
3. Press the Set button (**Fig. 32**) to record the new position.

The Pet mode is activated from a transmitter button coded to that function. When activated the door drives to the preset position from either above or below. If the Pet button is pressed while the door is moving the door will be stopped. If the Pet button is pressed when the door is in the Pet position, then the door will be closed. No auto close is enabled.

25. Installation of wall mounted transmitter holder

1. Mount the holder in a location out of reach of children and convenient to the customer. (**Fig 33**). Make sure the door is visible from this location.
2. The transmitter can be easily clipped in and removed from the holder as required.
3. To set the transmitter codes refer to Step 18 on Page 20.

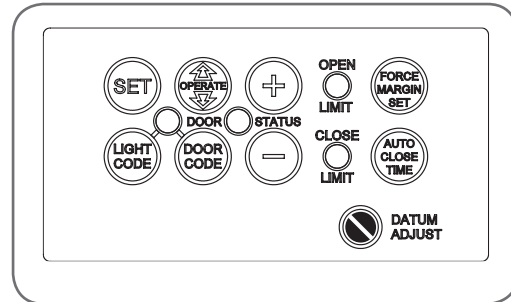

fig 32

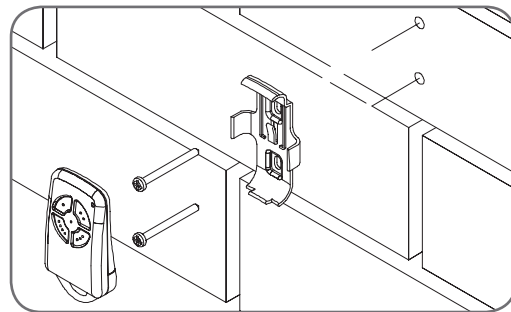

fig 33

26. Re-initializing the opener

To re-initialize the opener press and hold the Set Button for two (2) seconds, the beeper will sound once. The door will start to move and re-calculate force margins. The door can move between the open and close limit positions up to four (4) times (depending on the position of the door and the power up condition). A single beep will be heard once the initialization is complete. The door is now ready for use.





Parameters

Door Status Indicators

Door Opener State	Open LED Green	Close LED Red	Door Status LED yellow	Beeper
Open	On			
Close		On		
Opening	Flashing			
Closing		Flashing		
Door travel stopped	Flashing			
Door obstructed when opening	Flashing			
Door obstructed when closing		Flashing		Beeps while door is moving
Opener overloaded	Alternating flashes	Alternating flashes		
Door in open position with auto close mode selected	One second flashes			
Mains power interrupted	Rapid flashes			



Parameters

Door Status Indicators

Buttons	Function
Operate	Opens/Stops/Closes the door
Door code	Codes a transmitter button for operate function
Light code	Codes a transmitter button for light function
Door code & Minus (-)	Codes a transmitter button for pet (pedestrian function)
Light code & Minus (-)	Codes a transmitter button for vacation function
Force Margin Set & Plus (+)	Increases the obstruction force margin setting
Force Margin Set & Minus (-)	Decreases the obstruction force margin setting
Force Margin Set (then) Set	Reloads the factory set default obstruction force margin setting
Auto close time (then) Plus (+)	Increases the auto close delay time
Auto Close Time (then) Minus (-)	Decreases the auto close delay time
Auto Close Time (then) Set	Reloads the factory set default auto close delay time
Force Margin Set & Auto Close Time (then) Plus (+)	Each press of the open button increases the light time by 10 secs.
Force Margin Set & Auto Close Time (then) Minus (-)	Each press of the open button decreases the light time by 10 secs.
Force Margin Set & Auto Close Time (then) Set	Reloads the factory default light time
Minus (-) (for 6 secs.)	Clears the door limits set positions. Limits then need to be reset
Set & close (for 2 secs.)	Enters pet (pedestrian) position mode
Set (then power on) & hold until all LEDs are off	Deletes control parameters excluding transmitter storage memory
Door Code (then power on) & hold until all LEDs are off	Deletes all transmitter storage memory
Set & Door Code (the power on) and hold until all LEDs are off	Deletes all control parameters and transmitter storage memory.
Set	Re-initialises the Opener to re-calculate force margin





Default settings and specifications

Factory Default Settings

	Default	Step	Maximum
Maximum motor run time	30 secs	-	-
Courtesy light time	4 mins	10 secs	10 mins
Obstruction force margin	3	1	27
Auto close time	0 secs	5 secs	4 mins





System specifications

Technical Specifications

Maximum residential overhead garage door area	16.5m ²
Door Load	Door Load Rated Load: 150N (15kg) Push pull force 600N (60kg) Short term peak load 700N (70kg)
Supply voltage:	230 - 240 V AC 50Hz
Motor type	1/3 H.P. (AC) Alternating Current
Current	Max 5A
Globe	Edison (screw mount) 240V 60W Rough Service (or construction type)
Limit adjustment	Electronic - semi-automatic
Force control	fully automatic. Can be adjusted for environmental reasons
Transmitter frequency	433.92MHz
Powerhead weight	7.75kg
Max. Opener Run Time	30 secs
Transmitter Code Storage Capacity	24 x 4 button transmitters
Code type	Hopping code
No. of code combinations:	Over 4.29 billion random codes
PTX-4 transmitter battery:	A23 Alkaline 12 Volts
EAT-1 Transmitter Battery	CR1220 Lithium 3 Volts

NOTE:

1. The maximum door opening on which the SecuraLift® can be installed is 6000mm wide by 2400mm high or with an optional extension kit - 5500mm wide by 2700mm high. Door surface area must not exceed 15m². The door must be well balanced. A person should be able to lift the door up manually with very little effort in case of an emergency.
2. Intermittent operations may occur in areas which experience very strong winds. Strong wind puts extra pressure on the door and tracks which may in turn trigger the safety obstruction detection system intermittently.





Trouble shooting

Symptom	Possible cause	Remedy
Door will not operate	Mains power not switched on. Door is obstructed. Door is locked or motor jammed. Door tracks/hardware damaged. The opener is in "vacation mode"	Switch on mains power. Remove obstruction. Unlock door or remove jam. Door requires service/repair by qualified technician. Turn off "vacation mode".
Door starts to close but automatically reverses to open position	Adverse weather conditions (wind or cold) causing door to stiffen and become tight in the tracks. Possible obstruction in the doorway.	Increase force margin setting See Step 17 on page 19. Or re-calculate force margin. Remove obstruction.
Door operates from drive unit (OPERATE) button but not from transmitter* See note	Transmitter code not stored in memory. Flat battery. Broken battery lead inside transmitter	Code transmitter in to openers memory. Refer step 18.1 on page 20 Replace battery - A23 Alkaline 12V. Send transmitter to installer or ATA for repair
Door will not close fully.	Door limits positions need to be reset.	Reset limits positions. Step 15, page 17.
Door will not open fully.	Door limits positions need to be reset.	Reset limits positions. Step 15, page 17.
Courtesy light not working	Globe down	Relace globe - Edison type 240V 60W
Globe keeps blowing	Incorrect globe voltage - must be 240V AC	Relace globe - Edison type 240V 60W
Auto close not working	PE Beam or wiring faulty. PE Beam not aligned correctly. PE Beam is obstructed. Door obstructed when closing. Auto close time not set. Auto close mode not set	Repair PE Beam or replace wiring. Re-align optics. Remove obstruction from path of PE. Remove obstruction. See step 22 on page 22. See step 22 on page 22.

PLEASE NOTE:

Some areas may be prone to excessive radio interference brought on by devices such as cordless telephones, wireless stereo headphones and baby monitors. It is possible that these devices could cause a degree of interference such as to greatly reduce the range of the transmitter. In such an instance please contact your ATA dealer for an alternative frequency replacement kit. As this is not a warrantable situation but an environmental issue charges may apply for the change-over.





Maintenance record

Record any maintenance in the following table to assist in any warranty service.

Date	Maintenance performed by	Signature	Amount	Invoice No.



Spare parts list

When ordering spare parts please quote the order code Number to your installer/dealer

Item/description	order code	Item/description	order code
1 Base plate sub assembly	02152	38 Pan serration head screw m4x12	10380
2 Bush 127id 18	04261	39 Pan head screw w/washer m4x10	10340
3 Ac motor it 0.24Kw	14423	40 Pan head screw m3x14	10360
4 Sel-lock pin spring acp m4x20	02590	41 Internal tooth lock washer i.D.3	11150
5 Label thermally protected	13620	42 Cover assy gdo-7	01599
6 Cover protection	13790	43 Light diffuser	13902
7 Hex nut w/int tooth washer m5	10881	44 Taptite screw 'p' black m3.5X6	10542
8 Label 240v 60 watt gdo-2	13630	45 Pan head screw w/washer m4x8	10320
9 Motor bracket gdo-7	13776	46 Chain joint link	02950
10 Bush 127 17-10	04271	47 Shuttle assembly	00273
11 Bush id 10x10	04290	48 Secura ptx-4 & wall switch pack	01220
12 Worm 2520 2s-st	04932	49 Transmitter grey buttons ptx-4	01210
13 Chopper wheel gdo-7	04951	50 Transmitter red buttons ptx-4	01211
14 Chopper clip	04960	51 Ptx holder	05196
15 Board housing sub assy	01586	52 Alkaline battery a23 12v	13030
16 Control board cb-18 v1	01020	53 Plastic wall plug pack	01479
17 Board shield	14053	54 Clevis pin diameter 8	02550
18 Taptite screw 'p' m4x8	10580	55 Pin	05790
19 Power cord 1.5M w 2pin+1 ring	14150	56 Hex head screw m8x25	10110
20 Easy access transmitter pack	01236	57 Hex serration flange nut m8	10148
21 Controls lid	05108	58 Wall bracket	02521
22 Cord grip grommet sbr5-2	05605	59 Door bracket	02511
23 Lamp holder ls 204-1	05761	60 Door bracket locator	02515
24 Terminal block 500/02ds 2 pos	05421	61 Support pipe cx assembly	00292
25 Harness assy cb-7 (not shown)	14441	62 Chain 1/2"x1/8" (499 links) w/2 cl	03000
26 Cap polyfilm 0.1 Uf k x2 275 vac	07575	63 Tube 338605	13801
27 Terminal block shield	14056	64 Index tube 338605	13811
28 Drive shaft q-c	04542	65 Tube-insert 2970	13830
29 Helical gear 34209	04941	66 Bent arm	02800
30 Sprocket 8t octagonal	04685	67 Straight arm	02790
31 Cap motor 15.0 Uf 44o vac 3k hr	14402	68 Ratchet timing assembly	01737
32 Chain idle wheel	02962	69 Sensor assembly	01689
33 Snap pin ssp 8 znu 31080	10720	70 Taptite screw 'p' m3x12	10553
34 Snap pin ssp 12 znu 31120	10730	71 Vibration isolator	02530
35 Cable clamp acc-15 (3/16")	11750	72 Pan head screw w/washer m4x10	10340
36 Globe 250v 60w	14120	73 Shoulder screw 5-m4x9l	10601
37 Pan head screw w/washer m5x10	10281	74 Grommet 5.2X8.0X4.5	05604



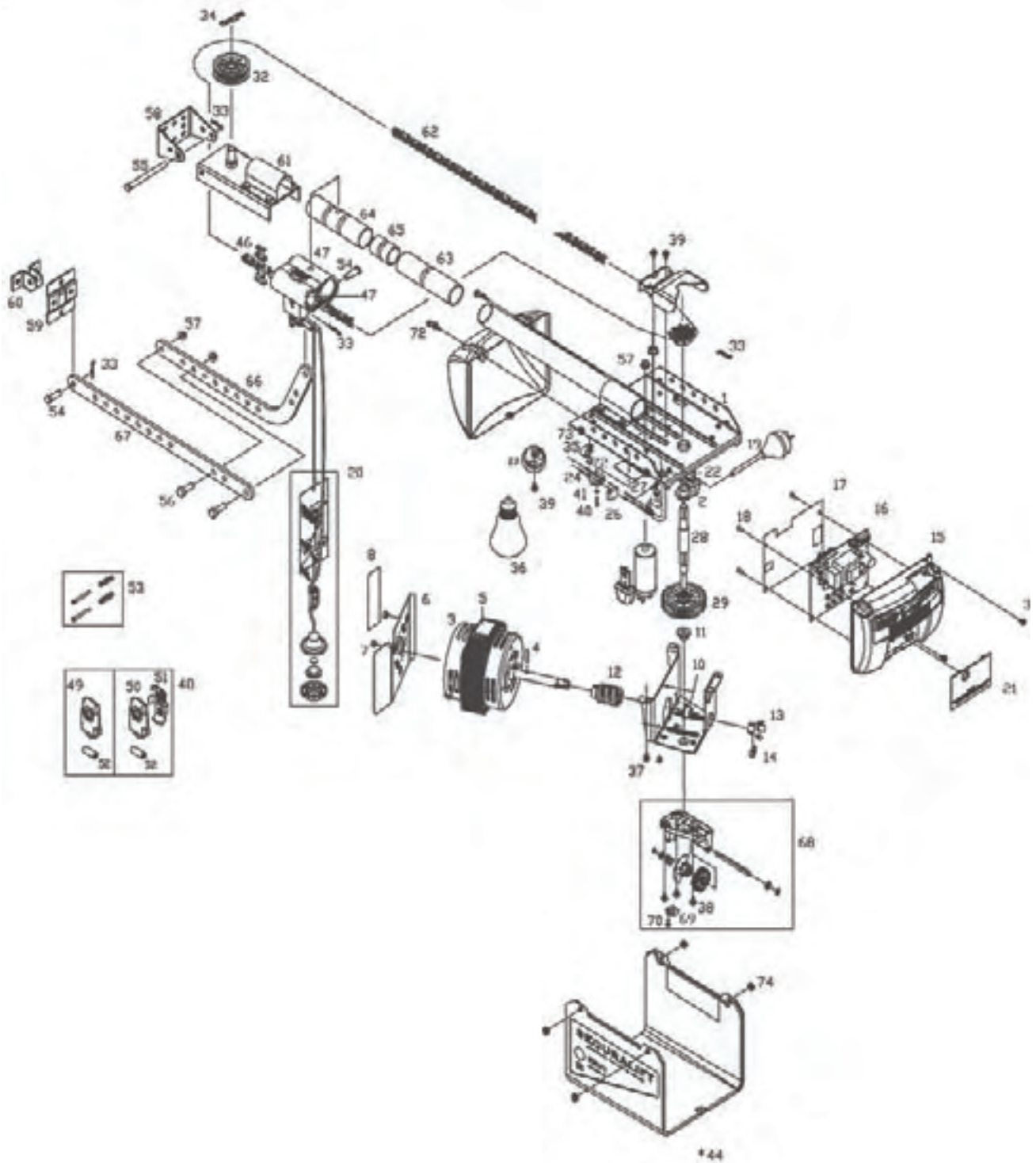



Warranty and exclusion of liability

1. This warranty is an addition to any non-excludable conditions or warranties that are implied into this contract by relevant statute, including the Trade Practices Act 1974 (Cth).
2. Subject to all of the matters set out below, Automatic Technology Australia Pty Ltd ("ATA") warrants:
 - (a) swing and sliding gate opener drive units for twelve (12) months or 2500 cycles, whichever occurs first;
 - (b) roll-up and overhead door opener drive units for twenty four (24) months or 5000 cycles, whichever occurs first; and
 - (c) all components and accessories for twelve (12) months, from the date of purchase (specified in the sales docket receipt) as free of any defects in material and workmanship.
3. This warranty applies only where the purchaser:
 - (a) immediately notifies ATA or the retailer of the alleged defect;
 - (b) returns the product to the retailer; and
 - (c) presents the relevant sales docket and this warranty document to the retailer to confirm the date of purchase.
4. Except for this warranty, ATA gives no warranties of any kind whatsoever (whether express or implied), in relation to the product, and all warranties of whatsoever kind relating to the product are, to the extent permissible by statute, hereby excluded.
5. To the extent permissible by statute, ATA disclaims any liability of whatsoever nature in respect of any claim or demand for loss or damage which arises out of:
 - a) accidental damage to or normal wear and tear to the product or to the product's components;
 - b) any cost relating to damage resulting from wear and tear;
 - c) blown fuses, loss or damage caused by electrical surges, power surges or power spikes;
 - d) loss or damage due to theft, fire, flood, rain, water, lightning, storms or any other acts of God;
 - e) maximum continuous operating time exceeding one (1) minute in ten (10);
 - f) maximum operating force exceeding 15Kg (150N) when moving the door or gate manually to the open or closed position;
 - g) door surface area and/or weight exceeding 15m² and 100Kg respectively;
 - h) residential gate weight exceeding 400Kg;
 - i) door or gate not in safe and correct working order and condition;
 - j) evidence of unauthorised repairs;
 - k) any cost relating to damage caused by misuse, negligence or failure to maintain the equipment in a proper working order as per clauses (d) through (i);
 - l) installation, adjustment or use which is not in accordance with the instructions set out in installation instruction manual
 - m) attempted or complete modification or repairs to the product carried out by a person who is not authorised or has not been trained by ATA to carry out such modification or repairs;
 - n) faulty or unsuitable wiring of structure to which the product is fixed or connected;
 - o) radio (including citizen band transmission) or any electrical interference;
 - p) damage caused by insects;
 - q) loss or damage to any property whatsoever or any loss or expense whatsoever resulting or arising there from or any consequential loss;
 - r) any cost or expense arising due to manufacturer recall of any product;
 - s) any cost or expense due to negligence of the approved service provider;
 - t) installation of a residential garage door or gate opener in a commercial or industrial situation or a non-single residential dwelling.





Warranty and exclusion of liability

6. ATA's liability under this warranty is limited, at ATA's absolute option, to replacing or repairing the product which ATA, in its unfettered opinion, considers to be defective either in material and/or workmanship or to credit the dealer with the price at which the product was purchased by the dealer.
7. This warranty does not extend to cover labour for installation.
8. This warranty is limited to Return-to-Base (RTB) repair and does not cover labour for on-site attendance.
9. This warranty is void if the Product is not returned to the manufacturer in original or suitably secure packaging.
10. This warranty is only applicable for repairs to the product carried out within Australia.
11. This warranty does not cover consumable items including globes, batteries and fuses.
12. This warranty is not transferable.
13. Where the Product is retailed by any person other than ATA, except for the warranty set out above, such person has no authority from ATA to give any warranty or guarantee on ATA's behalf in addition to the warranty set out above.

NOTES:

1. One (1) cycle = one (1) open and one (1) close action of the door or gate.
2. This warranty is to be read in conjunction with the owner's copy of the installation instruction manual.

AUTOMATIC TECHNOLOGY AUSTRALIA PTY LTD

ABN 11 007 125 368

17-19 Advantage Rd, Highett, Victoria, Australia 3190

Tel: +61 3 9532 2788 Fax: +61 3 9532 2799

Web: www.ata-aust.com.au Email: sales@ata-aust.com.au

©October 2006 Automatic Technology Pty Ltd. All Rights Reserved. SecuraCode® and SecuraLift® are registered trademarks of Automatic Technology. In an ongoing commitment to product quality ATA reserve the right to change specifications without notice. E&OE. Printed For Export. P/N: 13228





automatic
TECHNOLOGY

smart | simple | secure

an alesco company

Automatic Technology Pty Ltd

ABN 11 007 125 368

6-8 Fiveways Boulevard
Keysborough, Victoria 3173
P 1300 133 944

E sales@ata-aust.com.au
www.ata-aust.com.au