



Auto-Lock Kit

Suits B&D Panelift, Panelift Gen II, Panelift ICON, Panelmasta, Firmapanel, P7, Design-A-Door, Enviropanel, Stormshield, Tongue and Groove. Smoothpanel and Toughpanel.

For other brand of doors, please consult your B&D approved distributor.

standard installation

GARAGE DOOR LOCK - ORDER NO. 86980		
ITEM	DESCRIPTION	QTY
1	GARAGE DOOR LOCK	1
2	COUNTERSUNK HEAD SCREW ZN M6 X 14	2
3	WIRELESS BASESTATION MODULE	1



CAUTION: Ensure bolt on Auto-lock is free to move at all times.

limited sideroom installations

DOOR BRACKET KITS		
ITEM	STRIKER BRACKET FOR DOOR:	KIT
4	PANELIFT, PANELIFT GEN II, PANELIFT ICON, PANELMASTA, FIRMAPANEL, P7, DESIGN-A-DOOR, ENVIROPANEL, SMOOTHPANEL & TOUGHPANEL	MC0071
5	STORMSHIELD	MC0070
6	TONGUE AND GROOVE	MC0072
FASTENER PACK		
ITEM	DESCRIPTION	QTY
7	FLANGE HEAD TEK SCREWS 20 X 25 CL4	4
8	MUSHROOM HEAD BOLTS 1/4" - 20 X 1/2"	3
9	FLANGE NUT 1/4"	3



WARNING! This lock has been designed to work with B&D sectional overhead garage doors.

If you fit this lock to other branded garage door, we cannot guarantee the performance of the lock and any performance warranties will not apply. This is subject to any Statutory Guarantees that may apply. Please refer to our warranty terms and conditions set out in the Openers Manual.



This device will slide a bolt into the guide track automatically when the door is closed. Not suitable for garages that have only one exit.

For emergency unlock press the lock / un lock button on the Auto-Lock. This will disengage the lock from the guide track and allow you to disengage the opener and open the door. The lock will automatically re-engage after the next complete cycle.



It is our strong recommendation that your opener be fitted with **SAFETY BEAMS**.

Safety Beams detect any obstructions in the door/gate's path and override automatic operation if one presents. These must be installed as in accordance with AS/NZS 60335-2-95:2012.

important safety instructions



WARNING!

- DO NOT attempt to disassemble, repair or modify the product. This will invalidate the warranty.
- Do NOT allow children to play with the Auto-Lock.
- Not suitable for garages that have only one exit.
- DO NOT cover, paint or lubricate the product.



CAUTION:

Burns

- DO NOT handle damaged or leaking batteries
- The Auto-Lock Kit contains sealed lead-acid batteries that must be disposed of properly at the end of their useful life.



prior to installation

preparation - setting the door limits

Ensure the door limits have been set on the opener, prior to installing the Auto-lock. Refer to the opener manual for instructions.

preparation of lock - pull tab

- Prior to installation of the Auto-lock, pull to remove the battery isolation tab.
- Once removed the battery will engage and the lock is operational.
- Test the bolt movement by manually pressing the emergency lock / unlock button.

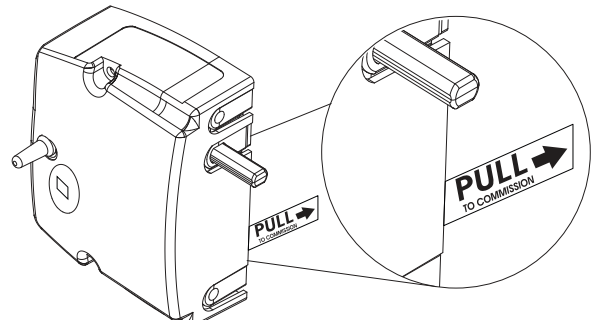

standard installation

preparation - no brackets, mounting on track

- Close the door.
- Using a marker pen, mark the position of the top of the second door wheel from the floor on the track.
- Open the door and transfer this mark to the inside of the track.
- Remove the drilling template label.
- Place the Datum line on the template on top of the line marked inside the track. Check the large hole is 10mm above the wheel.
- Drill holes in the track using 6mm and 12mm step drill bits.
- Fix the lock (1) using two M6 x 14 countersunk head screws (2).
- Close the door and check the position of the lock to the wheel. It should easily clear the wheel with 10mm clearance.
- Test the bolt runs through the track by manually pressing the emergency lock, unlock button. Make sure the bolt is not rubbing or touching any part of the track.

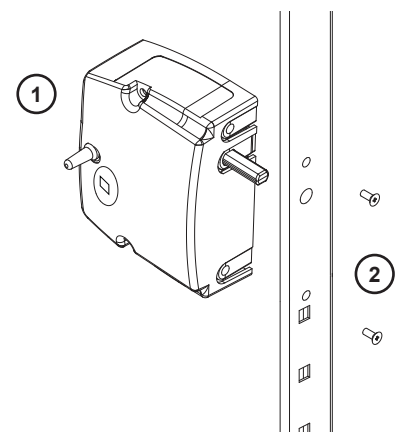

PROCEED TO CONNECTING WIRELESS BASE STATION TO THE OPENER.

limited sideroom installation

preparation - mounting on door stile

- Fit the mounting plate to the garage door lock using two M6 x 12 cross recessed screws.
- Close the door to determine mounting position of the lock on the bottom door panel and mark both on door and track.
- Open door and affix the striker bracket (4) to the track with 3 x bolts (8) and nuts (9).
- Close the door and align the lock and mounting plate (1) on the bottom panel door stile so that the lock bolt engages fully into the striker bracket (4) (allow for sideways movement of the door) and fix using 4 x flange head tek screws (7).
- Open and close the door.
- Operate the lock manually by pressing the emergency unlock / lock button making sure the lock bolt fully engages in the striker bracket without catching, adjust accordingly.
- Check that all screws (7) and striker nuts (9) are tight.

PROCEED TO CONNECTING WIRELESS BASE STATION TO THE OPENER.

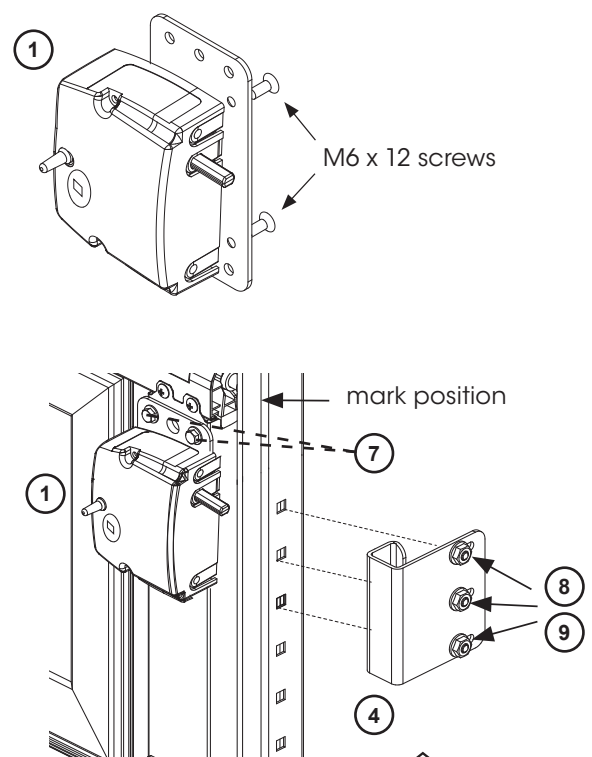

StormShield and Tongue & Groove installation preparation - mounting on door stile

- Fit the mounting bracket (5) or (6) to the lock mechanism (1) using 2 x countersunk head screws M6 x 14 (2).
- Close the door to determine mounting position between the reinforcing braces on the bottom door panel and mark. Mount the bracket and lock as marked with the 4 flange head tek screws 20 x 25 CL4 (7), however do not fully tighten as further final adjustment may be required.
- With the door in the closed position align the striker bracket with the lock allowing for vertical and horizontal movement of the door.
- Drill 3 x 1/4 holes as marked in the tracklock and fix with 3 x bolts (8) and nuts (9).
- Open and close the door, operate the lock manually make sure the lock bolt fully engages in the strike bracket without catching and adjust as required before ensuring all four tek screws and the three strike nuts and bolts are tight.

PROCEED TO CONNECTING WIRELESS BASE STATION TO THE OPENER.

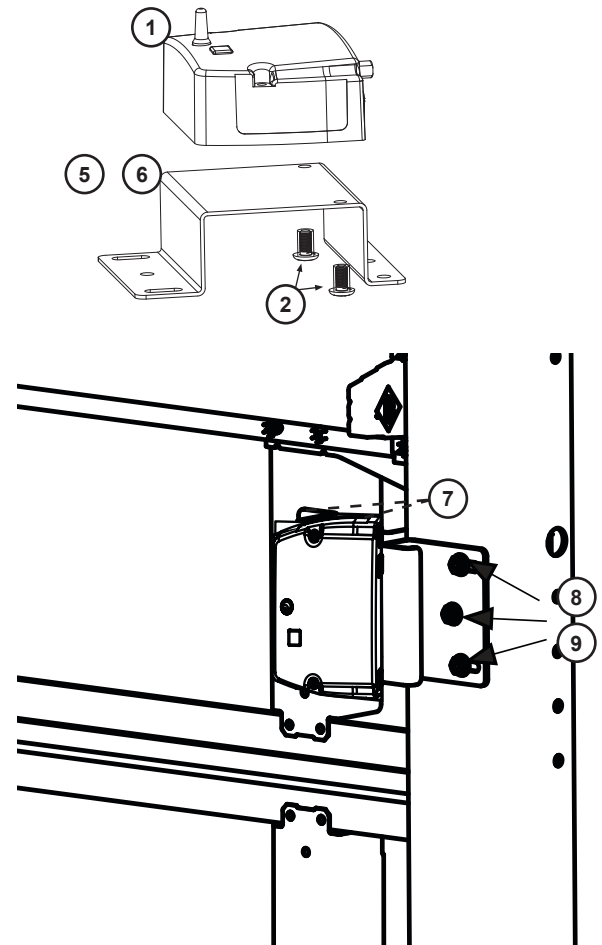

connect wireless basestation to opener preparation of opener

- Disconnect the power supply to the opener.
- Remove the left hand side pocket from the opener.
- Reach inside the opener and pull out the 5 pin harness and connect to the wireless basestation module.
- Place the module (3) into the pocket and refit the pocket cover.

test the opener

- Ensure the lock drive unit is connected to the lock mechanism.
- Reconnect power to the opener and test operation.
- Upon completion of a full cycle the lock bolt will engage into the track.

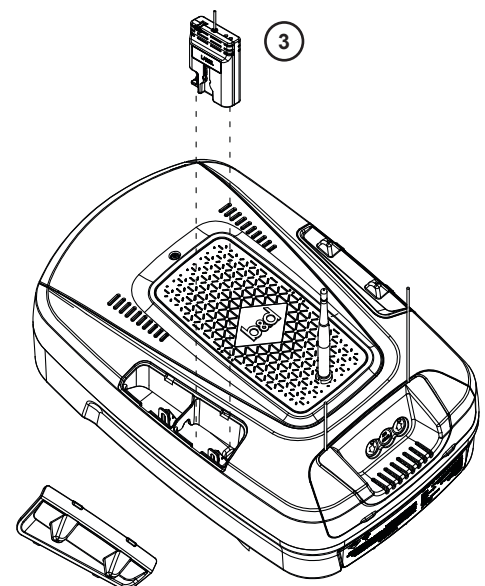

operation

how to operate

Press the emergency lock/unlock button on the front of the Auto-Lock to disengage the lock from the guide track and allow you to disengage the opener and open the door.



WARNING! The emergency lock/unlock button on this product is not to be used as a primary means of locking the door under normal circumstances.

The emergency lock/unlock button is to be used only in case of power outage or emergency.

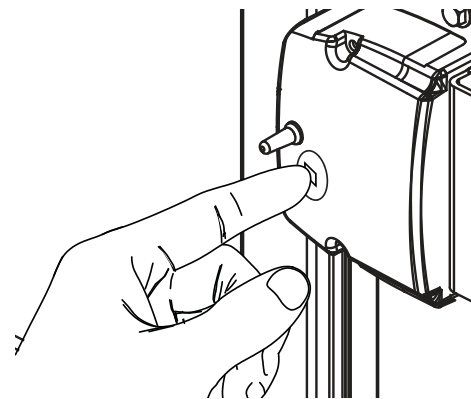

battery change

low battery warning

- Replace Lock Batteries (2 x C-LR 14) Immediately when opener light flashes three (3) times.
- Remove cover by unscrewing the two (2) screws on the main cover.
- Replace batteries and refit cover and secure with two (2) screws.

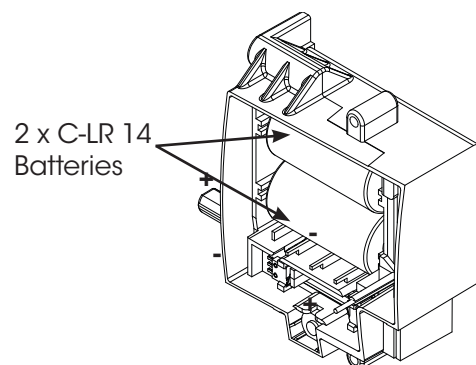

troubleshooting

problem	cause	remedy
door not moving	communication failure	switch off power to opener, the switch back on after 30 secs (If a battery backup is installed press & hold STOP/SET button on the opener until power ceases). Press the lock/ unlock button on the lock to test operation.
lock is not unlocking and preventing doors movement	lock jammed	Press the lock/ unlock button on the lock to test operation.
	door wheel is pushing on the lock barrel.	check the lock barrel is not catching on the track.

warranty

Refer to the Opener Instruction manual for warranty details.

For all other components of the product (Auto-Lock Kit) the warranty is valid for a period of one year.

b&d group office locations

Head Office	6-8 Fiveways Blvd, Keysborough 3173	Phone (03) 9791 0200
New South Wales	34 Marigold St, Revesby 2212	Phone (02) 9722 5555
Queensland	17 Oasis Court, Clontarf 4019	Phone (07) 3883 0200
Victoria	147-153 Canterbury Rd, Kilsyth 3137	Phone (03) 9237 7766
South Australia	23 Frederick Rd, Royal Park 5014	Phone (08) 8440 4747
Western Australia	96 Mulgul Rd, Malaga 6090	Phone (08) 9247 8777
International/Export	34 Marigold St, Revesby 2212	Phone +61 (0)2 9722 5555

your representative is

Prefixed trademarks are the property of B&D Australia Pty Ltd. B&D Doors & Openers is a division of B&D Australia Pty Ltd. ABN 25 010 473 971. © 2016 B&D Australia Pty Ltd.

www.bnd.com.au