



# TRI-TRAN™ WIRELESS KEYPAD INSTALLATION INSTRUCTIONS

PART NO 062269

Tri-Tran™ Wireless Digital Keypad is designed for use with automatic garage door and gate openers. The Tri-Tran™ format provides unparalleled security with more than 99 million different codes. To operate, the user enters their unique pin code on the Wireless Keypad (4 to 8 digits long) followed by the hash (#) key. The user then presses one of the eight available channels.

Familiarise yourself with the following instructions prior to commencing set up. Store this information including your new pin code in a safe place for future reference.

## Initial Set Up

The Wireless Keypad is supplied with a factory preset code (1111) which must be changed to a new pin code before the Wireless Keypad will operate. The pin code can be any 4-8 digits number except 1111.

## Storing your pin code

Note: There is a timeout of approximately 5 seconds after the last button is pressed.

- Enter 1111 followed by the hash (#) key.
- Press and hold the hash (#) key again. The keypad will beep for approximately 5 seconds. Once the beeping stops, release the hash (#) key. Enter the new pin code followed by the hash (#) key. Re-enter the new pin code followed by the hash (#) key to confirm. A short string of beeps will be produced to confirm the acceptance of the new pin code.
- Test operation using the new code. Enter the new code followed by the hash (#) key. Press and hold any button from 1-8 and you should hear a continuous string of beeps.

NOTE: If you lose or forget a code, you will need to return the Wireless Keypad to B&D Doors for reprogramming. A charge will apply for this service.

## Coding The Wireless Keypad Into The Opener

- Press the CODE SET button and release. The CODE SET LED will illuminate to indicate that the opener is in Code Learn mode. If a valid code is not stored within 15 seconds, the opener will exit Code Learn (Fig. 02).
- Enter your pin code on the Wireless Keypad followed by the hash (#) key. Then press one of the eight (channel) buttons you wish to use to operate the door or gate etc. The CODE SET LED will flash.
- Pause for a second and press the same button again on the Wireless Keypad. The CODE SET LED will illuminate for one second then go out.
- Test the operation of the Wireless Keypad by entering your pin code followed by the hash (#) key and the stored channel button (1-8). The door should start to move.

## Coding The Wireless Keypad Into The Tri-Tran™ receiver

- Press and hold SW1/SW2 on the Tri-Tran™ receiver board (Fig. 03).
- Enter your pin code on the Wireless Keypad followed by the hash (#) key. Then press one of the eight (channel) buttons you wish to use to operate the door or gate etc.
- Pause for a second and press the same button again on the Wireless Keypad.
- Release the SW button. The Wireless Keypad code should now be stored into the receiver's memory.
- Test the operation of the Wireless Keypad by entering your pin code followed by the hash (#) key and the stored channel button (1-8).

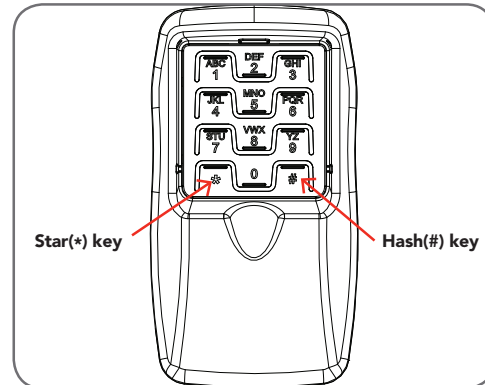

Fig.01

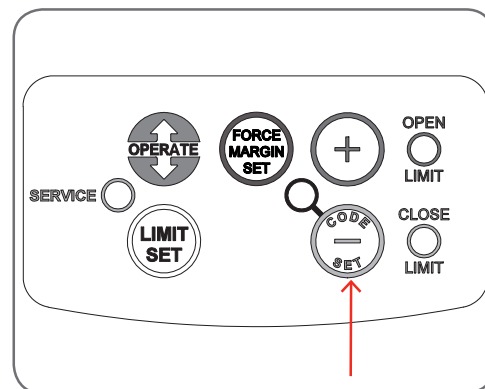

Fig.02

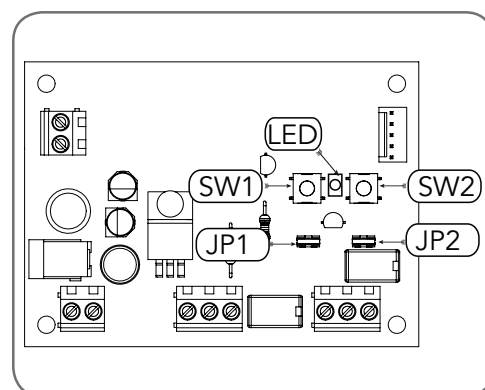
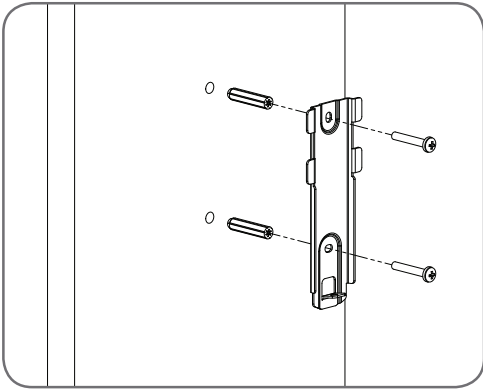

Fig.03



# Tri-Tran™ Wireless Keypad Installation Instructions

Fig.04



## Attaching The Wireless Keypad To The Wall

- Choose a convenient wall location where the door is visible, but out of reach of children at a height of at least 1.5 metres from the floor.
- Use the mounting bracket as a template. Mark and drill two 6mm holes and affix the mounting bracket with two wall plugs and screws (supplied) as shown in **Fig. 04**.
- Slide the Wireless Keypad on to the mounting bracket and secure it with a screw as shown in **Fig. 05**.

## Changing the Pin Code

Note: There is a timeout of approximately 5 seconds after the last button is pressed.

- Enter your current pin code followed by the hash (#) key.
- Press and hold the hash (#) key again. The keypad will beep for approximately 5 seconds. Once the beeping stops, release the hash (#) key. Enter the new pin code followed by the hash (#) key. Re-enter the new pin code followed by the hash (#) key to confirm. A short string of beeps will be produced to confirm the acceptance of the new pin code.
- Test operation of the Wireless Keypad by entering your pin code followed by the hash (#) key and the stored channel button (1-8). The door or gate should start to move.

## Wrong Pin Code

If a wrong pin code is entered, a specific sound is heard after pressing the hash (#) key. The star (\*) key must be pressed to start re-entering the pin code. On the fourth consecutive wrong pin code entry, an alarm (light blinks and sound beeps) is triggered for 10 seconds. Every next wrong pin code entry will trigger the alarm. The time out for the wrong pin code is one minute.

## Back Light

The Wireless Keypad has built-in keypad lighting for use at night or in dark areas. The keys are backlit with a pleasing green glow. The user can light the keypad by pressing the star (\*) or the hash (#) keys before entering the pin code. The light will turn off after 5 seconds if none of the buttons are pressed. This saves the battery power.

## Battery Monitor

The Wireless Keypad has a built-in battery monitor. If the battery power is low, the first depress of any key will produce a distinctive warning. If the battery voltage drops further, the Wireless Keypad will stop transmitting and will produce a continuous long beep.

## Changing Batteries

- Remove the back cover of the Wireless Keypad by removing the six screws as shown in **Fig. 06**.
- Remove the three (3) batteries and dispose of properly.
- Install fresh AAA size batteries.
- Replace the back cover.
- Install the six cover screws.

Fig.05

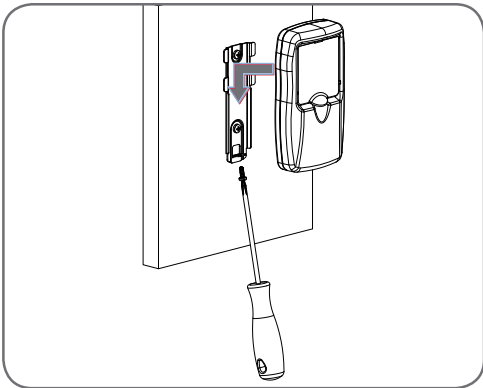
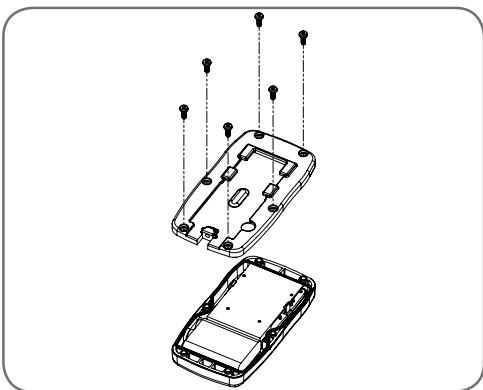

Fig.06



## B&D Doors Office Locations:

Brisbane: 17 Oasis Court, Clontarf 4019.

Phone: (07) 3883 0200

Melbourne:

147-153 Caterbury Rd, Kilsyth 3137. Phone: (03) 9237 7766

Sydney: 34 Marigold St, Revesby 2212.

Phone: (02) 9722 5555

Adelaide:

23 Frederick Rd, Royal Park 5014. Phone: (08) 8440 4747

Newcastle: Unit 1/108 Mitchell Rd, Cardiff NSW 2285

Phone: (02) 4956 8533

Perth:

96 Mulgul Rd, Malaga 6090. Phone: (08) 9247 8777



Prefixed trademarks are the property of B&D Australia Pty Ltd  
B&D Doors & Openers is a division of B&D Australia Pty Ltd, an Alesco company  
ABN 25 010 473 971  
Copyright 2008 B&D Australia Pty Ltd.

An  Alesco Company

Website: [www.bnd.com.au](http://www.bnd.com.au)

YOUR REPRESENTATIVE IS