

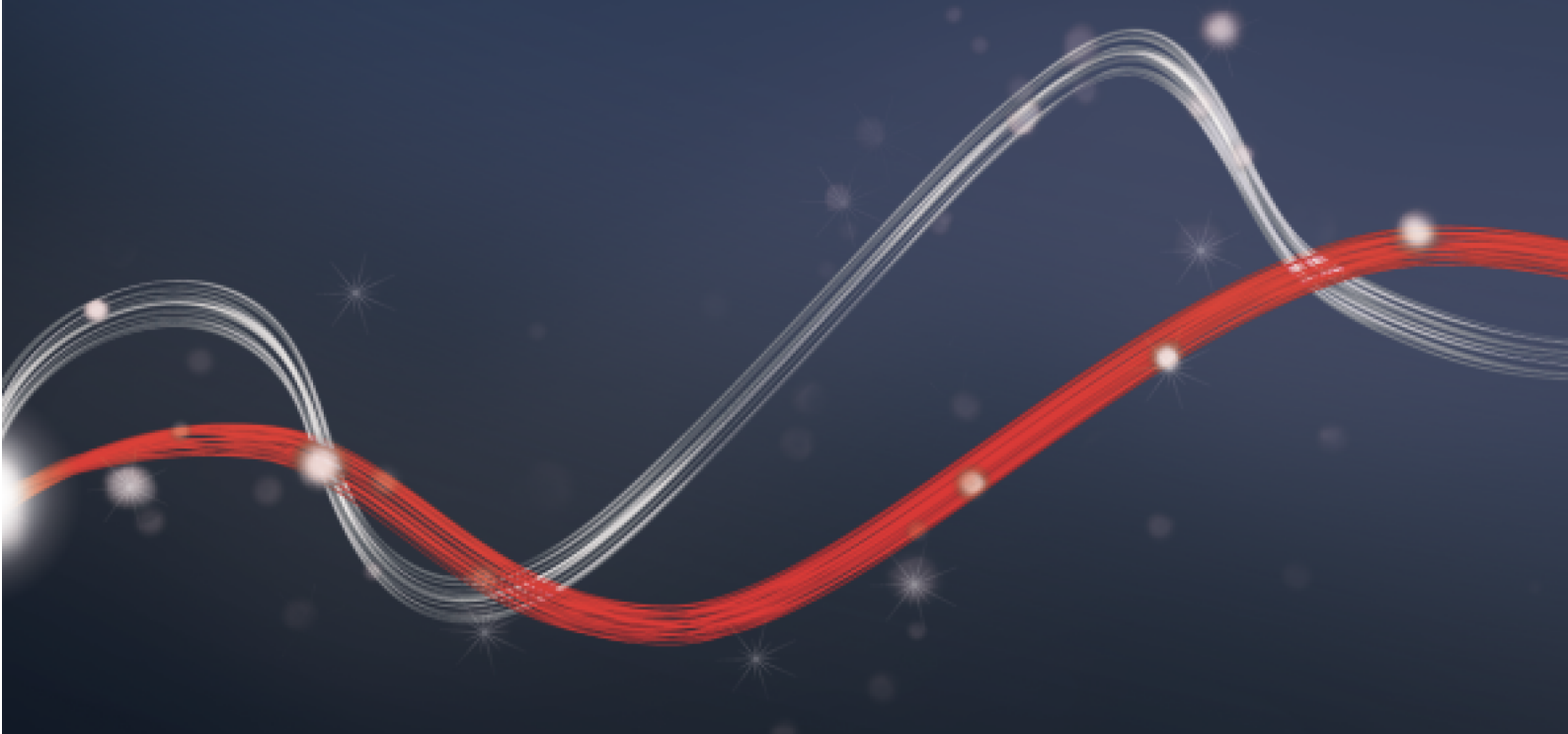

Be ahead



ECOSOL





Solar power supply system

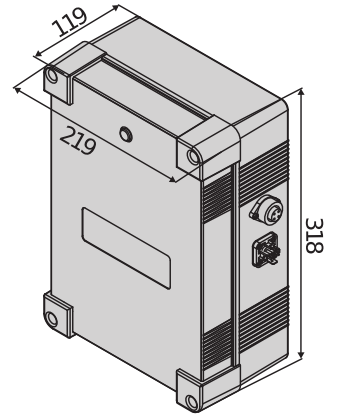
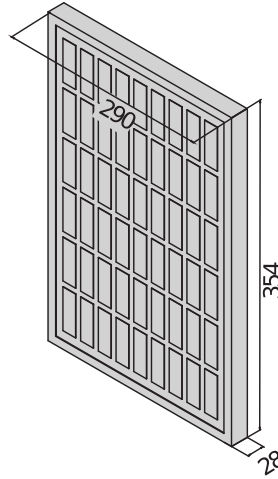

Ecocol is a complete solar powered system for low-voltage installations. Ideal for doors and gates that are not easily reached from the power mains, it adapts to any context thanks to compatibility with all 24V systems, both old and new.

Relevant features



The system components are interconnected with sealed, quick-fit connectors to ensure maximum simplicity in daily use.



The control panels have a useful handle to make them easy to carry when they have to be connected to the electricity mains to recharge the batteries.



"Vandal-proof" versions of screws and fasteners can be supplied to guarantee maximum security and safety in all situations.

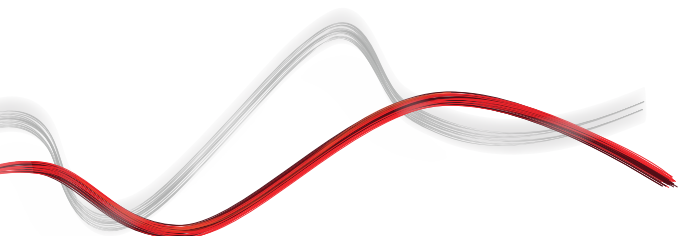



Solar power supply system

ECOSOL

Code	Name	Description
D113731	ECOSOL BOX	Control and management unit for solar power supply of systems with supply voltage of 24 V. Batteries included.
D113750	ECOSOL BOX NO BATTERY	Control and management unit for supplying solar power to systems with supply voltage of 24 V. Batteries not included.
N999471	ECOSOL PANEL	Solar-powered system compatible with BFT systems only

	ECOSOL BOX	ECOSOL BOX NO BATTERY	ECOSOL PANEL
Nominal voltage	24 V	24 V	24 V
Maximum current	10 A	10 A	no A
Peak power	no Wp	no Wp	10 Wp
Battery nominal capacity	7,20 Ah	7,20 Ah	no Ah
Battery type	12 A	12 A	no A
Maximum panel power	35 Wp	35 Wp	35 Wp
Consumption in standby	0,15 W	0,15 W	no W
Protection rating	IP55	IP55	IP65
Environmental conditions	-20 ÷ 50 °C	-20 ÷ 50 °C	-20 ÷ 50 °C

RECOMMENDED ACCESSORIES

	D113732 - ECOSOL DOUBLE Expansion board with batteries Included		N999473 - ECOSOL POST BR Set of stainless steel screws and brackets for installing the ECOSOL PANEL on a post of diameter 48-100mm
	N999475 - ECOSOL SECURITY Anti-tamper stainless steel screws and fasteners for ECOSOL PANEL and ECOSOL POST BR		N999476 - ECOSOL CABLE 20 m extension for ECOSOL CHARGER
	N999477 - ECOSOL CHARGER Battery chargers for ECOSOL BOX and ECOSOL DOUBLE		

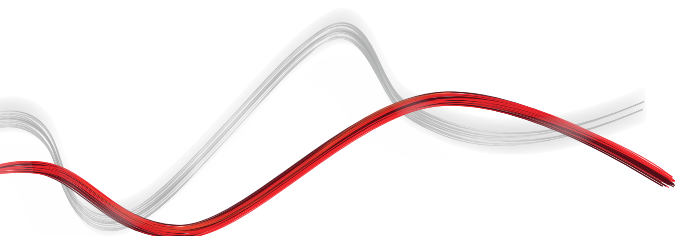



Solar power supply system

What is U-Link?

The technology that gives you more power

U-Link, Universal Link, is an exclusive BFT platform that can be used to create high-tech ecosystems. In Home Access Automation, it can be used to communicate with all home access automation devices of any brand. This saves you time and allows you to control everything easily and without any worries.

It is intuitive

Easy to install and to use

It is scalable

You can add as many devices as you want

It is flexible

It allows you to create groups of interconnected products

It is practical

Works with or without an internet connection

It is functional

Its settings can be controlled remotely using dedicated applications



Solar power supply system

Everything on one screen: find out more about this amazing technology

A world-exclusive platform that **can be used to create high-tech ecosystems** offering a vast range of solutions for many different sectors.

This proprietary platform which is a key feature of BFT products, thanks to the B-EBA cards and the Clonix U-Link receiver, is suitable for any protocol or product for access automation (including BFT products non-BFT ones and older versions) and it can be used in a variety of different sectors. This means any device becomes a smart device which can be interconnected with other systems, using a language that is becoming universal.



U-Control HOME

U-Control HOME is the application that allows you to open the gate to your home and to remotely control BFT automations using your own smartphone. The iOS version can be used to automatically open the automation when you are close to it.



U-Base 2

A software package for installation, performing maintenance and identifying any faults in the U-Link compatible operators, easily and conveniently.

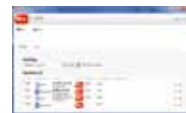

U-SDK

U-SDK is the application which allows BFT automations to be made compatible and easily integrated with a BMS network.



Clonix U-Link

Connect non-native U-Link and non-BFT products to U-Link systems.

Is it possible to connect non-native U-Link BFT operators or other brands of products to U-Link? Yes, thanks to the Clonix receivers. Accessories which accept no limits.



B-EBA

A direct link to your operators.

The B-EBA expansion cards make it possible to connect external devices such as PCs, smartphones and tablets to a BFT operator and a Clonix receiver or to connect multiple BFT products in a U-Link network. These accessories integrate with U-Link technology and with Bluetooth, Wifi, Z-Wave and TCP/IP protocols as well as with the RS485 serial interface. A device that demonstrates exactly what BFT means by interconnectivity.

