

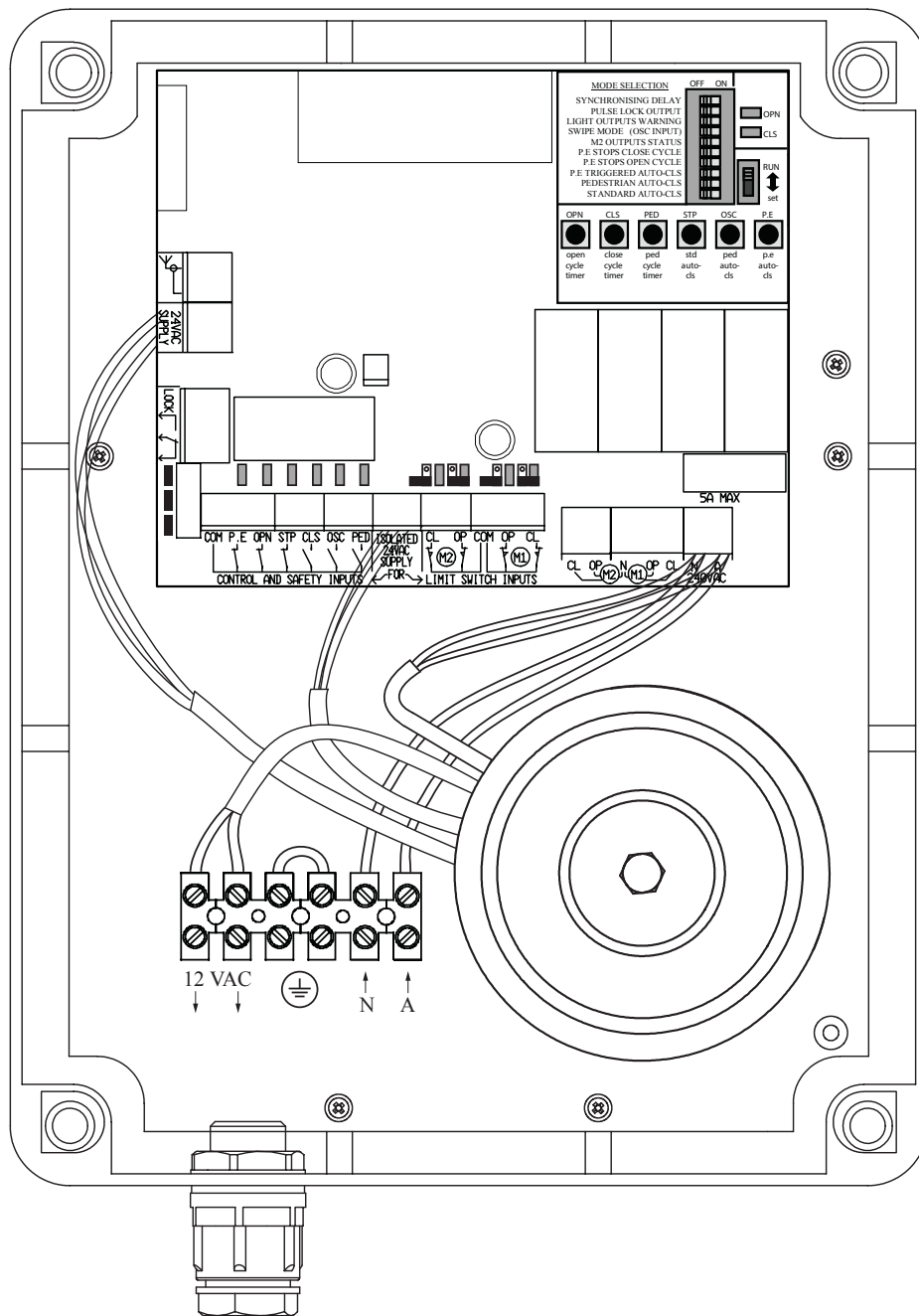

CB-6 Control Box

For automating single or three phase motors



automatic
TECHNOLOGY

CB-6 Control Box

For automating single or three phase motors

1. Important Safety Instructions	3
2. Installation Requirements	4
2.1 Kit Contents	4
2.2 Power Requirements	4
3. Operating Controls	5
4. Controlling Motors	6
4.1 Controlling Single Phase Motors	6
4.2 Controlling Three Phase Motors	6
5. Wiring Input Terminals	8
5.1 Control and Safety Input Terminals	8
5.2 Interlocking Motor Drive and Safety Inputs	8
6. Wiring Terminals	9
7. Wiring Lights	10
7.1 Wiring Light Relay Module to Courtesy Warning Light.	10
7.2 Wiring M2 Output Lights to show Gate status	10
8. Wiring Locks	11
8.1 Lock Release Output for Solenoid Locks	11
8.2 Lock Release Output for Electromagnetic Locks	11
9. Mode Selection	12
10. PG-3 Programmer Compatible	14
10.1 Connect to Device	14
10.2 Device Main Screen	14
10.3 Firmware Upgrade	14
11. PG-3 Settings	15
11.1 Settings	15
11.2 Programming CB-6 Board via settings	15
12. Cycle and Autoclose Times	16
12.1 Setting Open, Close and Pedestrian Access Cycle Times	16
12.2 Setting P.E Triggered Autoclose Delay Time	16
12.3 Setting Pedestrian Access Autoclose Delay Time	16
12.4 Setting Standard Autoclose Delay Time	16
13. Autoclose Modes	17
13.1 Autoclose after reaching the Open Position	17
13.2 Autoclose after being opened for Pedestrian Access	17
13.3 Autoclose after cycle if PE has been triggered	17
13.4 Mixing Autoclose modes	17
14. Specifications	18
15. Troubleshooting	19
16. Appendix	20
A - Special Adjustments	20
B - Operating Parameters	21
C - Reloading Memory with Factory Default Times	21
D - Specialised Operating Modes	22
E - Powering Control Board (no control box)	23
17. Warranty and Exclusion of Liability	24





1. Important Safety Instructions

The safety alert symbols below indicate a personal safety or property damage instruction exists. **READ THESE INSTRUCTIONS CAREFULLY.** This CB-6 Control Board is designed and tested to offer safe service provided it is installed and operated in strict accordance with the following safety rules. Failure to comply with the following instructions may result in death, serious personal injury or property damage.



WARNING!

- The gate/door may operate unexpectedly, therefore do not allow anything to stay in the path of the gate/door.
- Do not disengage the gate/door opener to manual operation with children/persons or any objects including motor vehicles within the gateway/doorway.
- Remove or disengage all gate/door locks and mechanisms prior to installation of the opener.
- Make sure the gate/door is fully open before driving into or out of the driveway.
- When using auto close mode, a **Photo Electric beam** must be fitted correctly and tested for operation at regular intervals. **Extreme caution** is recommended when using auto close mode. **All safety rules** must be followed.



ELECTROCUTION!

- Do not immerse in or spray the Control box with water .
- **Disconnect the power cord** from mains power before making any repairs or removing covers. Only **experienced** service personnel should remove covers from the gate opener.
- If the power supply cord is damaged, it **must** be replaced by an Automatic Technology service agent or suitably qualified person.
- Connect the control box to a properly **earthed** general purpose 240V mains power outlet installed by a qualified electrical contractor.



CAUTION:

Entrapment from operating gate

- **DO NOT** operate the gate opener unless the gate is in full view and free from objects such as cars and children/people. Make sure that the gate has finished moving before entering or leaving the driveway.
- Do not allow children to play with gate controls or transmitters.
- Regularly check to make sure that the **control box is operating properly**. Failure to follow these instructions could result in **serious personal injury** and/or property damage.
- If using a key switch, keypad or any device that can operate the gate/door opener, make sure it is in a location where the gateway is visible, but out of the reach of children at a height of at least 1.5m.
- For **ADDITIONAL SAFETY** protection we **STRONGLY** recommend the fitting of a Photo Electric (Safety) Beam. In most countries Safety Beams are mandatory on all gates fitted with automatic openers.

Installation

- Ensure the door/gate(s) is in good working order . Faulty gate(s)/door must be repaired by a qualified technician prior to installation.
- Frequently examine the installation and mountings for signs of wear, damage or imbalance. DO NOT use if repair or adjustment is needed since a fault in the installation or an incorrectly balanced gate/door may cause injury.

Security

Entanglement in or laceration from moving gate

- Make sure that the gate/door is fully closed before leaving the driveway.
- Keep hands and loose clothing clear of gate at all times
- Keep clear of gate/door during operation as severe lacerations can occur on sharp edges of gate/door.

Automatic Technology Australia Pty Ltd to the extent that such may be lawfully excluded hereby expressly disclaims all conditions or warranties, statutory or otherwise which may be implied by laws as conditions or warranties of purchase of an Automatic Technology Australia Pty Ltd Garage Door Opener. Automatic Technology Australia Pty Ltd hereby further expressly excludes all or any liability for any injury, damage, cost, expense or claim whatsoever suffered by any person as a result whether directly or indirectly from failure to install the Automatic Technology Australia Pty Ltd Garage Door Opener in accordance with these installation instructions.

2. Installation Requirements



IMPORTANT SAFETY INSTRUCTIONS FOR INSTALLATION

Warning: Incorrect installation can lead to severe injury.

Follow ALL installation instructions.

ONLY qualified electrical contractors are to connect the control box to a properly earthed general purpose 240V mains power outlet.

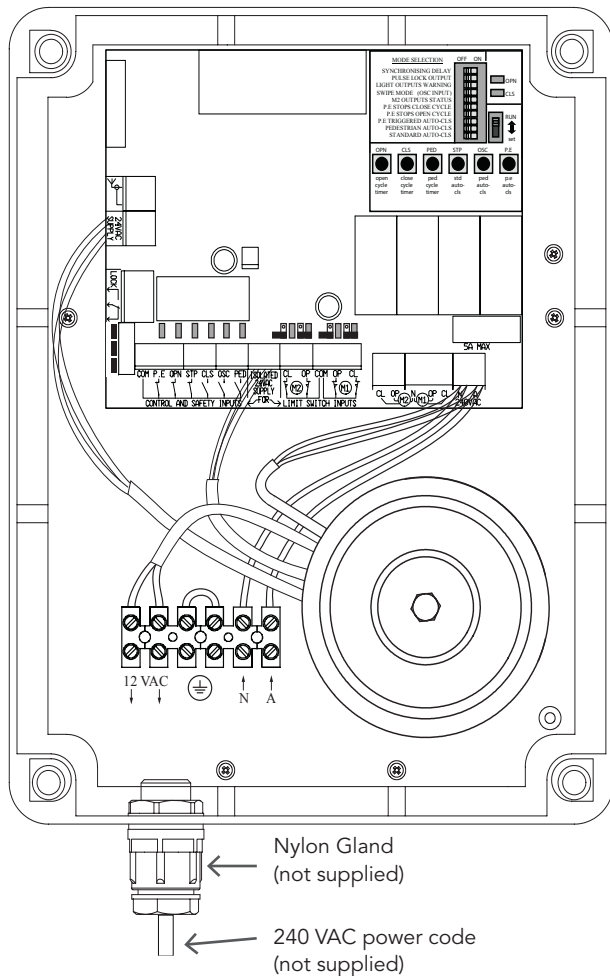

Fig 2.1: CB-6 CONTROL BOX

2.1 Kit Contents

ITEM	DESCRIPTION	QTY	ORDER CODE
------	-------------	-----	------------

CB-6 CONTROL BOX ORDER NO. 60605

1	CONTROL BOX ASSY CB-6 V1.07	1	60605
2	MOUNTING LUGS FOR GEWIS BOX	4	64820
3	SCREW "P" M3.5 X 13	4	64826

CB-6 CONTROL BOARD ORDER NO. 60720

4	LOGIC CONTROL BOARD CB-6 V1.07	1	60720
---	--------------------------------	---	-------

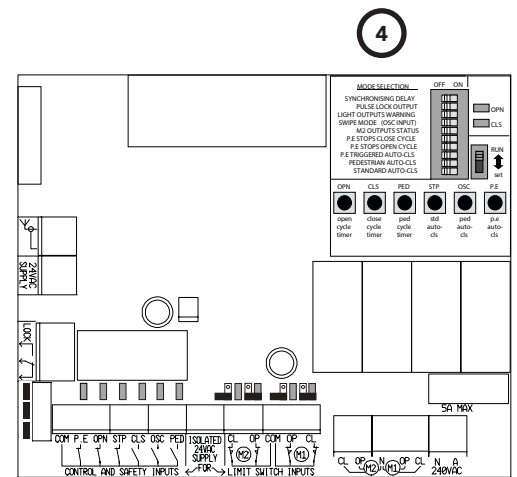
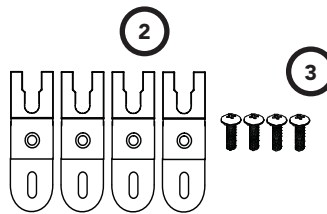

Fig 2.2: CB-6 CONTROL BOARD

2.2 Power Requirements

Drill a 16mm hole in the Control Box enclosure (recommend at the bottom) and fit a M16 nylon gland (not supplied) or similar. Feed wires from opener through nylon gland and connect to the N and A points in the terminal block



ELECTRICUTION! ONLY qualified electrical contractors are to connect the control board to a properly earthed general purpose 240V mains power outlet.

A second gland may be required for installation with coax cable Antenna's.

3. Operating Controls

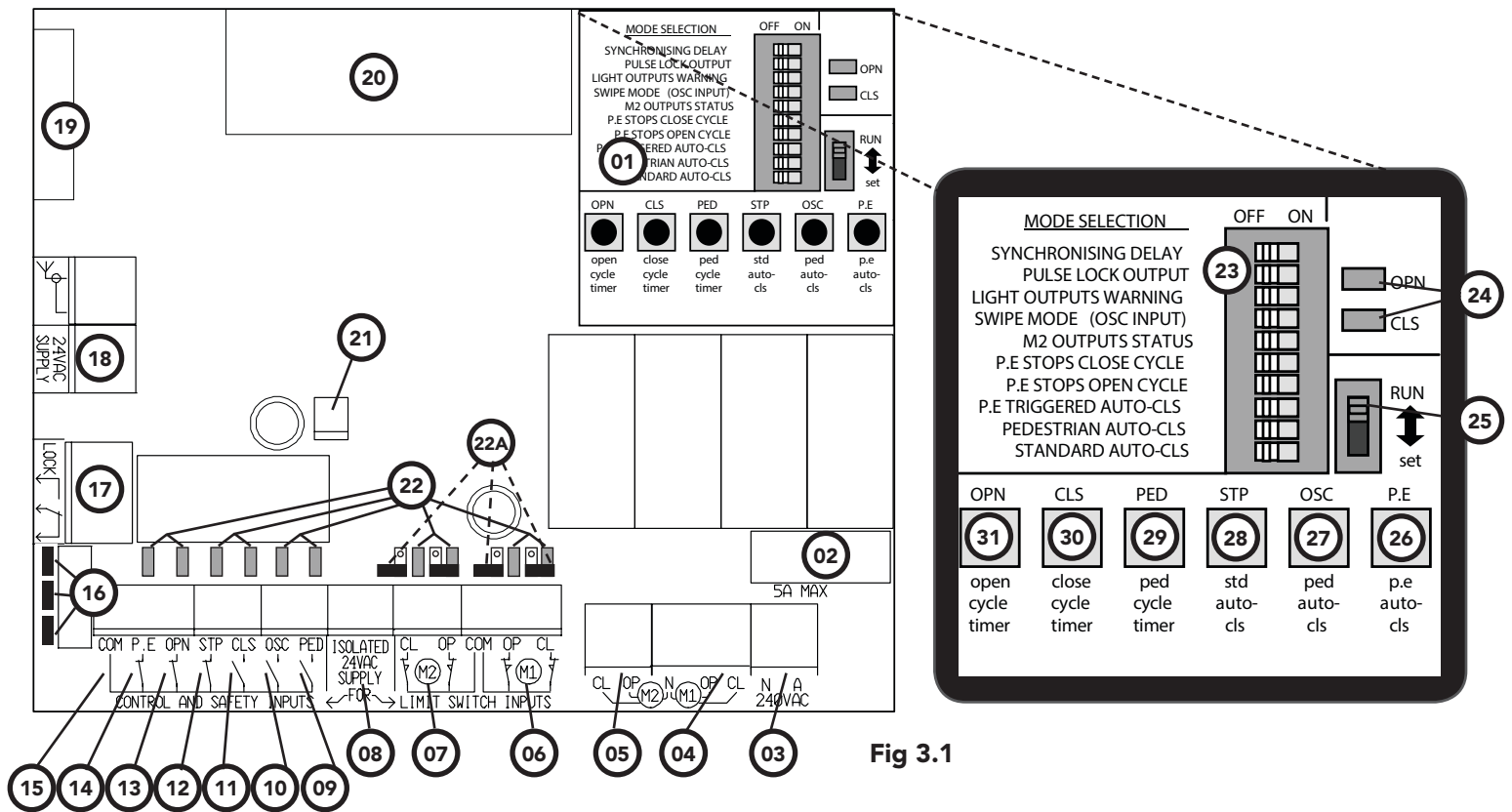

Fig 3.1

- | | | |
|--|------------------------------------|---|
| 01 Mode Selection and Adjustment | 09 Pedestrian Access Control Input | 18 Terminals for 24VAC Supply for Control Logic |
| 02 Motor Protection Fuse | 10 Open/Stop/Close Control Input | 19 Connector for Plug-in Receiver |
| 03 Mains 240VAC Input Terminals | 11 Close Control Input | 20 Adaptor Board |
| 04 Motor 1 Drive Output Terminals | 12 Stop Control Input | 21 Light Control Relay Interface Connector |
| 05 Motor 2 Drive Output Terminals | 13 Open Control Input | 22 Input Status LEDs (illuminated when input is connected to COM) |
| 06 Motor 1 Limit Switch Inputs | 14 Photoelectric Safety Beam Input | 22A Clack Shunts for Limit Switch Inputs |
| 07 Motor 2 Limit Switch Inputs | 15 Common Terminal for [9] to [14] | 23 Mode Selection Dip-Switches |
| 08 Terminals for Isolated 24VAC Supply for Limit Switch and Control Inputs | 16 Clack Shunts for OPN, STP, PE | 24 Status Indication LEDs |
| | 17 Electric Lock Control Terminals | |

25 "RUN / set" Selection Slide Switch
26 to 31 act differently depends on the position of slide 25 switch

Function when "RUN" Position is Selected

- 26 Simulates P.E Control Input
- 27 OPEN/STOP/CLOSE Input
- 28 STOP Input
- 29 Pedestrian Access Input
- 30 CLOSE Input
- 31 OPEN Input

Function when "set" Position is Selected

- 26 P.E Trigger Autoclose Timer Set
- 27 Pedestrian Autoclose Timer Set
- 28 Standard Autoclose Timer Set
- 29 Pedestrian Access Cycle Time Set
- 30 CLOSE Cycle Time Set
- 31 OPEN Cycle Timer Set

4. Controlling Motors

The CB-6 Control Board can control one to two large single or three phase motors with the addition of suitable contactors. Control inputs for open, close, stop, open/close/stop, pedestrian access, card swipe and photoelectric safety beams are provided.

4.1 Controlling Single Phase Motors

The CB-6 Control board can connect two single phase motors and associated limit switches (if used).

- If the limit switches are not used then simply place Clack Shunts (22A) over both pins.
- If only motor one is to be controlled then simply ignore the motor and limit switch connections for motor 2.
- Connect motor and limit switches as per **Fig 4.1**.

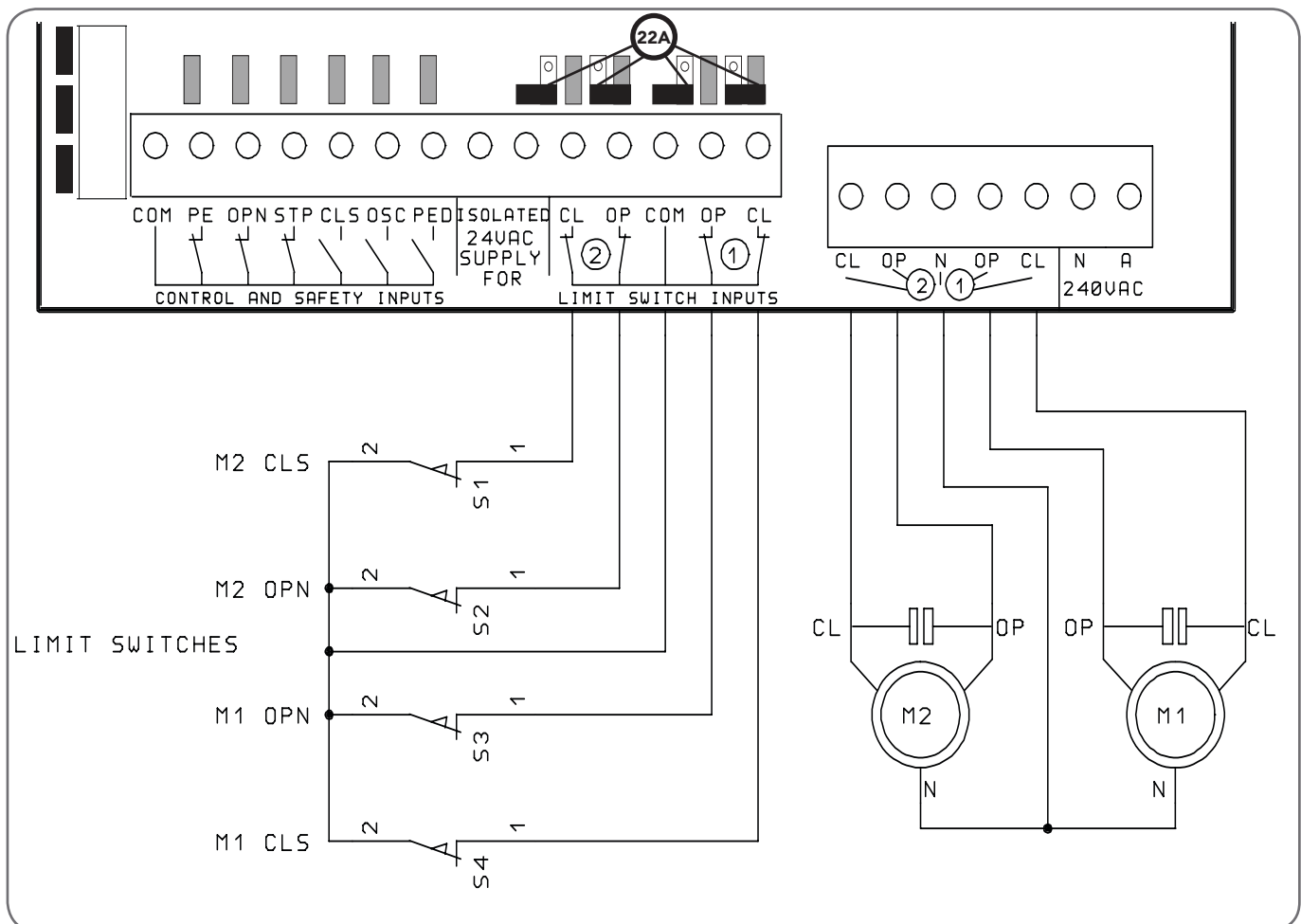

Fig 4.1



ELECTRICUTION! Make sure that the motors are properly earthed.

NOTE: The state of the limit switch inputs is indicated by the LED's (22) located behind the limit switch terminals. The LED for a particular input will light if that input terminal is connected to the COM terminal.

4. Controlling Motors

4.2 Controlling Three Phase Motors

When the CB-6 is connected to a three phase motor with limit switches, the control board's motor outputs directly drive the coils of the open and close contactors **Fig 4.2**. The other side of the contactor coils are connected to neutral via the normally closed motor limit switches (S1 and S2). This forms an interlock which turns off the contactor and prevents it from being operated when its associated limit switch is activated. This interlock action is desirable in the unlikely event of the control board malfunctioning.

NOTE: The contactors are mechanically and electrically interlocked via a set of normally closed auxiliary contacts placed in series with the COIL drive output from the control board.

- The normally open auxiliary contacts of each contactor are connected to the control board's limit switch inputs and used to indicate when the contactor has been turned off by the limit switch interlock.
- The control board's limit switch inputs interlock with the motor output relays, because the auxiliary contacts connected to the limit switch inputs are normally open the motor output relays are prevented from being operated.
- This is where the two diodes connected to COM via the lock output in PULSE mode come into play. At the start of each drive cycle the lock output connects the limit switch inputs to COM for ~ 0.3 seconds which is long enough for the control board's output to turn on and energise the contactor coil provided the limit switches are closed.
- This closes the auxiliary contact which then maintains a closed contact on the limit switch input when the lock pulse output turns off.
- This state remains until either the control board turns off the motor output or when the motor's limit switch is reached in which case the power to the contactor coil is interrupted and the auxiliary contact opens.
- The opening auxiliary contact signals to the control board that the motor's travel limit has been reached. By signalling to the control board when the motor has finished a drive cycle, all of the control functions can be utilised.
- If two motors are to be controlled simply duplicate the limit switches, contactors, etc. for motor 2.

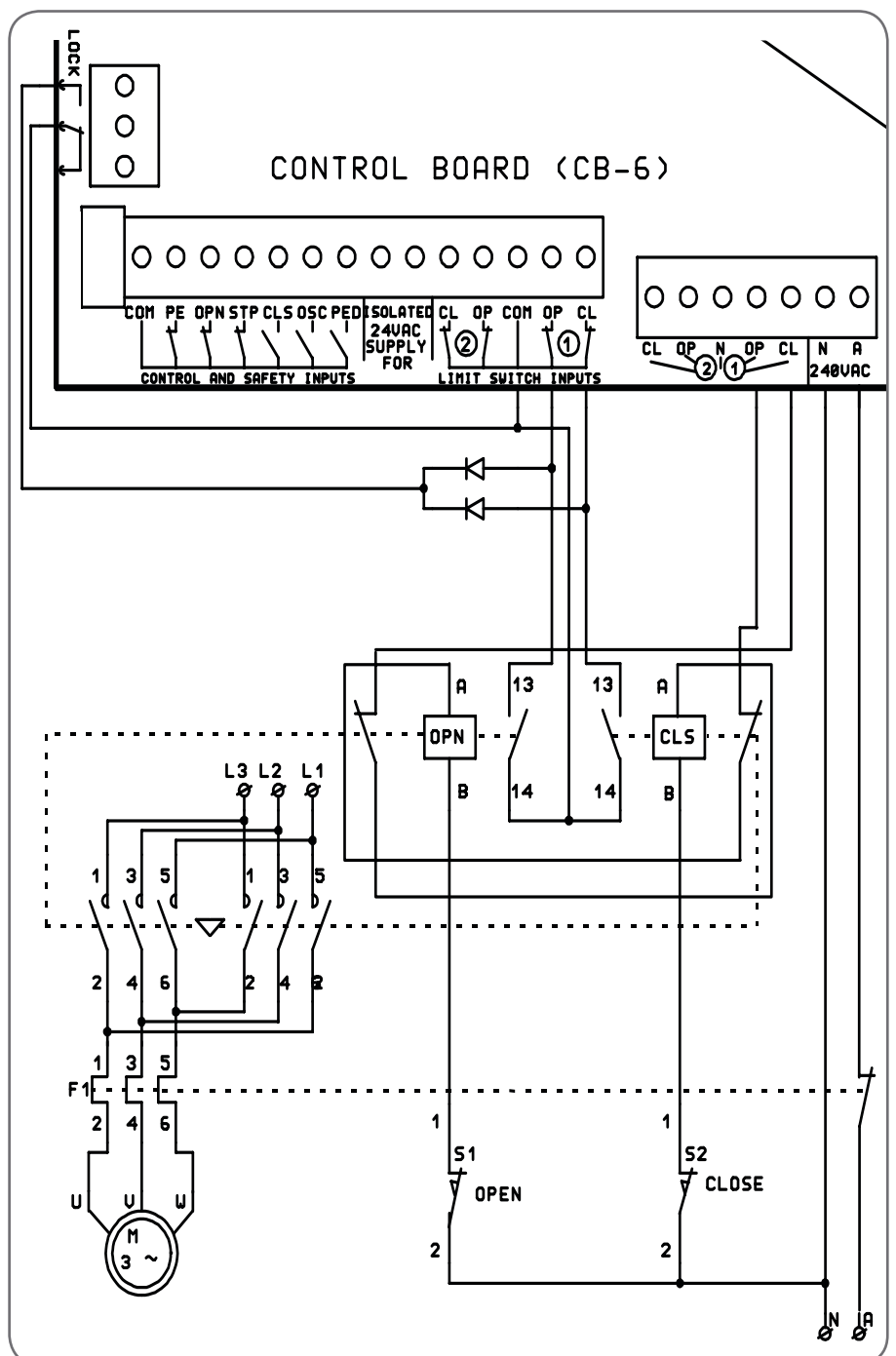

Fig 4.2



ELECTRICUTION! Make sure that the motors are properly earthed.

5. Wiring Input Terminals

5.1 Control and Safety Input Terminals

Fig 5.1 shows how to wire the control and safety input terminals to switches.

- The P.E, OPN and STP inputs require a normally closed switch contact. If not used leave the clack shunts (16) in their position.
- The CLS, OSC and PED inputs require a normally open switch contact. If not used these inputs should be left unconnected.



WARNING! At no time should a voltage or current be applied to the Inputs as this may permanently damage the control board or severely reduce its reliability. Switch wiring should be kept as short as possible and away from sources of electrical interference as this may falsely trigger the control board's inputs.

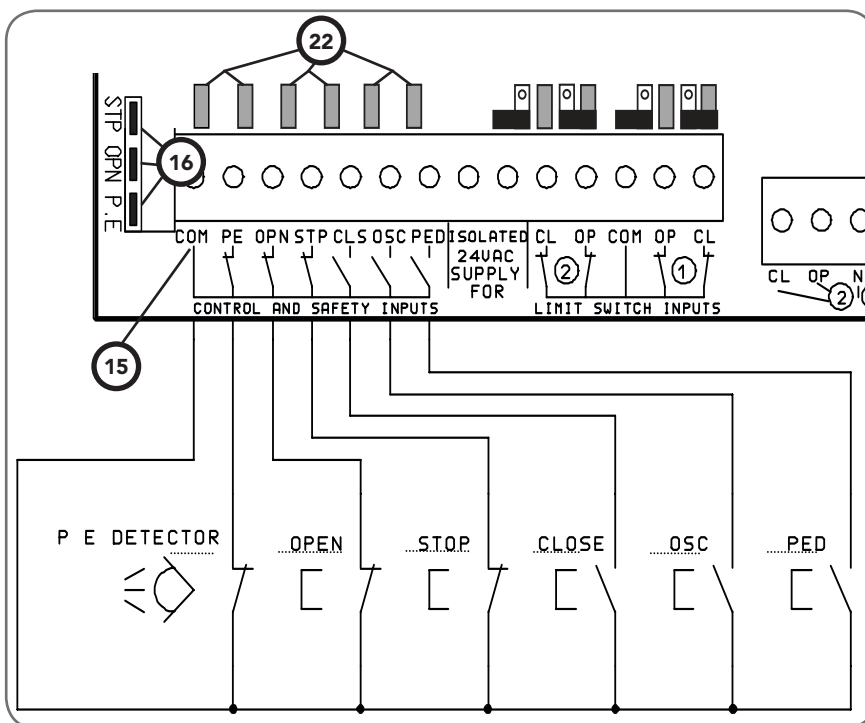

Fig 5.1

- If the switch is to be located away from the control board or the switch supplies a voltage, the isolation module IM-1 available from Automatic Technology or a similar device should be used to isolate the switch and/or the long wiring from the control board input.

NOTE: The condition of each input is indicated by the LED's (22) located behind each input terminal. The LED for a particular input terminal will light when that input is connected to the COM terminal (15).

5.2 Interlocking Motor Drive and Safety Inputs

The control board has been designed so that the fail safe interlocking action of the limit switch inputs with the motor drive outputs can be utilised to also interlock the motor drive outputs with the required safety inputs. **Fig 5.2** is an example of how this can be achieved.

NOTE: the open limit switches are connected to COM via the STP switch. This prevents the motors being opened when the stop switch is activated. The stop switch is still connected to the STP input (12) which like the other control and safety inputs responds quicker than the limit switch inputs. This ensures that when the stop switch is activated and the motor drive is turned off via the interlock, the control board responds to the STP input and not the limit switch inputs which would signal that the limits had been reached.

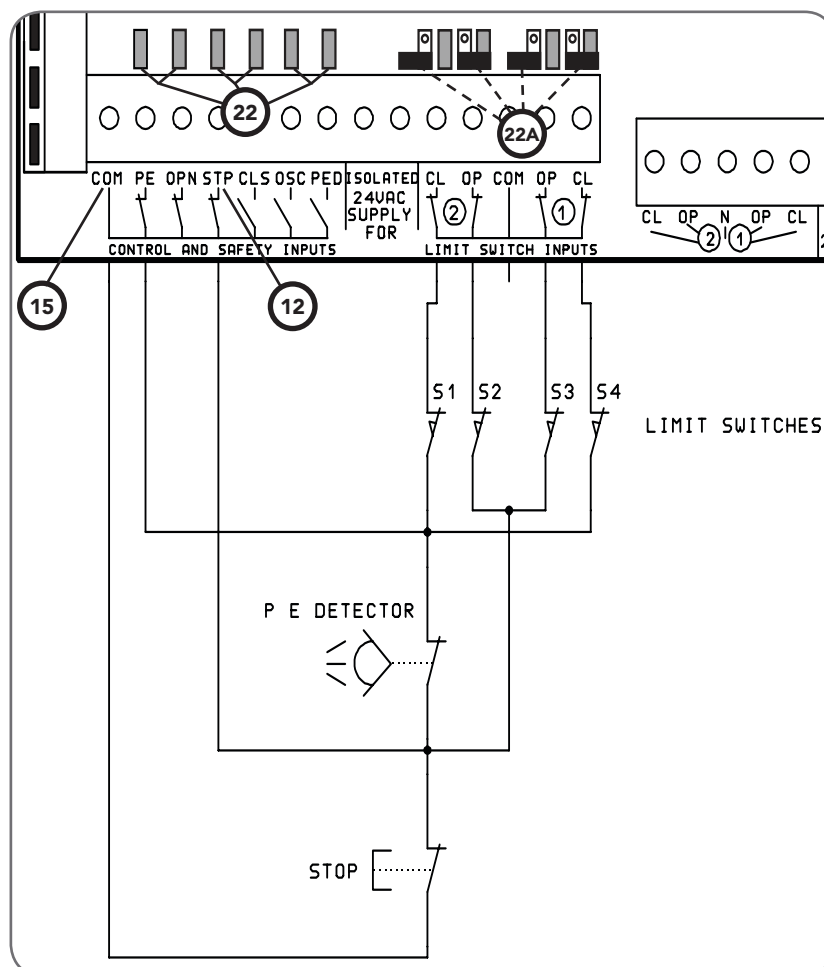

Fig 5.2

5. Wiring Input Terminals

NOTE: the close limit switches are connected to COM via both the P.E detector and the stop switch. This prevents the motors being driven in the close direction if either the stop switch or the P.E detector are activated. The P.E detector is still connected to the P.E input so that the control board can respond appropriately. The open limit switches could be wired the same as the close limit switches in **Fig 5.2** if the P.E is required to prevent the motors opening (P.E STOPS OPEN CYCLE > ON). An open switch could also be interlocked with the close limit switches in a similar way so that the motors could not be closed if the open switch was activated.

NOTE: that this feature can still be utilised if limit switches are not used. Simply follow the example in **Fig 5.2** with the limit switches omitted and place the Clack Shunts (22A) over both pins.

NOTE: the status of the control, safety and limit switch inputs is indicated by the LEDs (22) located behind the input terminal blocks. A particular input terminal's LED will light when that terminal is connected to COM.

6. Wiring Terminals

6.1 Remote Control Receiver Connector

For remote control operation an Automatic Technology remote control plug-in receiver can be plugged into the control board's connector (19). The plug-in receiver operates the control board via a trigger output.

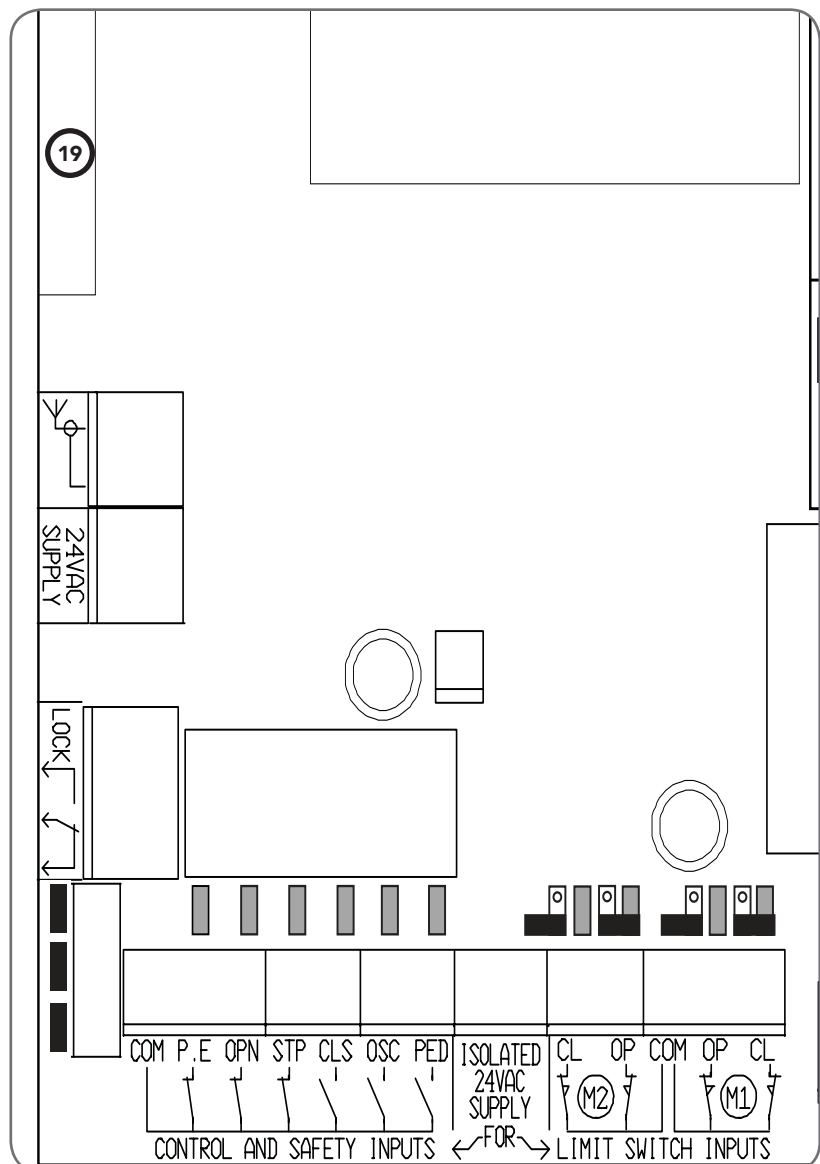

Fig 6.1

7. Wiring Lights

Use the light relay module (if fitted) to switch the applied voltage to a light. The load switched by the light relay module must not exceed 240V A.C / 30V D.C @ 10 Amps.

7.1 Wiring Light Relay Module to Courtesy Warning Light.

Fig 7.1 shows how to connect the optional relay module to the control board's connector (21). It also shows how to wire a light to the relay module. The example shows a 240VAC light but any light of any voltage can be used, provided the relay module is able to switch the required voltage and current. See light relay module specifications in section 9 and Appendix B. The light should not be powered from either of the control board's 24VAC supplies as the large current draw may interfere with the control board's operation.

 **ELECTRICUTION! Make sure that the motors are properly earthed.**

7.2 Wiring M2 Output Lights to show Gate status

Fig 7.2 shows how to connect two 240VAC lights to the control boards motor 2 output to show the status of the gate. If desired only one of the status lights need be connected. The limit switch inputs for motor 2 can be used as extra low voltage off/on control of the status lights.

 **ELECTRICUTION! Make sure that the motors are properly earthed.**

NOTE: Lighting option not available when driving an inverter.

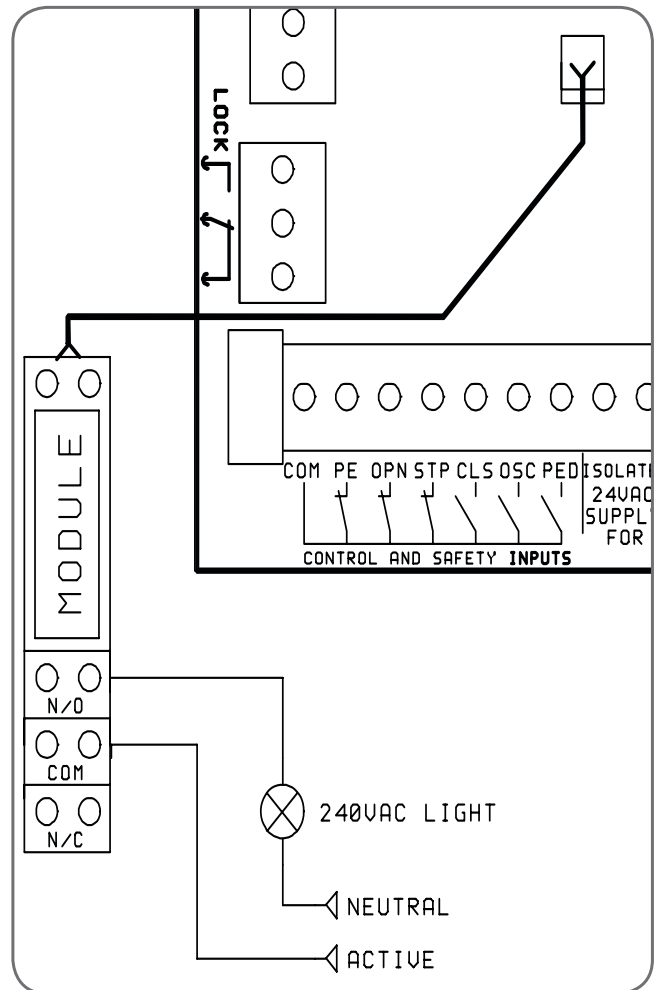

Fig 7.1

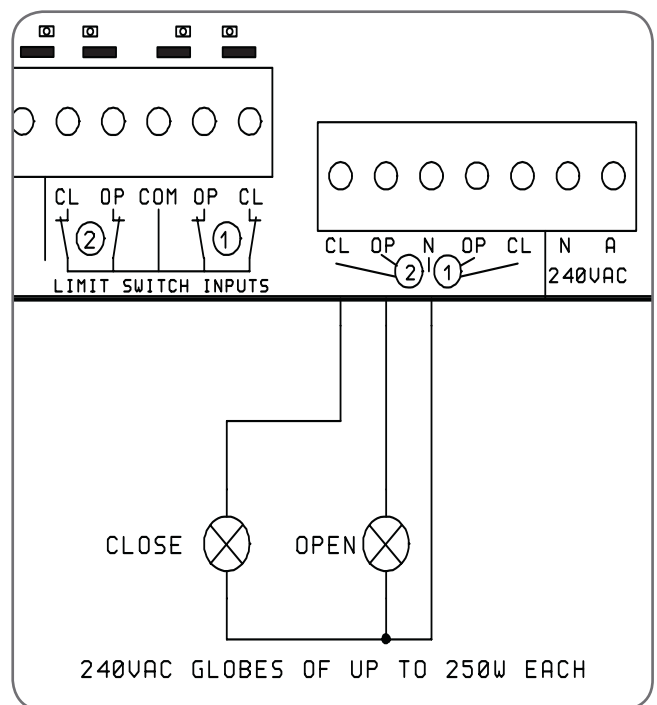
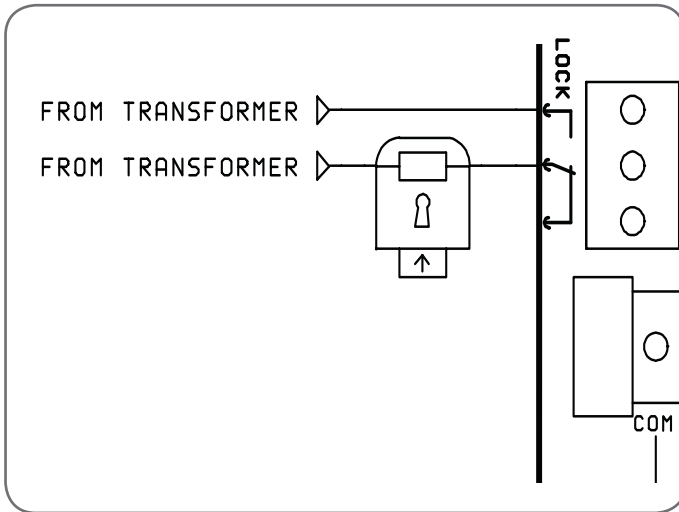

Fig 7.2

8. Wiring Locks

Fig 8.1



Use the lock output terminals to switch the required voltage to an electric lock (if fitted). The load switched by the lock output terminals must not exceed 30V A.C / D.C @ 5Amps. Use a third transformer output to power electric solenoid locks or 12/24V lighting. Automatic Technology can supply a transformer which has three outputs for powering the control board, 24V A.C accessories up to 0.25A and 12V A.C lighting or solenoid locks up to 2.0 amps.

8.1 Lock Release Output for Solenoid Locks

Fig 8.1 shows how to connect an electric solenoid lock (LOPU100 available from Automatic Technology) to the control board's lock release output.

NOTE: the transformer used must be a safety isolating transformer which meets AS3108.

NOTE: the lock release output only switches the applied voltage to the lock and must be "wetted" with the appropriate voltage. The 12VAC output from the transformer supplied from A.T.A is designed to power small pulse action locks such as the LOPU100.



WARNING! Do not use either of the 24VAC supplies connected to the control board to power the lock as the large current draw can interfere with the control boards operation.

Fig 8.2

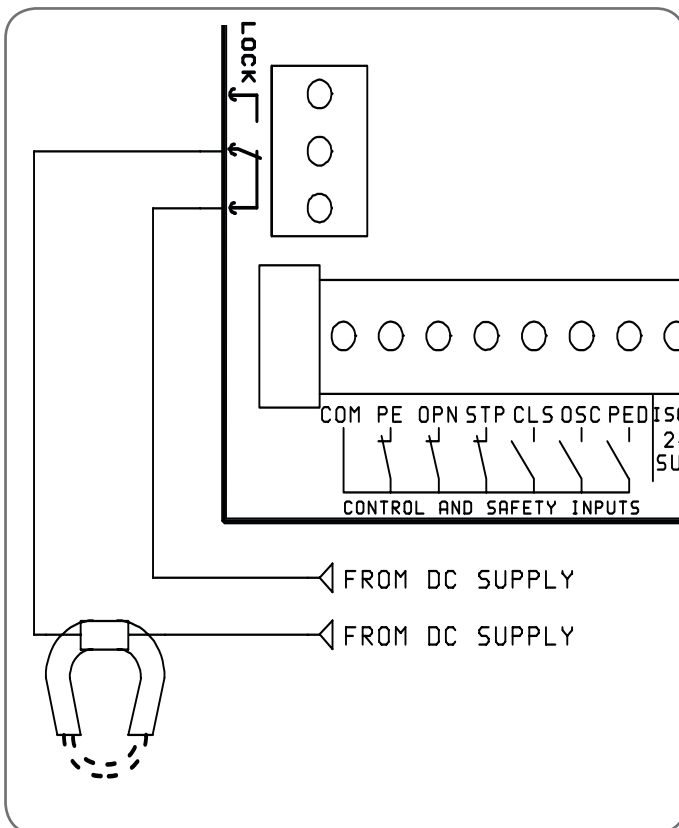

8.2 Lock Release Output for Electromagnetic Locks

Fig 8.2 shows how to connect an electromagnetic lock to the control board's lock release output.

NOTE: the lock release output only switches the applied voltage to the lock and must be wetted with the appropriate voltage.

NOTE: that the lock is connected to the normally closed contact of the lock release output as the lock is energised when the controller is idle and not driving the motors.

9. Mode Selection

Each of the push button switches (26) to (31) have three functions (**Fig 9.1**). The two most commonly used functions are selected by the position of the "RUN / set" slide switch (25) the third function is selected by the special adjustment mode, see Appendix A for details.

9.1 Functions of ON and OFF Switch Positions

Table 9.1 shows the function of each push button with the slide switch in the "ON" and "OFF" positions (23).

Using the mode selection dip-switches select the desired operating modes.

NOTE: the times associated with the parameters marked with an * can be changed. The auto-close times can be changed using the procedure in Section 9.

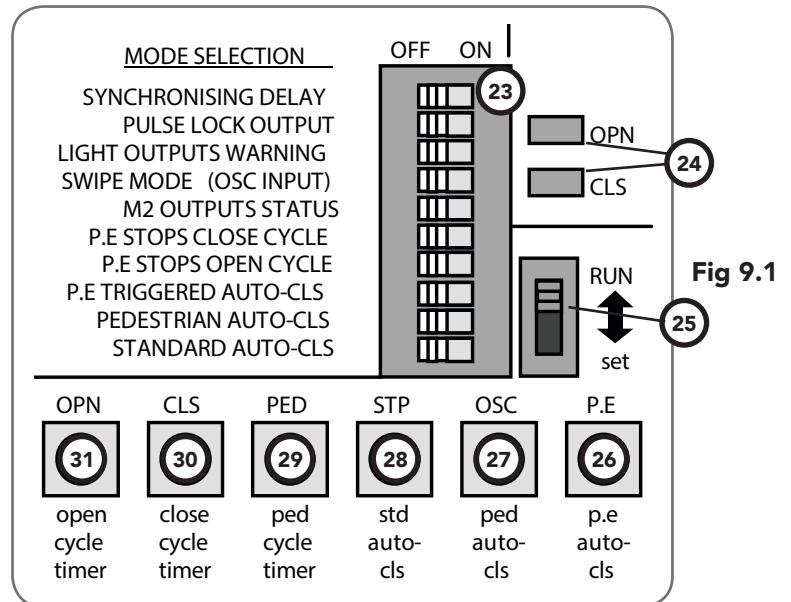

Table 9.1

Mode Selection		
Position 1 - SYNCHRONISING DELAY When dual swing gates are used it is common for a back stop to be mounted on one of the gate leaves so that the gate leaves are aligned when closed. To prevent the gate leaves interfering with each other the gate leaf with the back stop must be made to reach the close position first when closing and be made to start to open last. The controller can be made to do this by placing the mode selection dip-switch labelled "SYNCHRONISING DELAY" into the "ON" position. This will result in the gate leaf driven by motor 1 starting to open 2 seconds before the gate leaf driven by motor 2 and the gate leaf driven by motor 2 starting close 2 seconds before that of motor 1.	OFF	no delay
	ON	Motor 1 starts to open 2 seconds* before Motor 2 and Motor 2 starts to close 2 seconds* before Motor 1.
Position 2 - PULSE LOCK OUTPUT Some locking mechanisms require a quick pulse of power to release. The controller can be made to pulse the lock release output (17) for 0.3 seconds at the start of each cycle. To select this action place the mode selection dip-switch labelled "PULSE LOCK OUTPUT" into the "ON" position. The factory set pulse duration of 0.3 seconds can be changed if desired, see Appendix A for details.	OFF	Lock output is activated for the entire motor drive cycle.
	ON	Lock output pulses for 0.3 seconds* at the start of each drive cycle.
Position 3 - LIGHT OUTPUTS WARNING The light output module can be used to control a warning light. The warning light will be activated whenever the gate is moving. To select this mode place the mode selection dip-switch labelled "LIGHT OUTPUTS WARNING" into the "ON" position.	OFF	Optional light module controls a light with timer which turns light off after 60seconds*.
	ON	Optional light module controls a warning light which activates whenever motors are on.
Position 4 - SWIPE MODE (OSC INPUT) With this mode selected the OSC control input's (10) (and the remote control OSC input) operation is changed so that it only opens the gate. The input can be activated by a switch connected to the OSC terminal (10), by pressing the OSC button (28) or by activating the remote control OSC input using a remote control transmitter.	OFF	OSC input terminal has standard Open, Close, Stop action.
	ON	OSC input terminal will only open the door/gate. The input also resets the P.E triggered auto-close mode so that the P.E input will need to be triggered again before a P.E auto-close cycle will be initiated.

9. Mode Selection

Mode Selection		
<p>Position 5 - M2 OUTPUTS STATUS</p> <p>If only one motor is being controlled, it is possible to use motor 2's output to control two lights which can show the gate's status. This is selected by placing the mode selection dip-switch labelled "M2 OUTPUTS STATUS" into the "ON" position. See Appendix A for more options.</p>	OFF	The Motor 2 output control second motor
	ON	The Motor 2 output controls status lights
<p>Position 6 - PE STOPS CLOSE CYCLE</p> <p>When the mode selection dip-switch labelled "P.E STOPS CLOSE CYCLE" is placed into the "ON" position the P.E input's operation is changed. When the P.E input is activated while the gate is closing the controller stops the gate leaves but does not reopen them.</p>	OFF	Activating the PE inputs while motors are closing causes the motors to reverse.
	ON	Activating the PE inputs while motors are closing causes the motors to stop but no reverse.
<p>Position 7 - PE STOPS OPEN CYCLE</p> <p>When the mode selection dip-switch labelled "P.E STOPS OPEN CYCLE" is placed into the "ON" position the P.E input operation changes. In this mode, when the P.E input is active the controller prevents the motors being driven in either direction.</p>	OFF	Activating the PE input while motors are opening is ignored by the controller.
	ON	Activating the PE input while motors are opening causes the motors to stop.
<p>Position 8 - PE TRIGGERED AUTO-CLS</p> <p>In this auto-close mode the controller will only auto-close the gate if the P.E input (in any mode) has been activated and then released since</p> <ul style="list-style-type: none"> a) the gate was last fully closed, b) the SWIPE (OSC) input was activated, c) the PED input was activated or d) the gate was stopped (stopped by P.E input excluded). <p>The auto-close timer's count down can be suspended by activating the OPN input if the gate is in the open position. The P.E TRIGGERED auto-close mode is selected by placing the mode selection dip-switch labelled "P.E TRIGGERED AUTO-CLS" into the "ON" position. Refer to Appendix A for information on the three (3) different modes.</p>	OFF	Not selected
	ON	Selects the PE triggered auto-close mode which causes the motors to auto-close if the PE input is activated then released. (Auto-close delay time is 30 seconds*)
<p>Position 9 - PEDESTRIAN AUTO-CLS</p> <p>In this auto-close mode the gate will auto-close 15 seconds after being partly opened for pedestrian access. If the PED or P.E inputs are active while the leaf is partly opened for pedestrian access the auto-close timer's count down will be suspended until the inputs are released. If during the pedestrian auto-close cycle the P.E input or the PED input are activated the gate leaf will stop but not reopen. A new count down will be initiated once the inputs are deactivated.</p>	OFF	No Pedestrian access auto-close
	ON	Selects auto-close in the pedestrian access mode (Auto-close delay time is 15 seconds*)
<p>Position 10 - STANDARD AUTO-CLS</p> <p>In this auto-close mode the gate will auto-close 30 seconds after being fully opened. The auto-close timer's count down can be suspended by the OPN and P.E inputs. If the timer's count down has been stopped by the STP input being activated, it can be restarted by activating the OPN input. This mode is selected by placing the mode selection dip-switch labelled "STANDARD AUTO-CLS" into the "ON" position.</p>	OFF	Not selected
	ON	Selects standard auto-close mode which will close the motors after fully opening. (Auto-close delay time is 30 seconds*)

10. PG-3 Programmer Compatible

Once the ON / OFF switch positions for the Mode Selection Dip Switches (23) has been completed in Section 9, depending on the CB-6 version of the board there may be PG-3 Programmer compatibility. Check whether the Adaptor Board (20) on the CB-6 Board has a PG-3 Plug as shown in **Fig 10.1**. If no PG-3 Plug, proceed to Section 12.

10.1 Connect to Device

- Plug the PG-3 cable into the 5-pin plug on the Adaptor Board of the CB-6 Control Board.
- Power on the PG-3, select **CONNECT TO DEVICE**, and press **✓**. The PG-3 will attempt to identify the board, and check if it is supported.
- If the device is supported then a new menu will be displayed with the device details shown at the top.

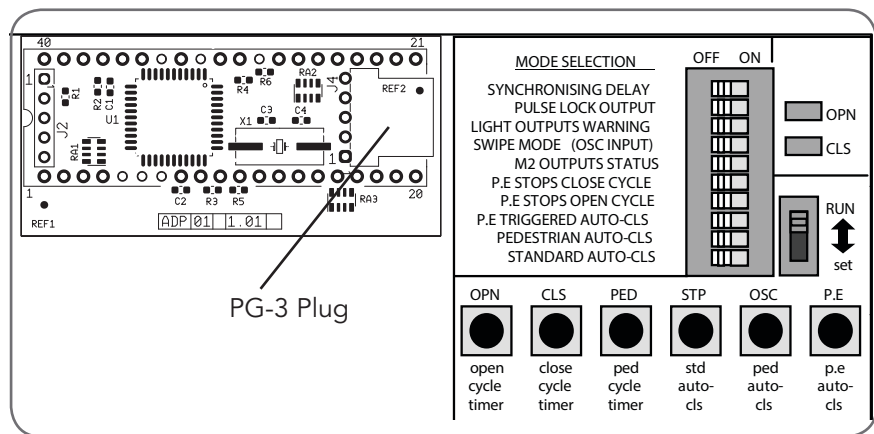

Fig 10.1

10.2 Device Main Screen

Once you have connected to the device the PG-3 will attempt to identify the device it is connected to and display the Main Screen (**Fig 10.2**).

NOTE: The Firmware Upgrade menu item only displays if an upgrade is needed. Alternatively the PG-3 may display the following message "Firmware not supported". In this instance, contact ATA Service on 1300 736 410 to organise a upgrade of your PG-3 Programmer.

10.3 Firmware Upgrade

From time to time new firmware is release for products which provide enhancements or new features. It is often advisable to upgrade products to the latest firmware version available.

The ***FIRMWARE UPGRADE*** menu item only displays when an upgrade is available for the device, and then gives you the option to install it.

NOTE: Firmware upgrades result in the products settings being reset to the factory defaults i.e all installation information will be cleared. Always backup transmitter storages before installing a new version of firmware. Refer to your PG-3 Manual to conduct backup.

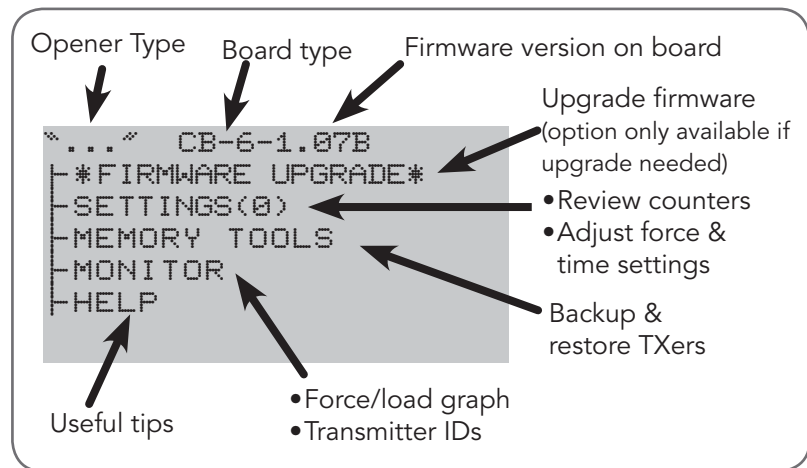

Fig 10.2

11. PG-3 Settings

11.1 Settings

When **SETTINGS** is selected either a sub menu is shown with the setting grouped or the first setting is displayed. When the sub menu is displayed navigate to the desired sub group using the arrow keys and then select it by pressing **✓**. The below three modes describe how settings are displayed, edited and accessed:

DETAIL MODE

When settings details are displayed the setting's name, description and current value are shown. The bottom line of the display shows what options are available. The **←** (LEFT) and **→** (RIGHT) arrows are used to show the next setting in the list of settings, the **X** (CROSS) can be used to go back to the previous menu, the **✓** (TICK) will be shown if the setting can be edited.

EDIT MODE

When settings Edit is selected the information shown depends on the type of setting but will generally show the setting's name and the current value with the last line indicating the options available. **Table 11.1** below shows most options to be shown and their meaning.

ICON	Function
← (LEFT)	Moves cursor left
→ (RIGHT)	Loads the default value
↑ (UP)	For numeric settings: Enters a decimal point For mode settings: Selects the next mode
↓ (DOWN)	For numeric settings: Enters a minus sign For mode settings: Selects the next mode
# (HASH)	Enables number keys to be pressed
X (CROSS)	Exits without saving
✓ (TICK)	Saves new setting

Table 11.1

ACCESS MODE

Some settings are not normally adjusted and should only be changed with caution. To enable the edit option for these settings and to enable the displaying of some advanced settings, the access level must be set to "1" rather than the default "0".

- To select the access level, return to the devices menu where the first item is **SETTINGS**.
- To select a different access level to the one shown, simply press and hold the power button just prior to selecting the **SETTINGS** menu item.
- When this is done an access level screen is shown which allows access level 1 to be selected.
- The new access level will remain active until the PG-3 is turned off.

11.2 Programming CB-6 Board via settings

Once connected to the CB-6 Board and you have entered the EDIT mode of the Settings function (Section 10.4) you will be able to access the settings in **Fig 11.2** and make your desired special adjustments without having to follow Appendix's A - D. All the adjustments are made from the PG-3 Programmer.

```

-OPEN DRIVE TIME
-CLOSE DRIVE TIME
-PED DRIVE TIME
-P.E A/CLOSE TIME
-PED A/CLOSE TIME
-STD A/CLOSE TIME
-LOCK PULSE TIME
-PRE DRIVE LOCK
-PRE DRIVE WARNING
-COURTESY LIGHT TIME
-MOTOR STOPPING TIME
-OPN GATE SYNC RELAY
-CLS GATE SYNC RELAY
-ANTI JAM CLOSE MODE
-ANTI JAM OPEN MODE
-TIMED RETURN MODE
-PED TIMED RETURN MODE
-TIMED RETURN +25%
-PED = OSC ACTION MODE
-PED = SWIPE ACTION
-EXIT P.E AUTO-CLS
-OPN = INSIDE P.E INPUTS
-P.E = OUTSIDE P.E INPUTS
-TORQUE MTR MODE
    
```

Fig 11.2

12. Cycle and Autoclose Times

The factory set default drive cycle times as well as the auto-close times can be adjusted to suit the needs of each installation. When the slide switch (25) is placed into the "set" position, the buttons (26) through (31) are used to set the cycle and auto-close times. The method is the same for each time to be set and involves pressing and holding the appropriate button for the required duration. The time the button is held down for is then stored within the controller's memory and used when the controller is in the "RUN" mode. When the motor drive cycle times are being set the controller also drives the motors as if a real drive cycle is being executed. The difference being that the motors stop as soon as the button is released. This feature can be used to help adjust and test the limit switch positions by "inching" the motors open and closed. To aid adjustment of the auto-close timers the CLS status led (24) illuminates to indicate when timing adjustment starts and the OPN status led (26) flashes at one second intervals while the button is pressed. Make sure that the slide switch (25) is placed into the "RUN" position after each required timer has been adjusted and before trying to test the new values.

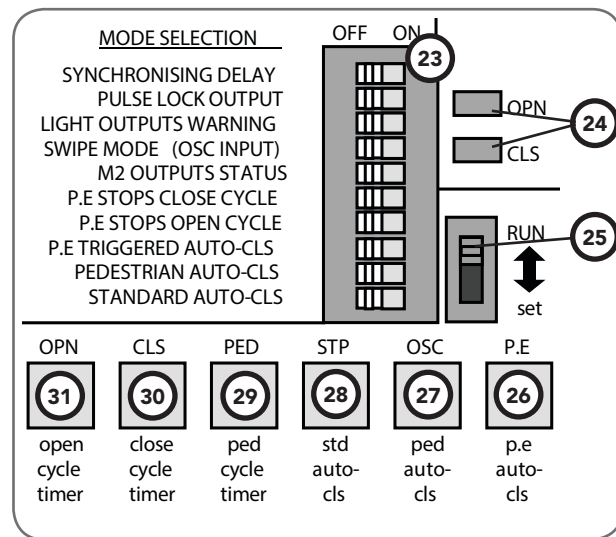

Fig 12.1

12.1 Setting Open, Close and Pedestrian Access Cycle Times

Follow the steps below to set the open, close and pedestrian access cycle times.

- Place the slide switch (25) into the "set" position.
- Close the gate by pressing and holding the "close cycle timer" button (30) until both motors are closed.
- To set the open cycle time press and hold the "open cycle timer" button (31) until the gate has reached the desired open position, or if limit switches are used wait until a few seconds after the limit switches are reached before releasing.
- To set the close cycle time press and hold the "close cycle timer" button (30) until the gate has reached the desired closed position, or if limit switches are used wait until a few seconds after the limit switches are reached before releasing.
- Go to step (g) if pedestrian access is not used.
- To set the pedestrian access part open position press and hold the "ped cycle timer" button (29) until the gate leaf driven by motor 1 has opened far enough for pedestrian access.
- Place the slide switch (25) into the "RUN" position and test operation.

The open, close and pedestrian access cycle times can be set individually if desired by placing the gate in the desired starting position and then moving the slide switch into the "set" position and pressing the appropriate button. Make sure the slide switch is placed back into the "RUN" position before testing operation.

12.2 Setting P.E Triggered Autoclose Delay Time

Follow the steps below to set the P.E triggered auto-close delay time.

- Place the slide switch (25) into the "set" position
- Press and hold the "p.e auto-cls" button (26) for the required delay time.
- Place the slide switch (25) into the "RUN" position and test operation.

12.3 Setting Pedestrian Access Autoclose Delay Time

Follow the steps below to set the pedestrian access auto-close delay time.

- Place the slide switch (25) into the "set" position.
- Press and hold the "ped auto-cls" button (27) for the required delay time.
- Place the slide switch (25) into the "RUN" position and test operation.

12.4 Setting Standard Autoclose Delay Time

Follow the steps below to set the standard auto-close delay time.

- Place the slide switch (25) into the "set" position.
- Press and hold the "std auto-cls" button (28) for the required delay time.
- Place the slide switch (25) into the "RUN" position and test operation.

13. Autoclose Modes

The auto-close modes automatically close the gate after it has been operated. To implement this the controller sets an internal timer once the gate has reached its desired open position. The timer then counts down and when it expires the controller starts to close the gate. The timer's count down can be suspended by activating the P.E input or other inputs depending on the mode selected. When the suspending input is deactivated the timer is reloaded and the count down recommenced. The timer's count down can be stopped altogether by activating the STP input. See Section 9 position 8,9 10 and below for details about the three auto-close modes (11.3). and **Fig 13.1**.

13.1 Autoclose after reaching the Open Position

In this auto-close mode the gate will auto-close 30 seconds after being fully opened. The auto-close timer's count down can be suspended by the OPN and P.E inputs. If the timer's count down has been stopped by the STP input being activated, it can be restarted by activating the OPN input. This mode is selected by placing the mode selection dip-switch labelled "STANDARD AUTO-CLS" ① into the "ON" position.

13.2 Autoclose after being opened for Pedestrian Access

In this auto-close mode the gate will auto-close 15 seconds after being partly opened for pedestrian access. If the PED or P.E inputs are active while the leaf is partly opened for pedestrian access the auto-close timer's count down will be suspended until the inputs are released. If during the pedestrian auto-close cycle the P.E input or the PED input are activated the gate leaf will stop but not reopen. A new count down will be initiated once the inputs are deactivated.

This mode is selected by placing the mode selection dip-switch labelled "PEDESTRIAN AUTO-CLS" ② into the "ON" position.

13.3 Autoclose after cycle if PE has been triggered ③

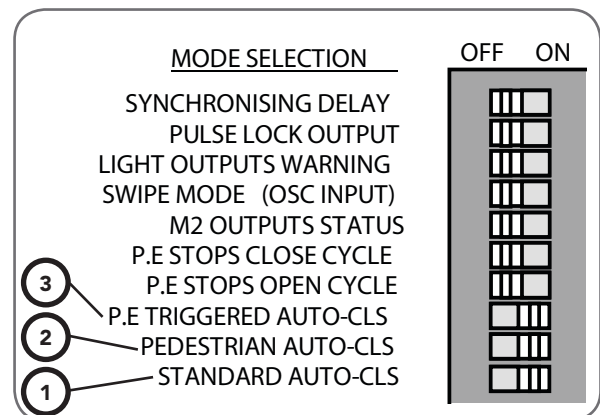

Fig 13.1

PE Modes				
PE in Standard Mode	PE TRIGGERED AUTO-CLS	ON	The controller will auto-close the gate from the open position provided the P.E input was activated while the gate was opening or in the open position.	
	PE STOPS OPEN CYCLE	OFF		
	PE STOPS CLOSE CYCLE	OFF		
PE Stops Close Cycle	PE TRIGGERED AUTO-CLS	ON	The controller will auto-close the gate if the P.E input was activated while the gate was opening or is activate while the gate is open. In addition it will also auto-close the gate if the P.E input is activated while the gate is closing, in which case the gate stops and then auto-closes from its stopped position when the P.E input is deactivated.	
	PE STOPS CLOSE CYCLE	ON		
PE Stops Open Cycle	PE TRIGGERED AUTO-CLS	ON	The controller will auto-close the gate if the P.E input is activated while the gate is open. In addition it will also auto-close the gate if the P.E input is activated while the gate is closing or opening, in which case the gate stops and then auto-closes from its stopped position once the P.E input is deactivated.	
	PE STOPS OPEN CYCLE	ON		

13.4 Mixing Autoclose modes

Mode Selection		
PEDESTRIAN AUTOCLOSE	ON	In this case the gate would partly open for pedestrian access and then either the PE TRIGGERED AUTO-CLS would cause the gate to autoclose when a pedestrian walks through and activates the P.E beam or, if no one walked through the PEDESTRIAN AUTO-CLS would close the gate. This way the gate is only kept open long enough for a person to walk through, but with the backup that if no one walks through the gate will still close.
PE TRIGGERED AUTOCLOSE	ON	
STANDARD AUTOCLOSE	ON	The gate would only stay open long enough for the vehicle to pass through but would still auto-close if no vehicle enters.
PE TRIGGERED AUTOCLOSE	ON	

14. Specifications

Technical Specifications		Minimum	Maximum
Supply Voltages	240 VAC Supply		450V peak
	24 VAC Supply		29VAC
Input Voltages	Control and Safety Inputs	-50 Volts	100 Volts
	Limit Switch Inputs	-50 Volts	100 Volts
Outputs	Lock Output (switching voltage)		30 VAC / DC
	Lock Output (switching current [inductive])		3 AMPS
	Light Output Module (switching voltage)		240 VAC / 30 VDC
	Light Output Module (switching current)		10A AC / DC
	Total Motor Output Current		5 AMP (5 AMP fuse protected)

NOTE: Exceeding these values may cause serious damage to the control board. These are fault rating not normal operating conditions.

NOTE: Note that the maximum ratings shown below are an indication of the input's ability to withstand being incorrectly connected to an external voltage source. In normal operation NO voltage should be connected to the control board's inputs. Although the inputs will not be damaged by an input voltage less than or equal to the maximum rating it is not implied that the control board will function correctly while that input is under such a condition.

Typical Requirements and Characteristics		
Power Supply Requirements	Isolated 24 VAC Supply	22 - 26 VAC @ 250mA max
	24 VAC Supply	22 - 26 VAC @ 250mA max
	240 VAC Supply	240 VAC @ 5A max (or lower if required by motor)
OPN, STP, OSC, PED Inputs	Logic low input current	5mA DC (input shorted to COM terminal)
	Logic high input current	0mA DC (input open circuit)
	Logic low / high threshold	2.5mA DC
	Response time	0.1secs
CLS Input	Logic low input current	10mA DC (input shorted to COM terminal)
	Logic high input current	0mA DC (input open circuit)
	Logic low / high threshold	5mA DC
	Response time	0.1secs
Limit Switch Inputs	Logic low input current	20mA DC (input shorted to COM terminal)
	Logic high input current	0mA DC (input open circuit)
	Minimum low level input current	16mA DC (300 ohm resistor from input to COM terminal)
	Response time	0.2secs (This is microcontroller's response time. The limit switches are interlocked with the motor drive and therefore act immediately)

15. Troubleshooting

Symptom	Possible cause	Remedy
Opener will not operate	Wiring to Outputs / Inputs incorrect.	Check wiring.
Opener does not work from transmitter	Transmitter code not stored in receiver.	Code transmitter in to receiver.
	Flat battery in transmitter	Replace battery
CB-6 not operating from OPEN, CLOSE, OSC Buttons and both status lights are flashing	Disconnected Shunts	Check PE, OPEN, STOP inputs use only normally close contacts. IF PE or OPEN or STOP inputs are not used, ensure three black shunts are on. This can be confirmed by watching the three leds behind PE, OPEN, STOP terminal, which should be lit.
Green Status LED is flashing but gate not moving	Faulty Fuse	Check Fuse
Red Light flashing but gate not closing	Faulty Fuse	Check Fuse
Gate ignoring the limit switches	Shunt not removed	Remove the shunt from behind the limit witch input terminal
Lights behind limit terminal not lit and gate not moving	Wrong switches / Wiring problem	Use normally close limit switches and check wiring
Transmitter not working	Transmitter not coded into unit	Install a receiver and code the transmitter in to receiver
Pedestrian mode not working from transmitter	Transmitter not coded in the second channel of the receiver	Code transmitter in to receiver
Gate stops short of set limits	Limits not set properly	Reset limits
Auto Close not working	Safety Beam not aligned properly. Auto Close timer not adjusted. PE Trigger or Std Autoclose dip switch is not in the on position.	Check Alignment Check Auto Close settings (Section 13.3) Check switches.

16. Appendix

A - Special Adjustments

In order to make some of the less common adjustments the control must be placed into the special adjustment mode. This is done by following:

- Turn the control board's power off
- Place the slide switch (25) into the "set" position
- Press and hold the CLS button (30)
- Turn the control board's power on.
(Keep holding the CLS button)
- Wait until both the status LEDs (24) turn off and then release the CLS button (30).
- Both the status LEDs (24) will come on to indicate that the special adjustment mode is selected.

The controller is now ready to adjust the special parameters. Steps below give details on the adjustments and how to make them. Make sure the slide switch (25) is placed into the "RUN" position after adjustment.

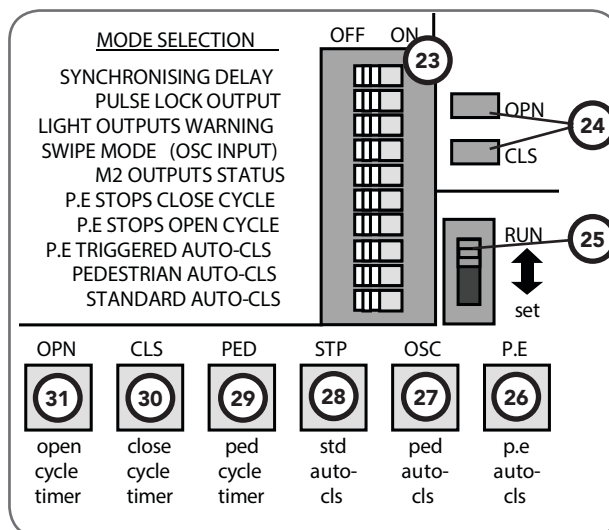

Fig A.1

NOTE: To aid adjustment the status LEDs (24) will both be turned off when timer adjustment starts and the CLS status led (24) will flash at one second intervals while the button is pressed.

NOTE: For a summary of all adjustments see Table B.1 in Appendix B.

Setting Lock Pulse Length

The lock pulse time is the time the controller activates the lock release output for at the start of each cycle. The adjustment only applies when the PULSE LOCK OUTPUT dip-switch is in the ON position. To set the pulse time - Press and hold the OPN button (31) for the required lock pulse time.

Setting Time from when Warning Light is Activated to when Motors are started

The controller can be made to turn the warning light on before the motors are started. To adjust the duration of the delay - Press and hold the CLS button (30) for the required pre-drive delay time.

NOTE: the LIGHT OUTPUTS WARNING dip-switch must be on.

Setting Courtesy Light Timer Duration

To set the courtesy light timer duration - Press and hold the CLS button (30) for the required light timer duration.

NOTE: that each second the button is held represents 10 secs for timer, ie., holding the button for 6 secs will set the timer to 60 secs.

NOTE: the LIGHT OUTPUTS WARNING dip-switch must be off.

Setting Motor Stopping Time

The time the motors are given to come to rest after being switched off is adjusted by - Pressing and holding the STP button (28) for the required motor stopping time.

Setting Time from when Lock Release Output is activated to when Motors are started

The controller can be made to activate the lock release output before the motors are started. To set the duration of the pause - Press and hold the OSC button (27) for the required pre-drive lock activation time.

Setting Duration of Gate Leaf Synchronising Delay

To adjust the gate leaf synchronising delay - Press and hold the P.E button (26) for the required synchronising delay time. This adjustment overwrites the close synchronising delay set using the below step.

Setting Duration of Closing Gate Leaf Synchronising Delay

To adjust the gate leaf synchronising delay for the close cycle only - Press and hold the PED button (29) for the required synchronising delay time. This adjustment does not affect the synchronising delay set for the open cycle. To set the open and close synchronising delays to different values, set the open cycle synchronising delay using the "Gate Leaf Synchronising Delay" step above and then set the close synchronising delay using this step.

Appendix

B - Operating Parameters

The operating parameters that can be changed by the user are listed below in Table B.1.

- The "ADJUSTMENT METHOD" states the button and adjustment mode required to change the parameter's value.
- The "FACTORY" value is programmed into the control board during manufacture or can be reloaded into the controller's memory by using the steps in Appendix C.
- The "RANGE" is the range of values the parameter can be programmed to be.
- The "STEP" is the smallest adjustment that can be made to a parameter's value. All values are in seconds.
- The "SECTION" states which part of this manual will provide details on how to execute the Parameter.

NOTE: that the PRE-DRIVE WARNING ACTIVATION TIME and the COURTESY LIGHT TIME are both adjusted using the CLS button in the special adjustment mode (see Appendix A). The position of the LIGHT OUTPUTS WARNING dip-switch determines which of the two parameters is being adjusted.

Parameter	Adjustment Method	Factory	Range	Step	Section
Open Cycle Time	open cycle timer [set]	60	0-6553	0.1	10.1
Close Cycle Time	close cycle timer [set]	60	0-6553	0.1	10.1
Pedestrian Cycle Time	ped cycle timer [set]	5	0-6553	0.1	10.1
P.E Triggered Autoclose Time	p.e auto-cls [set]	0	0-6553	0.1	10.2
Pedestrian Autoclose Time	ped auto-cls [set]	15	0-6553	0.1	10.3
Standard Autoclose Time	std auto-cls [set]	30	0-6553	0.1	10.4
Lock Pulse Length	OPN [special adj mode]	0.3	0-6553	0.1	Appendix A
Pre-Drive Lock Activation Time	OSC [special adj mode]	0	0-6553	0.1	Appendix A
Pre-Drive Warning Activation Time	CLS [special adj mode]	0	0-25.5	0.1	Appendix A
Courtesy Light Time	CLS [special adj mode]	60	0-6553	0.1	Appendix A
Motor Stopping Time	STP [special adj mode]	0.5	0-25.5	0.1	Appendix A
Gate Synchronising Delay	P.E [special adj mode]	0 (2)	0-25.5	0.1	Appendix A
Gate Synchronising Delay (Close)	PED [special adj mode]	0 (2)	0-25.5	0.1	Appendix A

Table B.1

C - Reloading Memory with Factory Default Times

The control board comes programmed with factory set values for all of its operating parameters. These values can be reloaded back into the controller's memory by following the steps below.

- Turn the control board's power off
- Place the slide switch (25) into the "set" position
- Press and hold the CLS button (30)
- Turn the control board's power on.
(Keep holding the CLS button)
- Wait until both the status LEDs (24) turn off .
- While still holding the CLS button (30) place the slide switch (25) into the "RUN" position.
- Wait until the OPN status led (24) is turned on.
- Release the CLS button (30).
- Wait for status LEDs (24) to start flashing - Now ready to be used.

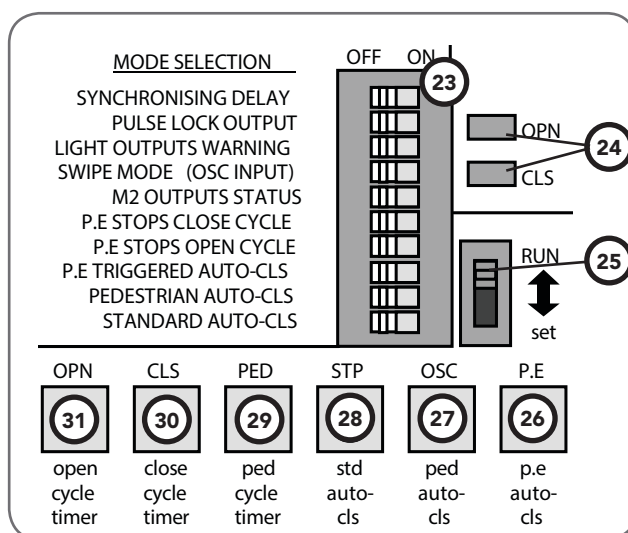

Fig C.1

NOTE: that the controller is normally supplied with all mode selection dip-switches in the "OFF" position and the slide switch in the "RUN" position. However check the instructions of the access controller purchased.

Appendix

D - Specialised Operating Modes

As there are countless ways of controlling motorised devices the CB-6 has been designed so that it can be easily upgraded to accommodate new functions and modes of operation as required. To select one or more of these "specialised operating modes" simply:

- a. Turn the power to the control board off.
- b. Set the dip-switches (23) as required to select the required specialised operating modes (shown in **Table D.1**).
- c. Place the RUN / set switch (25) into the "set" position.
- d. Press and hold the "CLS" button (30). (Don't release the "CLS" button until step "h").
- e. Turn on the power to the control board while holding the "CLS" button. (Both status LEDs (24) will turn on).
- f. Wait for the status LEDs (24) to turn off and then place the RUN / set switch (25) into the "RUN" position.
- g. Wait for the "OPN" status LED (24) to light and then place the RUN / set switch (25) into the "set" position.
- h. Wait for the "OPN" status LED (24) to turn off and the "CLS" status LED (24) to turn on and then release the "CLS" button (30).
- i. Wait until both the status LEDs (24) have turned off.
- j. The selected specialised operating modes are now loaded.
- k. Turn the power to the control board off and then continue to set the control board up as per normal.

NOTE: if a control board is to be returned to the factory set "state" follow the instructions in Appendix C. The currently available specialised operating modes are shown in **Table D.1** below. As the number of modes is growing all the time it may be best to check with ATA or one of their distributors if you don't see the mode you desire.

Dip-Switch Number	Specialised Operating Mode Description	Implemented from Code Version †
1 > ON	ANTI JAM CLOSED (drives gate in closed direction for 0.5s before opening). Only suitable for non-limit switch operators. The Lock output [17] is not activated until the actual open cycle is started.	1.05
2 > ON	ANTI JAM OPEN (drives gate in open direction for 0.5s before closing). Only suitable for non-limit switch operators. The Lock output [17] is not activated until the actual close cycle is started.	1.05
3 > ON	TIMED RETURN (only allows the time driven in an interrupted cycle for the return party cycle). The exact time allowed is the time travelled plus ~12.5%.	1.05
4 > ON	OPTIONAL TIMED RETURN OVERRUN TIME Overrun time of 25% selected instead of standard 12.5%.	1.05
5 > ON	TIMED RETURN FOR PEDESTRIAN ACCESS with 12.5% overrun time.	1.05
6 > ON	PED has an Open / Stop / Close action in pedestrian access mode. Also P.E reverses pedestrian close cycle if P.E STOPS CLOSE CYCLE dip-switch is 'off'.	1.05
7 > ON	PED inputs have swipe action in pedestrian access mode.	2.10
8 > ON	TORQUE MOTOR MODE - in this mode when cycle is completed the motor outputs are not turned off.	
9 > ON		
10 > ON	DIRECTIONAL PE TRIGGERED AUTO CLOSE MODE - in this mode PE triggered auto close mode only activated on exit of vehicle.	

† The large chip "U4" on the control board has the code version marked on it.

Table D.1

Appendix

E - Powering Control Board (no control box)

Powering the Control Board (preferred method)
 The control board has two 24VAC supply inputs. The control supply (18) is used to power the control circuits while the 24VAC supply (8) is used to power the control, safety and limit switch inputs as well as the motor control relays. The two halves of the control board are electrically isolated from each other so that any electrical "noise" picked up by the wiring associated with the control, safety or limit switch inputs is prevented from interfering with the control circuits. **Fig E.1** shows how to connect the two 24VAC transformer outputs to the control board. The 240VAC input is used to power the motors connected to the control board. If a lower voltage motor supply is required then it can be connected to the 240VAC A and N terminals instead. The 12VAC transformer output is provided to power an electric lock or other devices (if required).

WARNING! The transformer used must be a safety isolating transformer which meets AS3108.

ELECTROCUTION! All 240V A.C. wiring must be performed by a licensed electrician. Make sure that the control box is properly earthed.

Powering the Control Board (economy method)
 If the control, safety and limit switch inputs are not used or the associated wiring is very short (<0.5m) and kept away from sources of electrical interference, the control board can be powered as shown in **Fig E.2**. Note both the control board's 24VAC supplies are powered from a single secondary transformer. It should also be noted that the transformer should not be used to supply any other device, for example electric lock, lights, photoelectric beam, etc. The transformer should also be located close to the control board. The 240VAC input is used to power the motors being controlled. If a lower motor supply voltage is required it can be connected to the 240VAC A and N terminals instead of 240VAC.

WARNING! The transformer used must be a safety isolating transformer which meets AS3108.

ELECTROCUTION! Make sure that the control box is properly earthed.

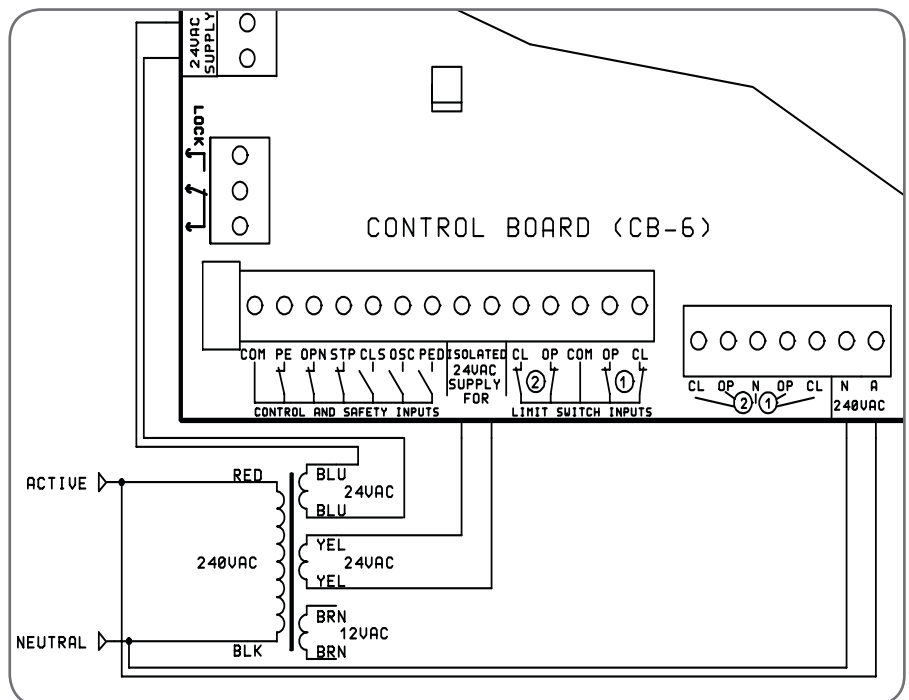

Fig E.1

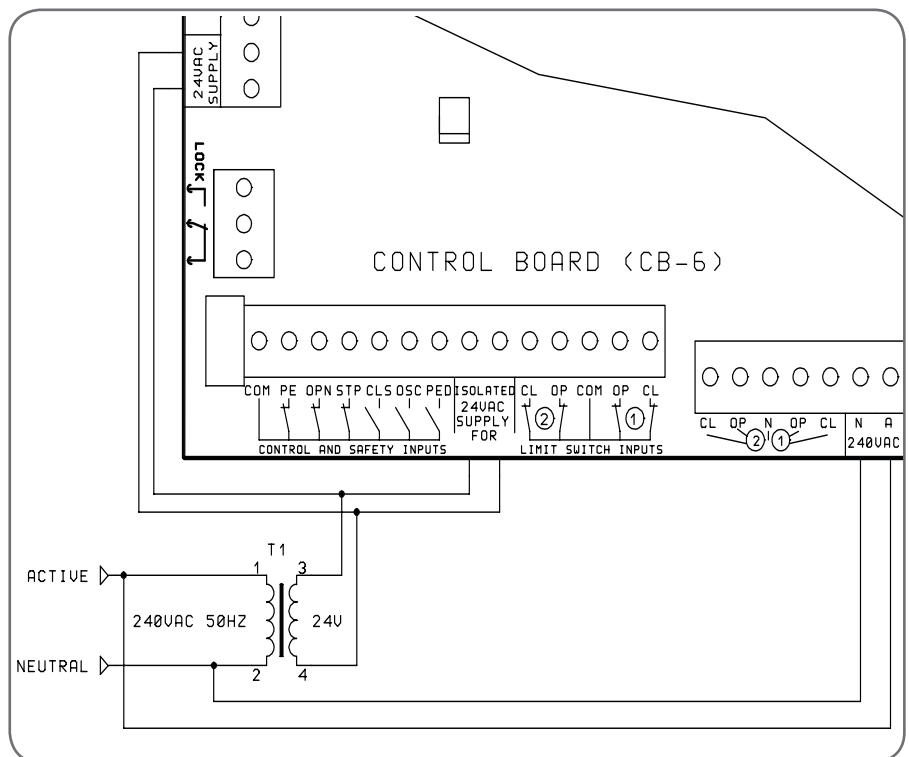

Fig E.2

17. Warranty and Exclusion of Liability

1. This warranty is an addition to any non-excludable conditions or warranties that are implied into this contract by relevant statute, including the Trade Practices Act 1974 (Cwth).
2. Subject to all of the matters set out below, Automatic Technology Australia Pty Ltd ("ATA") warrants:
 - (a) The CB-6 Control Box for twelve (12) months from the date of purchase (specified in the sales docket receipt) as free of any defects in material and workmanship.
 - (b) no further warranty will apply for goods repaired under warranty
 - (c) for all products repaired outside the warranty period, a six months warranty applies from the date of dispatch.
3. This warranty applies only where the purchaser:
 - (a) immediately notifies ATA or the retailer of the alleged defect;
 - (b) returns the product to the retailer; and
 - (c) presents the relevant sales docket and this warranty document to the retailer to confirm the date of purchase.
4. Except for this warranty, ATA gives no warranties of any kind whatsoever (whether express or implied), in relation to the product, and all warranties of whatsoever kind relating to the product are, to the extent permissible by statute, hereby excluded.
5. To the extent permissible by statute, ATA disclaims any liability of whatsoever nature in respect of any claim or demand for loss or damage which arises out of:
 - (a) accidental damage to or normal wear and tear to the product or to the product's components;
 - (b) any cost relating to damage resulting from wear and tear;
 - (c) blown fuses, loss or damage caused by electrical surges, power surges or power spikes;
 - (d) loss or damage due to theft, fire, flood, rain, water, lightning, storms or any other acts of God;
 - (e) evidence of unauthorised repairs;
 - (f) any cost relating to damage caused by misuse, negligence or failure to maintain the equipment in a proper working order as per clauses (d) through (h);
 - (g) installation, adjustment or use which is not in accordance with the instructions set out in installation instruction manual
 - (h) attempted or complete modification or repairs to the product carried out by a person who is not authorised or has not been trained by ATA to carry out such modification or repairs;
 - (i) faulty or unsuitable wiring of structure to which the product is fixed or connected;
 - (j) radio (including citizen band transmission) or any electrical interference;
 - (k) damage caused by insects;
 - (l) loss or damage to any property whatsoever or any loss or expense whatsoever resulting or arising there from or any consequential loss;
 - (m) any cost or expense arising due to manufacturer recall of any product;
 - (n) any cost or expense due to negligence of the approved service provider;
6. ATA's liability under this warranty is limited, at ATA's absolute option, to replacing or repairing the product which ATA, in its unfettered opinion, considers to be defective either in material and/or workmanship or to credit the dealer with the price at which the product was purchased by the dealer.
7. This warranty does not extend to cover labour for installation.
8. This warranty is limited to Return-to-Base (RTB) repair and does not cover labour for on-site attendance.
9. This warranty is void if the Product is not returned to the manufacturer in original or suitably secure packaging.
10. This warranty is only applicable for repairs to the product carried out within Australia.
11. This warranty does not cover consumable items including globes, batteries and fuses.
12. This warranty is not transferable.
13. Where the Product is retailed by any person other than ATA, except for the warranty set out above, such person has no authority from ATA to give any warranty or guarantee on ATA's behalf in addition to the warranty set out above.

©Feb 2015 Automatic Technology (Australia) Pty Ltd.
All rights reserved. TrioCode™128 is a trademarks of Automatic Technology (Australia) Pty Ltd
No part of this document may be reproduced without prior permission. In an ongoing commitment to product quality we reserve the right to change specification without notice. E&OE.

automatic
TECHNOLOGY

Automatic Technology (Australia) Pty Ltd

ABN 11 007 125 368

6-8 Fiveways Boulevard
Keysborough, Victoria, 3173, Australia

P 1300 133 944

E sales@automatictechnology.com.au

www.automatictechnology.com.au

SMART
SIMPLE
SECURE