

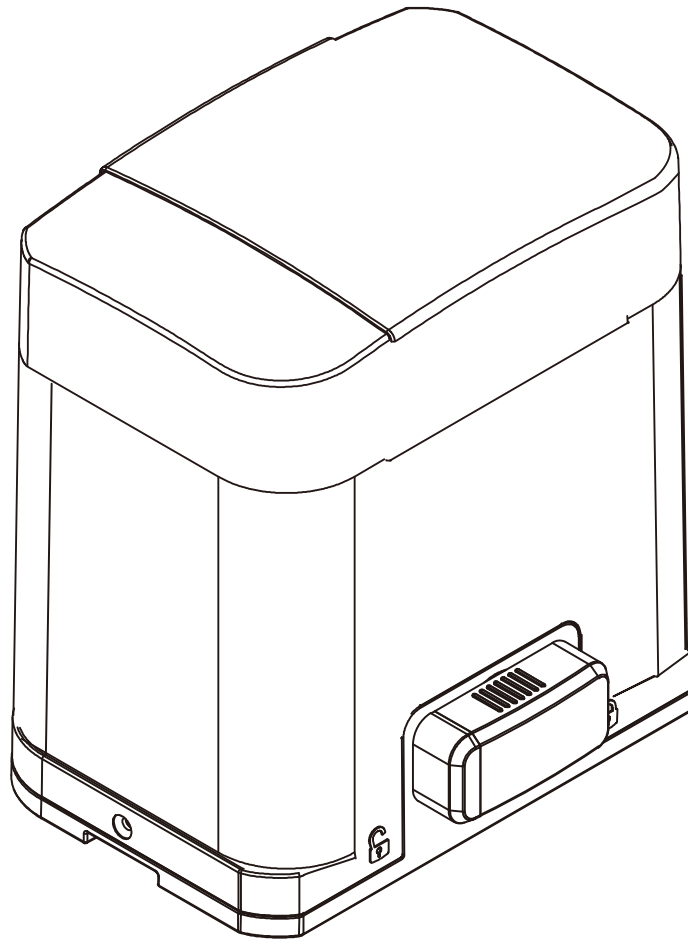

NeoSlider™

NES-500 & NES-800 Sliding Gate Openers



Featuring **TrioCode™ 128** Technology

automatic
TECHNOLOGY

NeoSlider™

Sliding Gate Opener NES-500 / NES-800

Contents

1. Important Safety Instructions	3	10. Coding Transmitter	11
2. Control Board Layout	4	10.1 Coding Transmitter Button	11
3. Set Up Requirements	5	10.2 Selecting Function Of The Button	11
3.1 Kit Contents	5	10.3 Returning To Main Screen	11
3.2 Choosing your Set up	5	10.4 Selecting The Function To Be Coded	11
3.3 Initial Checking	5	11. Emergency Release	12
4. Drive Unit Installation	6	11.1 Your gate CAN NOT be used by the opener when:	12
4.1 Mounting the Drive Unit	6	11.2 Your gate CAN be used when:	12
4.2 Installing antenna	6	11.3 To Disengage the Opener:	12
5. Rack & Limit Actuator Installation	7	11.4 To Re-Engage the Opener:	12
5.1 Mounting rack to gate	7	12. Setting Pedestrian Position	12
5.2 Fixing limit actuator to rack TM	8	12.1 Setting pedestrian position	12
6. Programming The NeoSlider	8	12.2 Pedestrian Position Set	12
6.1 Common Programs	8	12.3 Error Displays	12
6.2 Powering up the NeoSlider™	8	13. Auto-Close Mode	13
7. Safety Beams	8	13.1 Setting Up Standard Auto-Close	13
7.1 Installation of Safety Beams to the NeoSlider™	8	13.2 Safety Beam Triggered Auto Close	13
7.2 Safety Beam Failure Emergency Close (SBFEC)	8	13.3 Pedestrian Auto-Close	13
8. Setting Limits	9	13.4 Auto-Close After Obstruction	13
8.1 Setting Travel Limits	9	14. Accessories Installation	14
8.2 Setting the left/right installation side settings	9	14.1 Fitting Solenoid Or Magnetic Locks	14
8.3 Setting close travel limit	9	14.2 Fitting Courtesy Lights	14
8.4 Setting open travel limit	9	15. Battery Replacement	15
8.5 Automatic limit adjustment and load profile	9	16. Battery Disposal	15
8.6 Pedestrian access position	9	17. Specifications	16
8.7 Errors during setting of travel limit	9	18. Troubleshooting	17
8.8 Recalculate Force Margins	9	19. Appendix	18
9. Safety Obstruction Force Test	10	A - Console Menu Structure	18
9.1 Testing Close Cycle	10	B - Viewing & Editing Parameters	20
9.2 Testing Open Cycle	10	C - Wiring Dual NeoSlider Kit	21
9.3 Force Pressure For Close and Open Cycle.	10	D - Control Board Adjustments	22
9.4 Reprofile Travel	10	E- Diagnostic Tools	23
		F - Memory Tools	24
		G- Transmitter Editing	25
		H- Transmitter Management	26
		20. Warranty and Exclusion of Liability	27

Automatic Technology Australia Pty Ltd to the extent that such may be lawfully excluded hereby expressly disclaims all conditions or warranties, statutory or otherwise which may be implied by laws as conditions or warranties of purchase of an Automatic Technology Australia Pty Ltd Garage Door Opener. Automatic Technology Australia Pty Ltd hereby further expressly excludes all or any liability for any injury, damage, cost, expense or claim whatsoever suffered by any person as a result whether directly or indirectly from failure to install the Automatic Technology Australia Pty Ltd Garage Door Opener in accordance with these installation instructions.





1. Important Safety Instructions

The safety alert symbols below indicate a personal safety or property damage instruction exists. READ THESE INSTRUCTIONS CAREFULLY. This NeoSlider™ Sliding Gate Opener is designed and tested to offer safe service provided it is installed and operated in strict accordance with the following safety rules. Failure to comply with the following instructions may result in death, serious personal injury or property damage.



WARNING!

- The gate may operate unexpectedly, therefore do not allow anything to stay in the path of the gate.
- Do not disengage the gate opener to manual operation with children/persons or any objects including motor vehicles within the gateway.
- Remove or disengage all gate locks and mechanisms prior to installation of the opener.
- Make sure the gate is fully open before driving into or out of the driveway.
- When using auto close mode, a **Photo Electric beam** must be fitted correctly and tested for operation at regular intervals. **Extreme caution** is recommended when using auto close mode. **All safety rules** must be followed.



ELECTROCUTION!

- Do not immerse in or spray the NeoSlider with water .
- **Disconnect the power cord** from mains power before making any repairs or removing covers. Only **experienced** service personnel should remove covers from the gate opener.
- If the power supply cord is damaged, it **must** be replaced by an Automatic Technology service agent or suitably qualified person.
- Connect the gate opener to a properly **earthed** general purpose 240V mains power outlet installed by a qualified electrical contractor.



CAUTION:

Entrapment from operating gate

- **DO NOT** operate the gate opener unless the gate is in full view and free from objects such as cars and children/people. Make sure that the gate has finished moving before entering or leaving the driveway.
- Do not allow children to play with gate controls or transmitters.
- In order for the NeoSlider™ to **sense** an object obstructing the gateway, some **force** must be exerted on the object. As a result the object, gate and/or person may suffer **damage** or **injury**.
- Regularly check to make sure that the **Safety Obstruction Force** is working correctly, and is **tested** and set as per **Section 12 of this manual**. Failure to follow these instructions could result in **serious personal injury** and/or property damage. This test must be repeated at regular intervals and the necessary adjustments made as required.
- If using a key switch, keypad or any device that can operate the gate opener, make sure it is in a location where the gateway is visible, but out of the reach of children at a height of at least 1.5m.
- For **ADDITIONAL SAFETY** protection we **STRONGLY** recommend the fitting of a Photo Electric (Safety) Beam. In most countries Safety Beams are mandatory on all gates fitted with automatic openers.
- Ensure the gate(s) is in good working order . Faulty gates must be repaired by a qualified technician prior to NeoSlider™ installation.
- Make sure that the gate is fully closed before leaving the driveway.
- Keep hands and loose clothing clear of gate at all times
- Keep clear of gate during operation as severe lacerations can occur on sharp edges of gate.

Installation

Security

Entanglement in or laceration from moving gate



2. Control Board Layout

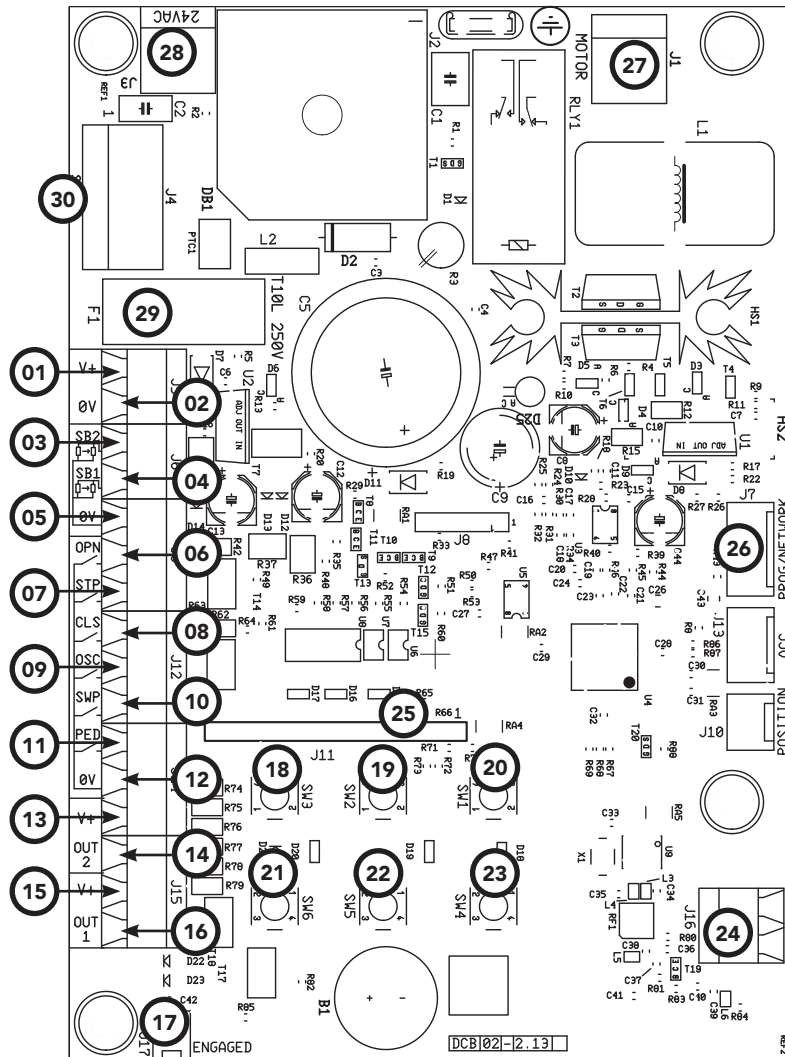

Fig 2.1

- | | | |
|---|---|--|
| 01 V+ | 11 PED N/O input terminal | 21 Console Exit button |
| 02 0V | 12 0V | 22 Console Down/Close button |
| 03 SB2 (Safety Beam (2), two, three wire or wireless) | 13 V+ | 23 Console SET button |
| 04 SB1 (Safety Beam(1), two, three wire or wireless) | 14 OUT 2 (optional relay module coil drive) | 24 Antenna connector |
| 05 0V | 15 V+ | 25 Console display |
| 06 OPN Programmable N/O or N/C input terminal | 16 OUT 1 N/C relay contact | 26 PG3 programmer / network connector |
| 07 STP Programmable N/O or N/C input terminal | 17 Engage sensor microswitch input | 27 Motor connector |
| 08 CLS N/O input terminal | 18 Console Previous button | 28 24VAC input connector |
| 09 OSC N/O input terminal | 19 Console Up/Open button | 29 10 AMP slow blow fuse |
| 10 SWP N/O input terminal | 20 Console Next button | 30 Standby battery charger/solar connector |

3. Set Up Requirements

3.1 Kit Contents

ITEM	DESCRIPTION	QTY
1	DRIVE UNIT NES-500 / NES-800	1
2	TRIO-CODE 4B PTX-5V2 TRANSMITTER	2
3	METAL BASE PLATE	1
4	NUTS, BOLTS AND WASHERS	4
5	ACTUATOR W/ 2 SCREWS	2
6	ANTENNA	1



IMPORTANT WARNING!

A qualified electrician must perform the installation where 240V AC power is used.



CAUTION: Cables which have a green/yellow coloured insulation are for earthing purposes only. Never use these cables for any other purpose.

3.2 Choosing your Set up

The NeoSlider™ can be set up in various ways and therefore may require additional items. Common Set ups are as follows;

Set Up	Items Required
Automated Set Up	Drive Unit and transmitter
Automated Set Up with Safety Beams	Drive Unit, transmitter and safety beams (optional)

3.3 Initial Checking

Before commencing installation of the NeoSlider™, check the following:

- The gate moves freely and easily by hand for the full opening and closing travel.
- The mounting point must be solidly constructed, e.g concrete, brick or steel, and must be capable of withstanding the full force applied to the gate.
- Select a suitable location for mounting the drive unit. This position is usually established by fully opening the gate and mounting the drive unit within a suitable distance of the gate edge.
- A weather-proof 240v 10 amp power outlet must be located within one (1) metre of the NeoSlider™ mounting point.
- If Safety Beams are to be installed, provision for underground cabling should be made from one side of the gateway to the other.

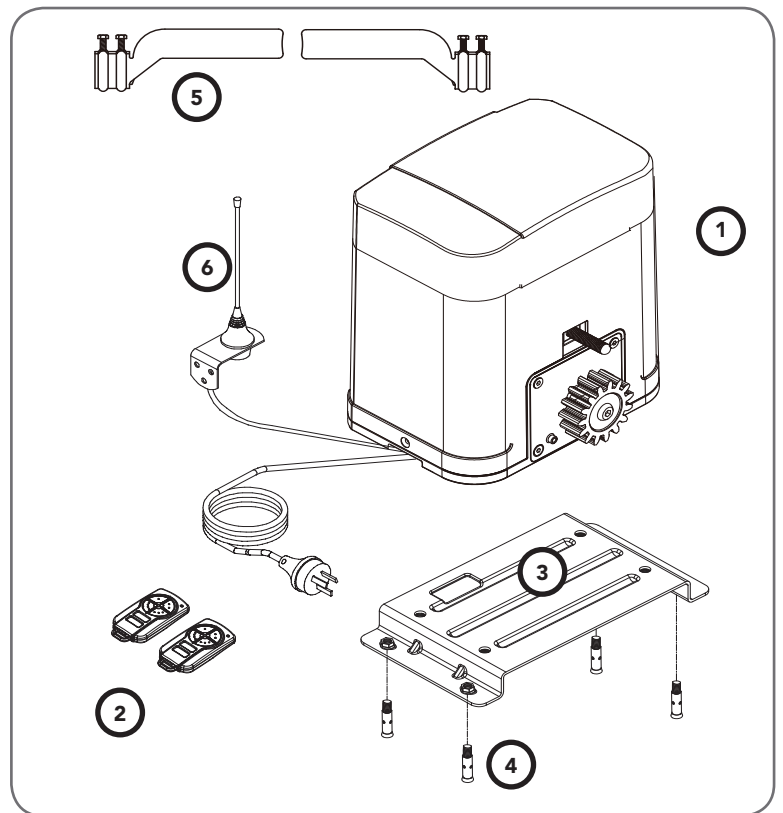

Fig 3.1

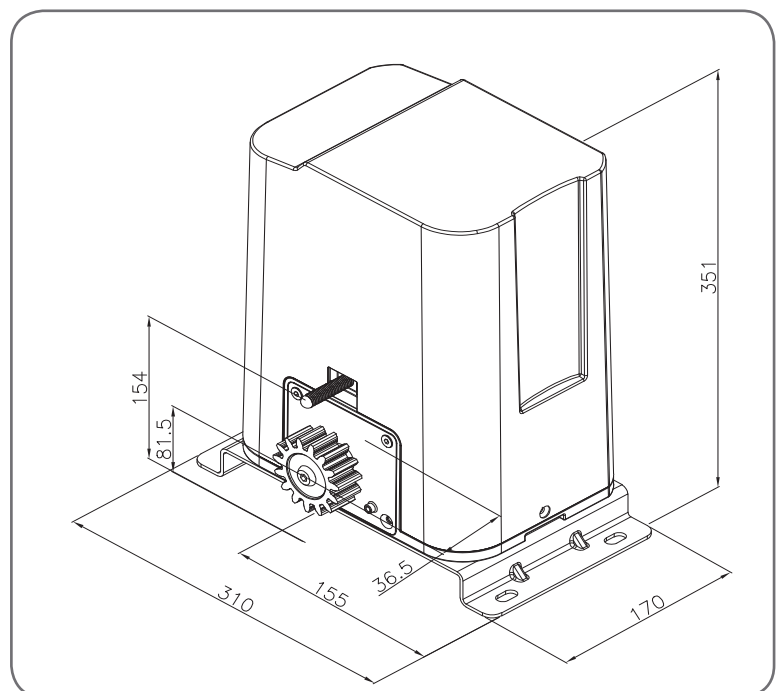

Fig 3.2



4. Drive Unit Installation

The Automatic Technology NeoSlider™ sliding gate opener is designed to operate most residential sliding gates. The gates must be in good working condition and should operate freely by hand. (Refer to 3.1 Initial Checking)

4.1 Mounting the Drive Unit

The NeoSlider™ mounting holes are slotted for fine adjustment of pinion gear and gate rack alignment. Follow the procedure below to ensure final adjustments can be made later.

- Prior to mounting the NeoSlider™, determine the distance from the gate to the outer edge of the rack (i.e. the rack width) and to the datum line (see Fig. 4.1 and Fig. 5.1). If using an Automatic Technology plastic rack, the width is 40mm. If using a different brand of rack, please ensure it is Module 4 and then confirm the width, as this will vary.
- Mark a line parallel to the face of the gate for the mounting holes. The distance from the gate is determined by the formula $(38\text{mm} + \text{Rack Width})$. Therefore, if using an Automatic Technology rack, the distance is 78mm. Otherwise, if using a non-Automatic Technology rack, add your rack width (and spacers if required) to the 38mm (see Fig. 4.1).
- Place the metal base plate (3) and Drive unit (1) in position. If satisfied with the position, remove the Drive Unit and metal base plate (Fig. 4.2).
- Mark the position of the four holes in the metal base plate (3). Drill the four holes.
- Hammer the dynabolts (4) into position, place metal base plate and fix with the four washers, spring washers and nuts (4).
- Put Drive unit (1) onto metal base plate and affix with bolts and washers provided. Remember when tightening the bolts to allow fine adjustment of the NeoSlider™ later on.

4.2 Installing antenna

Mount the antenna (6) at or above the height of the gate or fence (whichever is higher) for optimal reception.

Do not cut the coaxial cable.

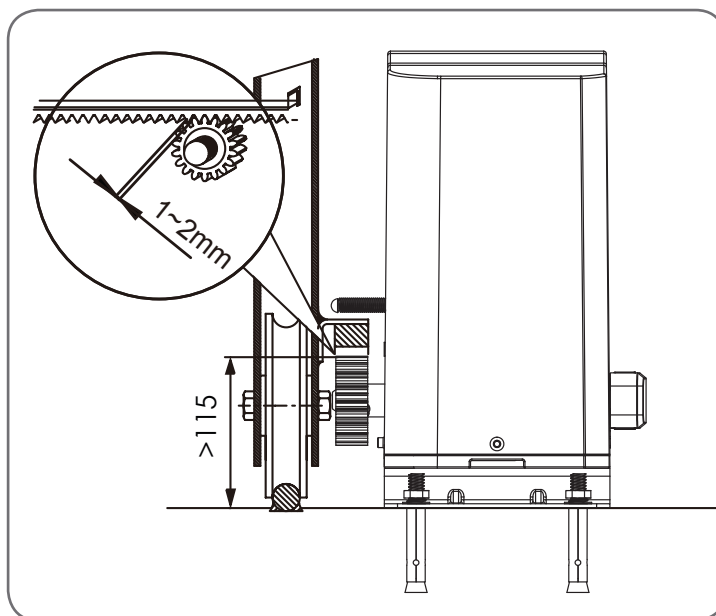

Fig 4.1

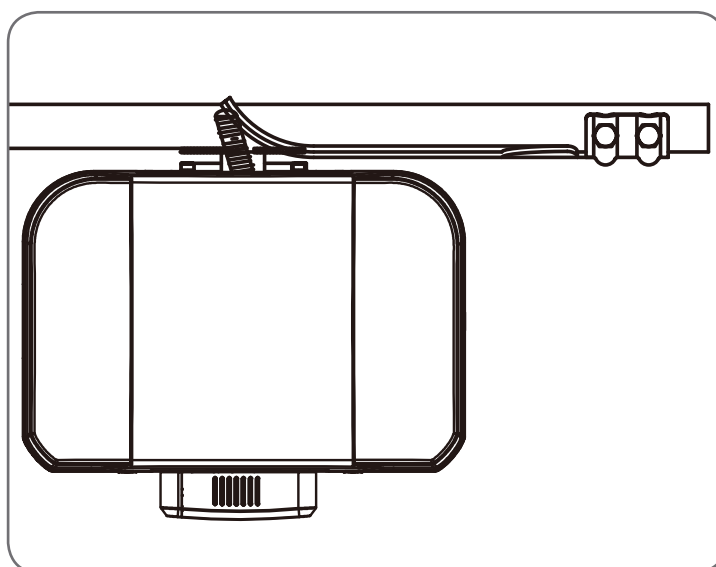

Fig 4.2

5. Rack & Limit Actuator Installation

5.1 Mounting rack to gate

A strong base on the gate is required for mounting the rack.

- Manually open the gate and place a rack section to mesh with the pinion gear on the Drive Unit. Mark the top of the rack. Move the gate and mark the rack for the entire length of the gate (**Fig. 5.1**).
- Position the top edge of the rack on this line and mark the centres of the rack's mounting slots. The first section of rack should start 20mm from the edge of the gate.
- Drill and tap for 6mm ($\frac{1}{4}$ ") screws.
- Once the first section of the rack is mounted, check that it meshes with the NeoSlider™ pinion gear.
- When joining subsequent sections of rack, check the mesh by placing a spare section upside down (teeth facing upwards) and putting it into mesh with the racks being joined (**Fig. 5.2**).
- Tighten the racks. This will ensure that the NeoSlider™ pinion can run along the racks without obstruction.

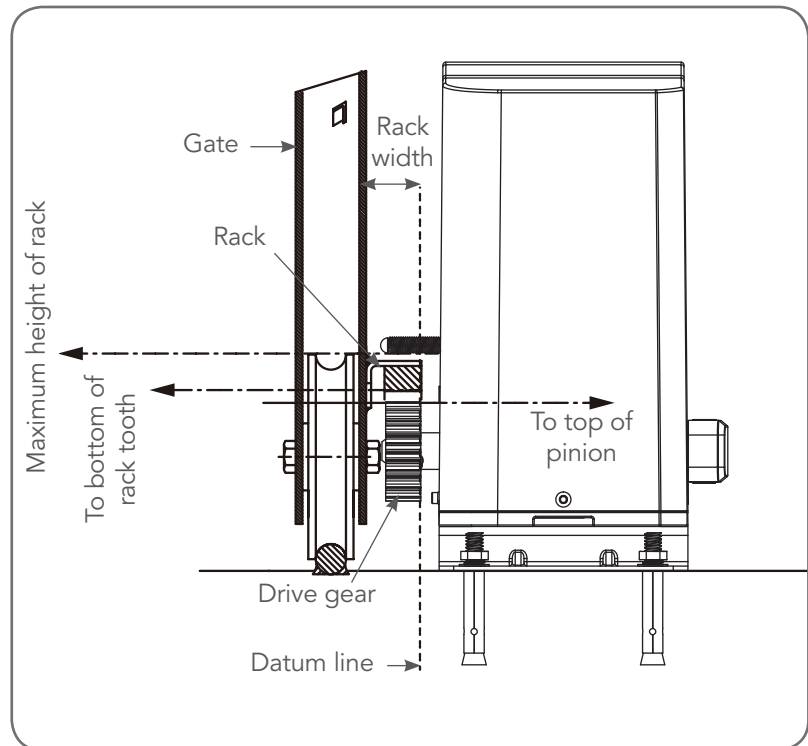

Fig 5.1

5.2 Fixing limit actuator to rack

- Manually open the gate to the open position and mark this on the gate rack under the actuating arm.
- Manually open the gate to the open position and mark this on the gate rack under the actuating arm.
- Place the start of the limit actuator (5) at marked position and move it 5 to 10mm towards the centre of the gate. Screw the limit actuator to the rack (**Fig. 5.3**). Repeat for the close position.
- Re-check limit positions by manually opening and closing the gate, checking to see that the limit is activated at the desired open and close position. If necessary, make adjustments by sliding the actuator in the required direction.

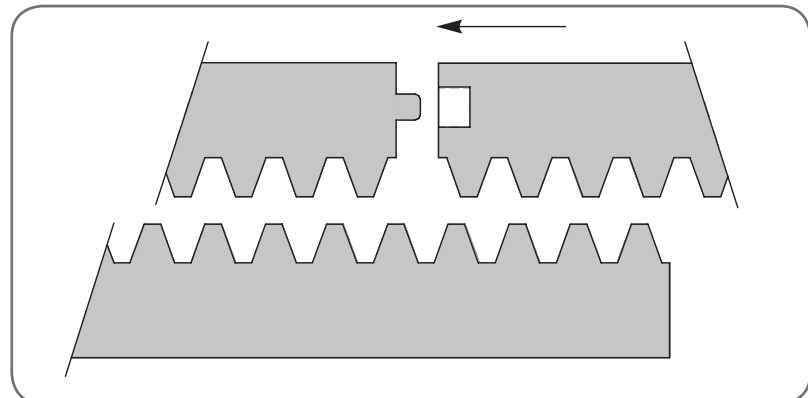

Fig 5.2

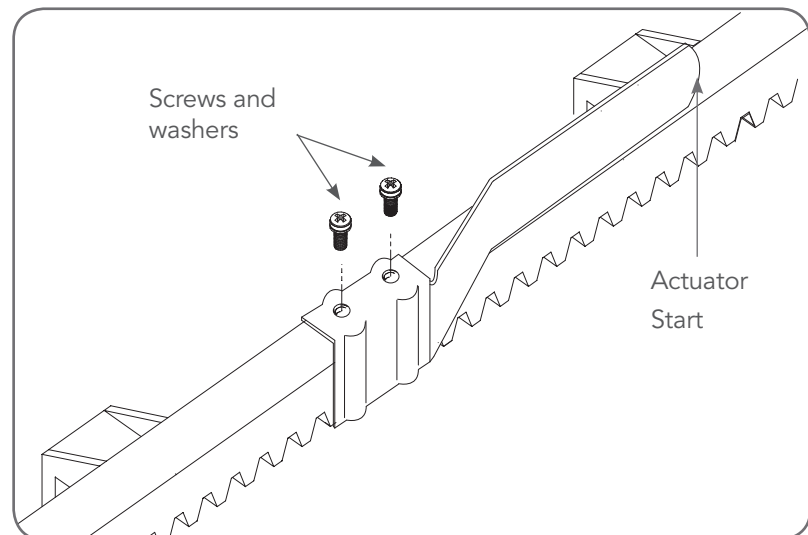

Fig 5.3

6. Programming The NeoSlider™

6.1 Common Programs

The two most common programs are;

Program	Menu's required	Function	Section
Automated Set Up	Menu 10.1	Setting the Limits	8.1
		Safety Obstruction Force	9.1 and 9.2
	Menu 1	Coding the Transmitter	10.1
Automated Set Up with Safety Beams	Menu 10.1	Setting the Limits	8.1
		Safety Obstruction Force	9.1 and 9.2
	Menu 1	Coding the Transmitter	10.1
	Menu 3	Auto Close Times	13.2, 13.3 and 13.4

Fig 6.1

NOTE: Fitting Safety Beams enables the Auto-Close feature to become active.



CAUTION: Before plugging the gate control system in, check the power cord for damage and ensure it cannot become entangled in any moving parts

6.2 Powering up the NeoSlider™

- After checking the initial wiring, apply power to the NeoSlider™. The controller will go through a startup sequence displaying the STARTUP SCREEN which indicates the controller type and firmware version (Fig. 6.2). After a short delay the MAIN SCREEN will be displayed.
- If this is the first time the NeoSlider™ has been used, the MAIN SCREEN should indicate that the limits are not set. If the display shows that some input is active then rectify the situation before proceeding. If a default setting is to be changed it should be done now before setting the travel limits.

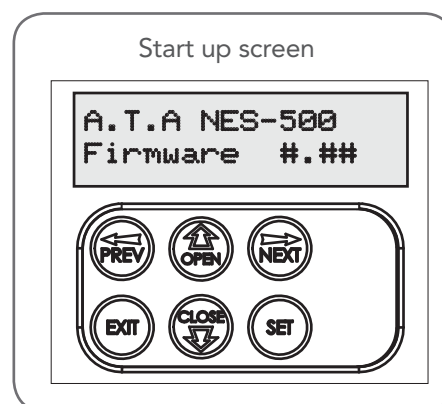

Fig 6.2

7. Safety Beams

7.1 Installation of Safety Beams to the NeoSlider™

- Follow the Installation Manual provided with the Safety Beam to correctly install the Safety Beam.
- By default the NeoSlider™ will take two wire safety beams.
- Ensure you program the NeoSlider™ to identify what type of Safety Beam or combination of Safety Beams you have installed.
 - Press NEXT to Navigate to Menu 7
 - Press SET to display Menu 7.1 (for SB1).
 - Ensure the Safety Beam type is set to two wires.
 - Press SET to accept the selection.
 - Repeat the same process for Menu 7.2 (SB2) if installed.

NOTE: Wireless Safety Beam functionality is equivalent to 2 WIRE Safety Beams

NOTE: The Power control for one or both three wire beams is controlled via OUT 1 or OUT 2. To use the OUT 1, connect black wire from SB to OUT 1. To enable power control from OUT 1, go to Menu 7.13 and change OUT1 mode to 3 wire SB 0V.

NOTE: In the case that OUT 1 is used for some other function, OUT 2 can be used to control 3 wire beams power. Connect the black wire from SB to OUT 2, then change the OUT 2 mode in Menu 7.14 to 3 wire SB 0V.



WARNING: When using Safety Beams, the gateway must be clear of all obstructions and persons at all times. The location of the beams and manner in which it is installed might not give safety protection at all times. Check to make sure that the height of the beam and type used give maximum protection possible



WARNING: Tampering with Safety Beams could result in serious personal injury and/or property damage and will void the warranty.

7.2 Safety Beam Failure Emergency Close (SBFEC)

When the user finds that they are unable to move the gate and suspect that it is due to a faulty SAFETY BEAM they can attempt to enter Safety Beam Failure Emergency Close mode by pressing and holding a pre-coded button on the remote control or OPEN/CLOSE button on the console for more than five seconds. the gate will start closing. See Appendix C Menu 7.16.

8. Setting Limits

The NeoSlider™ has the alternate ability to set travel limits using a TrioCode™128 transmitter, allowing free movement around the gate to better assess the desired limit positions. In order to use a transmitter, it must first have at least one of its buttons coded to the gate controller. The function assigned to the transmitter's buttons is of no concern here as the buttons are temporarily assigned to OPEN, CLOSE and SET (**Fig. 8.1**).

8.1 Setting Travel Limits

Navigating to "code transmitter" menu

- a. Press NEXT to navigate to Menu 1.
- b. Press SET to enter the code set procedure.

Storing Transmitter Code

- c. Controller will prompt to press one of the transmitter's Button.
- d. Press the transmitter button you wish to use to operate the gate opener (e.g. button 1) .
- e. Press the same transmitter button again as prompted by display.
- f. Press the SET button to store the transmitter.

Navigating To "Set Gate Travel Menu"

- a. Press PREV to navigate to Menu 10.
- b. Press SET to display MENU 10.1.
- c. Press SET two times to enter the limit setting procedure. Follow LCD prompts.

8.2 Setting the left/right installation side settings

- a. Select left or right installation side by pressing open button for the correct side.
- b. Press SET to confirm.

8.3 Setting close travel limit

- a. Press and hold Button 4 on the transmitter to close the gate
 - i. If the gate is closed too far, press Button 1 to "inch" the gate towards open.
 - ii. When happy with the close limit position, press Button 2 to store this in the memory.

NOTE: Limit will not be accepted unless the gate is driven in the close direction.

8.4 Setting open travel limit

- a. Press Button 1 to open the gate.
- b. If the gate is opened too far, press Button 4 to "inch" the gate towards close
- c. When happy with the open limit position, press Button 2 on the transmitter to store into memory..

NOTE: Limit will not be accepted unless the gate is driven in the open direction.

 **WARNING: The gate will automatically close and open once next step is performed. Ensure that no persons or objects are in the gates path**

- d. The gate will now automatically close and open to calculate the safety obstruction settings.

8.5 Automatic limit adjustment and load profile

After a brief pause, the controller will automatically close and open the gate several times. This adjusts the speed at which the limits are approached and helps to learn the normal load profile of the gate. When the setup is complete, the MAIN SCREEN will be displayed with the gate shown to be OPEN. The Gate can now be used.

NOTE: Do not press transmitter during limit adjustment process.

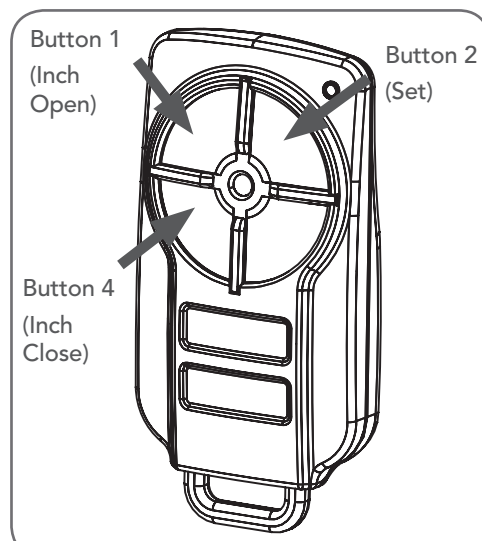

Fig 8.1

IMPORTANT NOTE:

Only TrioCode™128 Technology Transmitters are compatible with this product.

8.6 Pedestrian access position

After completing the above procedure, the Pedestrian access position is automatically set to a position which is five (5) seconds from the fully closed position of the gate. The position can be manually set by following the SETTING PEDESTRIAN POSITION procedure (See Section 12).

8.7 Errors during setting of travel limit

During the above procedure, many error checks are performed. If an error is detected, a message will be displayed indicating the error.

8.8 Recalculate Force Margins

- a. Reprofiling is a simplified way of re-learning the travel characteristic of a previously setup Limit Switch travel installation. Re-profiling can be used when the travel characteristics of the gate change due to mechanical adjustments etc.
- b. To initiate a re-profile simply locate "MENU 10.2 Reprofile Travel"

 **WARNING: The gate(s) will automatically close and open. Ensure that no persons or objects are in the gates path.**

- c. Press SET then follow the prompts. The gate will start to move and re-calculate force margins. The gate can move between the open and close limit positions up to two (2) times (depending on the position of the gate and the power up condition).
- d. A single beep will be heard once the process is complete and setup complete message will be displayed

9. Safety Obstruction Force Test



WARNING! Take care when testing or adjusting the Safety Obstruction Force. Excessive force may cause SERIOUS PERSONAL INJURY and/or PROPERTY DAMAGE.

9.1 Testing Close Cycle

- Press the OPEN button to open the gate.
- Place a piece of timber approximately 40mm wide on the ground directly next to the closing pylon / fence (**Fig. 9.1**).
- Press the CLOSE button to close the gate. The gate should strike the object and start to re-open.

9.2 Testing Open Cycle

- Press the CLOSE button to close the gate.
- Press the OPEN button to open the gate. When the gate reaches the half open point, grab the side rail of the gate firmly and the gate should stop.
- If the gate does not reverse readily when closing, or stop when opening, the force may be excessive and need adjusting.

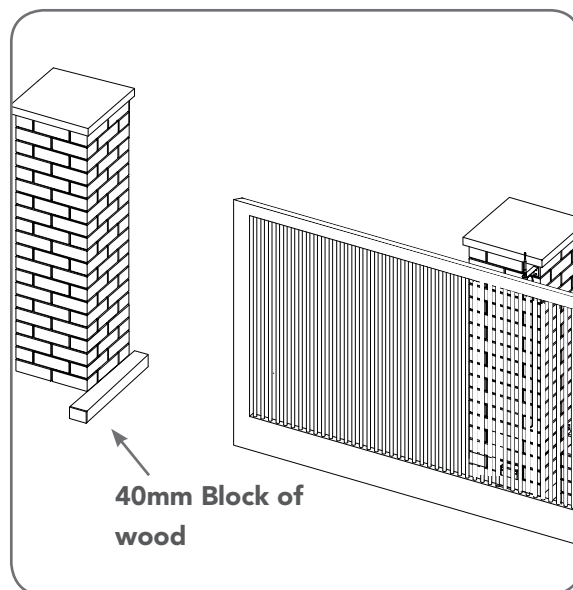

Fig 9.1



WARNING! If the gate fails these tests, put the opener into manual mode, only operate the gate by hand and call for service.

Safety Obstruction Force

The Safety Obstruction Force is calculated automatically during setup. Adjusting this is normally only necessitated by environmental conditions such as windy or dusty areas, and areas with extreme temperature changes.

9.3 Force Pressure For Close and Open Cycle.

Navigating To "Current Trips"

- Press NEXT or PREV to navigate to Menu 2 Current Trips.
- Press SET (**Fig.9.2**)
- MENU 2.1: CLOSE Margin is displayed (**Fig. 9.3**).
- Press UP arrow to increase or DOWN arrow to decrease the value.
- Press SET to save the new value.
- Test the force again as per "Safety Obstruction Force Test" in Section 9.1.

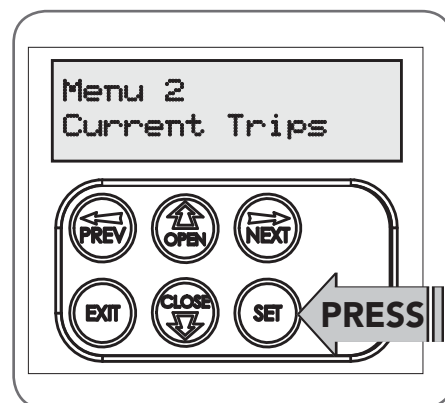

Fig 9.2

9.4 Reprofile Travel

- Reprofiling is a simplified way of re-learning the travel characteristic of a previously setup Limit Switch travel installation. Re-profiling can be used when the travel characteristics of the gate changes due to mechanical adjustments etc. To initiate a re-profile, simply locate "MENU 10.2 Reprofile Travel", press SET and follow the prompts. The gate will start to move and re-calculate force margins. The gate can move between the open and close limit positions up to two (2) times (depending on the position of the gate and the power up condition).
- A single beep will be heard once the process is complete.
- Test the force again as per "Safety Obstruction Force Test" (Section 9.1 and 9.2).

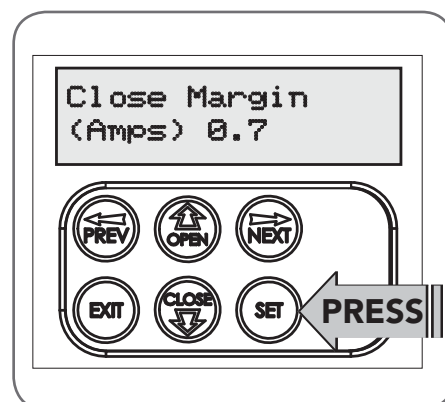

Fig 9.3

10. Coding Transmitter

The NeoSlider™ can store up to thirty (30) transmitters in its memory. Each transmitter can be allocated an alpha-numeric ID label up to eleven (11) characters in length and each button can be assigned to one of several control functions. The settings for a transmitter are represented in **Fig. 10.1**. It shows the transmitter's store number, ID label or serial number and the functions assigned to each of the four buttons. To toggle between ID/SN display, press UP/DOWN with the cursor on the ID/SN indicator. The procedures below code, delete, replace, edit and copy transmitter records.

10.1 Coding Transmitter Button

Navigating To Menu 1 "Code Transmitter"

- Press NEXT to navigate to Menu 1).
- Press SET to enter the code set procedure.

Storing Transmitter Code

- The controller will prompt to press one of the transmitter's buttons.
- Press one of the four (4) buttons on the transmitter for two (2) seconds, pause for two (2) seconds, then press the same button again for two (2) seconds (**Fig. 10.2**).

10.2 Selecting Function Of The Button

The controller will now show the transmitter's record, with a cursor on the field for the button being coded (**Fig. 10.3**). Use OPEN/CLOSE to select the function for the button.

Available functions:

VAC (Vacation Mode)	LGT (Courtesy Light)
STP (Stop)	OPN (Open)
CLS (Close)	SWP (Swipe)
PED (Pedestrian access)	OSC (Open/Stop/Close)
OFF (No action)	

Press SET to save the settings or STOP to abort without saving.

10.3 Returning To Main Screen

Press EXIT to return to the MAIN SCREEN and test the transmitter. **NOTE:** To edit the other settings, refer to transmitter edit procedure in Appendix F.

If a transmitter is already coded into the opener, additional transmitters can be coded without being in direct contact with the opener's wall console unit.

10.4 Selecting The Function To Be Coded

- Using the existing transmitter, operate the gate with the transmitter button which has the function to be coded (e.g. Button 1 has been coded with the OSC function assigned).
- Use a small pin / pen to press and hold through the Coding Hole of the existing transmitter for 2 seconds (**Fig. 10.4**).
- Within 10 seconds, press the button on the new transmitter you wish to code for 2 seconds and release (**Fig. 10.5**).
- Press the same button again for 2 seconds and release.
- Test Operation. The new transmitter button should now function as the existing transmitter.

NOTE: To Manage your Transmitters, refer to Transmitter Management in Appendix G.

IMPORTANT NOTE:

Only TrioCode™128 Technology Transmitters are compatible with this product.

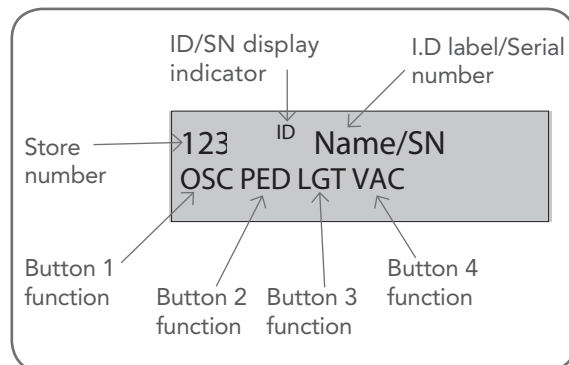

Fig 10.1

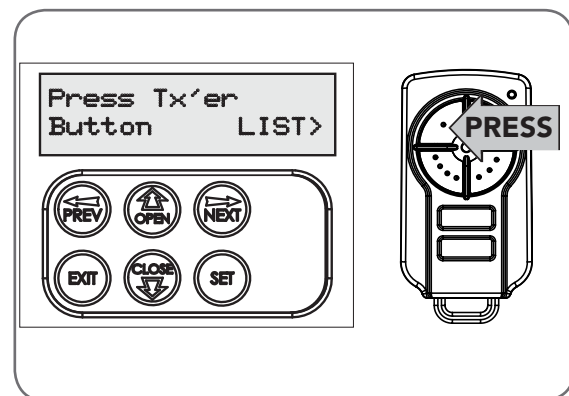

Fig 10.2

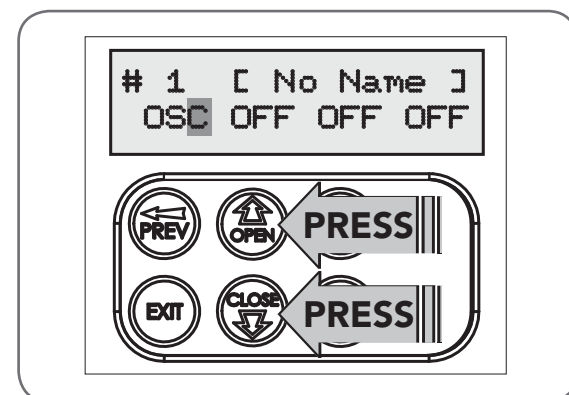

Fig 10.3

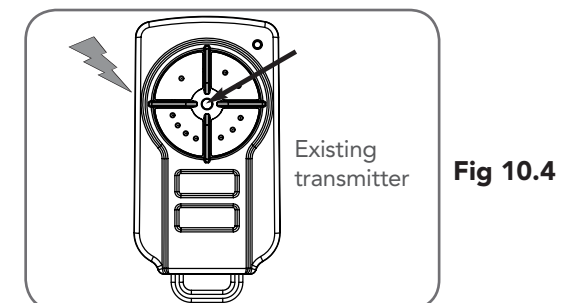

Fig 10.4

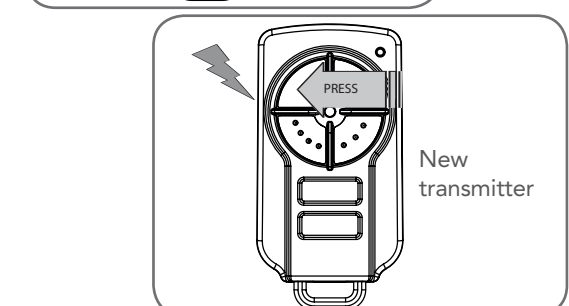

Fig 10.5

11. Emergency Release

11.1 Your gate CAN NOT be used by the opener when:

- There is a power failure.

11.2 Your gate CAN be used when:

- There is an emergency, by disengaging the opener.
- There is a power failure, by disengaging the opener.

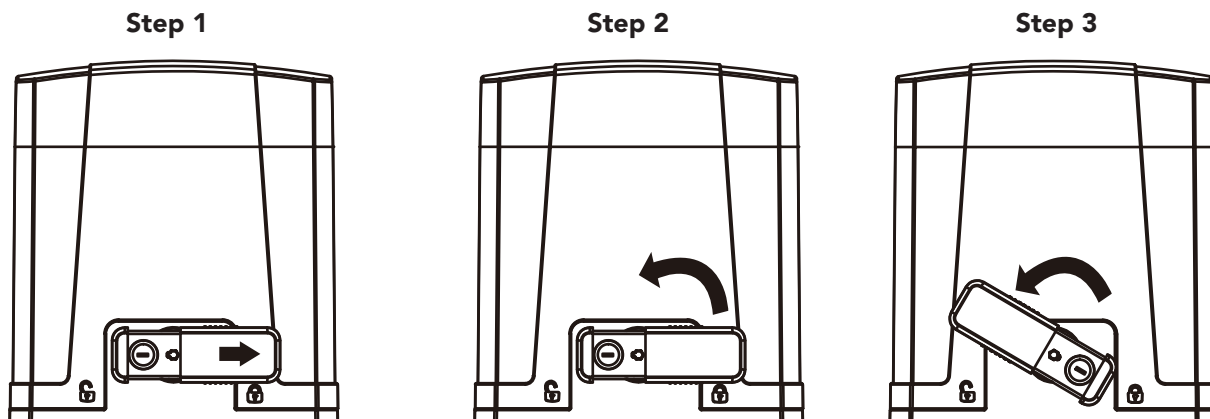

Fig 11.1

11.3 To Disengage the Opener:

- Push the lid of release chamber and move to the right.
- Insert the key and turn counterclockwise to unlock the device.
- Turn the lever counter-clockwise to release the motor.

11.4 To Re-Engage the Opener:

- Turn the lever clockwise to engage the motor.
- Turn the key clockwise to lock the device.
- Move the release chamber to the left to close.

12. Setting Pedestrian Position

NeoSlider™ can be instructed, via its pedestrian control feature, to partly open and provide pedestrian access but prevent vehicle access.

NOTE: Before setting the pedestrian access position the gate must be in the fully closed position. As with the Setting Travel Limit procedure, a transmitter can be used to complete the pedestrian position setting procedure.

NOTE: The pedestrian default position is set at five (5) seconds from fully closed position and can be changed as follows:.

12.1 Setting pedestrian position

Navigating to "Menu 10.3 Set Pedestrian"

- Press PREV to navigate to Menu 10.
- Press SET - MENU 10.1 is displayed.
- Press NEXT to go to MENU 10.3.
- Press SET to enter Set Pedestrian procedure.

To Set pedestrian position

- Press OPEN to change the pedestrian access position time (**Fig. 14.1**).
- Press SET to record new time.
- Press transmitter coded for pedestrian function to test.

12.2 Pedestrian Position Set

The controller will return to the MAIN SCREEN with the gate status shown as being in pedestrian access mode (**Fig. 14.2**).

12.3 Error Displays

During the above procedure many error checks are performed. If an error is detected, a message will be displayed indicating the error.

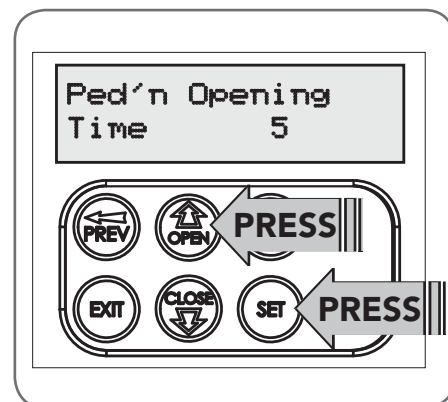

Fig 12.1

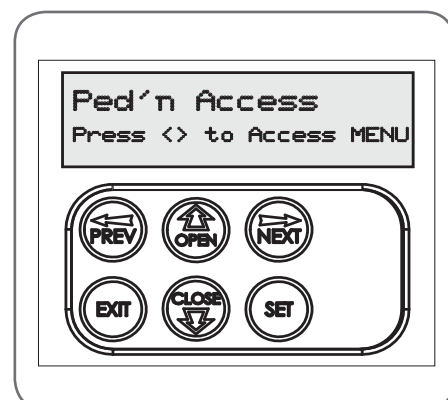

Fig 12.2

13. Auto-Close Mode



WARNING! The Auto-Close function is not available unless Safety Beam is installed.

13.1 Setting Up Standard Auto-Close

Menu 3. Auto-Close Times

Auto-Close mode is a function that automatically closes the gate a preset time after the Safety Beam recognises that a vehicle has left the gateway. The Auto-Close timer only starts after the Safety Beam path is broken and the Auto-Close timer has been set. If the Safety Beam path is not broken, the gate will remain open until the path is broken. If the opener incurs a physical obstruction (i.e. not from the Safety Beam) while closing, the gate will re-open and not Auto-Close until the Safety Beam path is broken again.

Menu 3.1 Auto-Close

This mode is selected by entering a non-zero time for the STD Auto-Close parameter. When selected, the gate will Auto-Close after being fully opened (except when the gate has reversed to the open position after a motor obstruction or overload unless A/C after open and/or close Obstruction are selected). Countdown is suspended by: S.B., OPN or SWP input being active. The countdown is aborted if the STP input is activated. If the gate is already open and the OPN or the SWP input is activated, then the countdown will start.

13.2 Safety Beam Triggered Auto Close

Menu 3.2 (SB AC Trig)

This mode is selected by entering a non-zero time for the "Safety Beam Auto-Close" parameter. This mode is used to Auto-Close the gate but only after an object has passed through the gateway and has triggered the Safety Beam input. Any Safety Beam or combination of Safety Beams can be configured to activate Safety Beam Auto-Close mode and combinations are:

One Beam only

- i. Safety Beam 1
- ii. Safety Beam 2

Either Beam

- i. Safety Beam 1 or Safety Beam 2

Combination

- ii. Safety Beam 1 and Safety Beam 2
- iii. Safety Beam 2 then Safety Beam 1

NOTE: The swipe input can be used to clear the Safety Beam triggered status so that the Safety Beam input must be activated again before the countdown will start. As with the other Safety Beam modes, the STP input will abort countdown and the OPN and SWP inputs will restart the countdown if the gate is OPEN.

13.3 Pedestrian Auto-Close

Menu 3.3 Safety Beam Auto-Close

This mode is selected by entering a non-zero time for the "Safety Beam Auto-Close" parameter. This mode is used to Auto-Close the gate but only after an object has passed through the gateway and has triggered the Safety Beam input

Menu 3.4 Pedestrian Auto-Close

This mode is selected by entering a non-zero time for the "Ped'n A/C" parameter. When selected, the gate will Auto-Close after being opened for pedestrian access unless it was following a reverse from an obstruction.

Menu 3.5 (Safety Beam) Pedestrian Triggered Auto-Close

This mode is selected by entering a non-zero time for the "Safety Beam Pedestrian Auto-Close" parameter. Any Safety Beam or combination of Safety Beams can be configured to activate Safety Beam Auto-Close mode and combinations are:

One Beam only

- iv. Safety Beam 1
- v. Safety Beam 2

Either Beam

- i. Safety Beam 1 or Safety Beam 2

Combination

- ii. Safety Beam 1 and Safety Beam 2
- iii. Safety Beam 2 then Safety Beam 1

Menu 3.6 (Safety Beam) Pedestrian Auto-Close

This mode is selected by entering a non-zero time for the "Ped'n A/C" parameter. When selected, the gate will Auto-Close after being opened for pedestrian access but only after an object has passed through the gateway and has triggered the Safety Beam input.

13.4 Auto-Close After Obstruction

Two parameters are provided to enable the Auto-Close feature to be activated after obstructions and power up. Normally the Auto-Close feature is not enabled after obstructions for safety reasons. Safety Beams must be used for these features to be activated.

Menu 3.7

This mode enables the Auto-Close feature to be activated when a close obstruction occurs (requires Safety Beams).

Menu 3.8

This mode enables the Auto-Close feature to be activated when an open obstruction occurs.

Menu 3.9

This mode enables Auto-Close feature after power up.



14. Accessories Installation

Wiring Output1 And Output2

Outputs 1 and 2 are used to control a lock, Light or Safety Beam power. Which output is to control which function and the way it is controlled is programmable. If using these outputs make sure that the functions are configured for correct operation prior to setting the travel limits. OUTPUT1 or OUTPUT2 is used to activate an optional external relay module (RO-1) which in turn is used to switch the load.

14.1 Fitting Solenoid Or Magnetic Locks

Install the lock mechanism on the gate as per the manufacturers instructions. See **Fig. 14.1** for the wiring diagram.

Menu 4. Lock Times

Lock output can be programmed for both hold and pulse mode. The operation of the lock can be programmed to activate prior to the gate and behave differently on open cycles to that on close cycles.

- Press NEXT or PREV on the wall control unit to navigate to Menu 4 Lock Times.
- Press SET to select the sub menu.
- Press NEXT or PREV to navigate through the sub menu.
- Press OPEN to increase or CLOSE to decrease the time.
- Press SET to save the new time.
- Press the EXIT button two times to exit and test the locks operation.

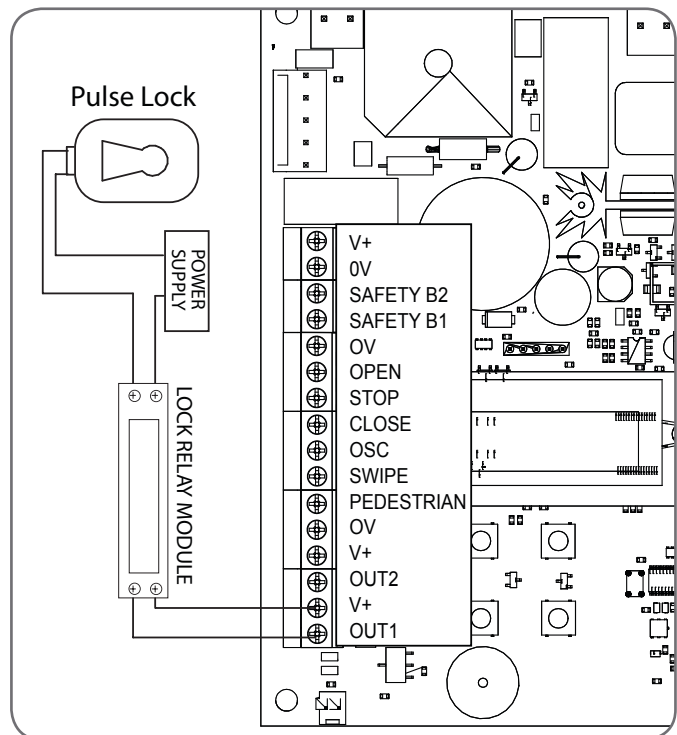

Fig 16.1

14.2 Fitting Courtesy Lights

An AC or DC courtesy light can be activated via an output on the gate opener control board. Connect the light as per the diagram. (**Fig. 14.2**)



WARNING: A qualified electrician must perform the installation where 240V AC power is used.

Menu 5. Light Times

- Press NEXT or PREV on the wall control unit to navigate to Menu 5 Light/Lock Times.
- Press SET to select the sub menu.
- Press NEXT or PREV to navigate through the sub menu.
- Press OPEN to increase or CLOSE to decrease the time.
- Press SET to save the new time.
- Press the EXIT button two times to exit.
- Test the light operation.

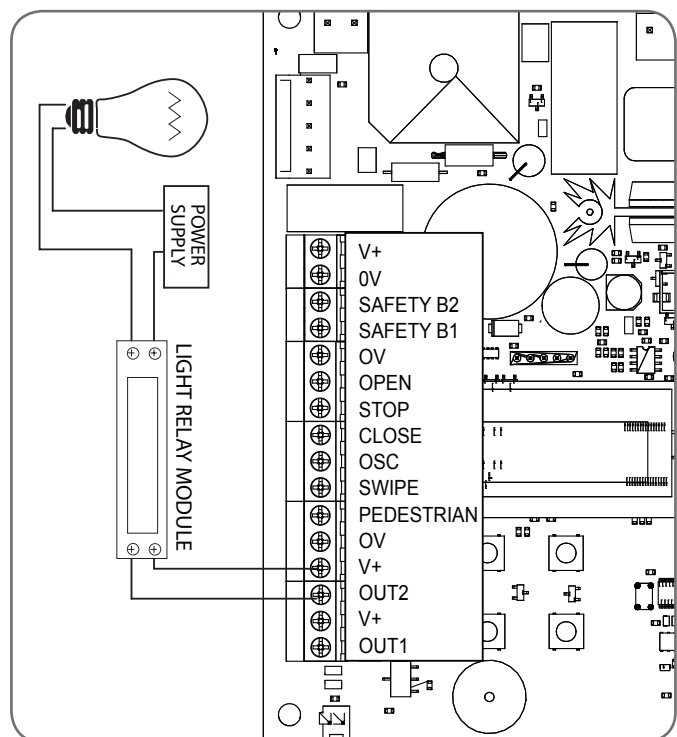

Fig 16.2

15. Battery Replacement

15.1 Removing the Battery From the Transmitter

(Battery Type: 3V Lithium Battery CR2032).

Use a non-metallic object (e.g. pen) to remove the battery. (Fig. 15.1). To test the battery is working, press and hold a transmitter button; (Fig. 15.2).

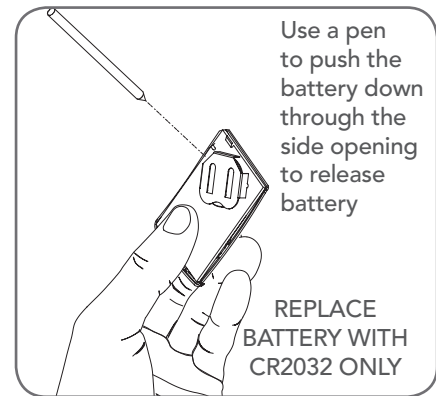

Fig 15.1

Light Status	Battery Status
Solid	OK
Flashing	Requires replacement
No light	Requires replacement

Fig 15.2

16. Battery Disposal

When batteries reach the end of their usual life in accordance with Australian Battery Recycling Initiative please follow the next simple steps for protecting the environment.

Refer to the Automatic Technology website for information on where to recycle batteries in Australia.

Recycling all batteries will have other environmental and social benefits:

- Some batteries are less toxic but hazardous for other reasons. Lithium batteries can explode or catch fire in landfill, while button cells are dangerous if swallowed by children. Recycling offers a safe and environmentally responsible solution for end of life batteries.
- Battery recycling recovers non-renewable materials such as lead, cadmium, stella, zinc, manganese, cobalt, silver, plastics and rare earth elements.
- Removal of batteries and other hazardous household products from household waste facilitates the recovery of organic materials through alternative waste technologies such as composting. Batteries and heavy metals are known contaminants in compost.
- The community supports recycling because it reduces waste to landfill and achieves environmental benefits.

 **DO NOT** throw the batteries in municipal waste. This symbol of the crossed out wheeled bin indicates that the battery should not be placed in the municipal waste. Check your local regulations for appropriate disposal of the batteries.

 **WARNING!** Prior to disposal, recycling, or collection, all battery terminals must be securely insulated with a non conductive material to prevent any two batteries from short circuiting and generating heat during storage or transport. Battery terminals may be insulated with electrical tape; or batteries may be individually packaged in a non conductive material (e.g., plastic bag or original packaging).

17. Specifications

Technical Specifications	NES-500	NES-800
Input Voltage: ¹	230 - 240 Vac	230 - 240 Vac
Mains frequency:	50 Hz	50 Hz
Maximum Input Power:	200 W	200 W
Maximum pulling force:	280N	700N
Maximum gate opening: ²	Width: 10m Weight: Up to 500kg	10m Up to 800kg
Receiver type:	TrioCode™128	TrioCode™128
Receiver code storage capacity:	30 x 4 Button Transmitter Codes	30 x 4 Button Transmitter Codes
Transmitter frequency:	433.47, 433.92, 434.37 MHz	433.47, 433.92, 434.37 MHz
Coding type:	Hopping Code	Hopping Code
No. of code combinations:	Over 100 billion random codes	Over 100 billion random codes
Code generation:	Non-linear encryption algorithm	Non-linear encryption algorithm
Transmitter battery:	CR2032	CR2032

NOTE:

1. Measurements made at 240Vac.
2. The maximum gate size that the NeoSlider™ NES-500 can be installed on is 10m wide and 500kg and the NeoSlider™ NES-800 can be installed on is 10m wide and 800kg. The gate must be well balanced. A person should be able to move the gate manually with very little effort (15kg force max.) in case of an emergency.
3. Intermittent operations may occur in areas which experience very strong wind gusts. A strong wind puts extra pressure on the gate and tracks which may in turn trigger the safety obstruction detection system intermittently.

NOTE: Specifications are subject to change without notice.



18. Troubleshooting

Symptom	Possible cause	Remedy
Gate will not operate	Mains power not switched on.	Switch on mains power.
	Opener motor is disengaged	Check that the motor is engaged for automatic operation
	Gate is obstructed.	Remove obstruction.
	The opener is in "Vacation Mode"	Turn off "Vacation Mode"(Appendix C Menu 7.4).
Gate starts to close but automatically reverses to open position	Adverse weather conditions (wind or cold) causing gate to stiffen and become tight in the tracks.	Increase force margin setting (Section 9.4)
	Possible obstruction in the gateway triggering Safety Beams.	Remove obstruction
Gate operates from opener but not from transmitter	Transmitter code not stored in memory.	Code transmitter in to openers memory. (Section 10.1)
	Transmitter does not contain TrioCode™ 128 Technology	Check the transmitter. It should have grey buttons and the model number should display V3. Contact dealer for support if otherwise.
	Flat battery in transmitter	Replace battery (Section 15)
	Antenna behind structure (gate or fence) or not in line of sight	Ensure Antenna is in line of sight (Section 5.2)
Gate does not close with transmitter	Safety Beam not working properly.	Make sure Safety Beams are operational. and no dirt is on the lens.
Gate will not close fully.	Gate limit positions need to be reset.	Reset limits positions.
	Gate obstructed and reverses	Clear obstruction or adjust force margin (Section 9.3)
Gate will not open fully.	Gate limit positions need to be reset.	Reset limits positions. (Section 8)
	Gate obstructed.	Clear obstruction or adjust force margin (Section 9.3)
Auto-Close not working	Safety Beam not installed.	Install Safety Beam. (Section 6)
	Safety Beam or wiring faulty.	Repair Safety Beam or replace wiring.
	Safety Beam not aligned correctly.	Re-align optics.
	Safety Beam is obstructed.	Remove obstruction from path of Safety Beams.
	Gate obstructed when closing.	Remove obstruction.
	Auto-Close time not set.	Set Auto-Close times (Section 13.3).
	Auto-Close mode not set	Set Auto-Close mode. (Section 13.2)



19. Appendix

A - Console Menu Structure

OPERATIONAL BUTTONS:

1. Press PREV/NEXT buttons move to Left/Right.
2. Press OPEN/CLOSE buttons to change setting.
3. Press SET button to save changes.
4. Press EXIT to return to MENU without saving changes.

Parameter	Min	Max	Default	Step	Unit	Menu	Section
Menu 1 - Code Transmitter							
STORING TRANSMITTERS	0.0	30				1	10.1
Menu 2 - Current Trips							
M1 MARGIN Sets obstruction detection margin for M1	0.0	4.0	0.7	0.1	AMPS	2.1	9.3
SETTLE TIME disable the obstruction detection in the start of the cycle	0.1	2.0	1.0	0.1	SEC	2.2	
Menu 3 - Auto Close							
STD AUTO-CLOSE TIME Sets and enables the standard Auto-Close time	0.0	300.0	0.0	1.0	Sec	3.1	15.1
SAFETY BEAM AUTO-CLOSE TIME Sets and enables the SB triggered Auto-Close time	0.0	60.0	0.0	1.0	Sec	3.3	15.2
PEDESTRIAN AUTO-CLOSE TIME Sets and enables the Pedestrian Auto-Close time	0.0	60.0	0.0	1.0	Sec	3.4	15.3
SAFETY BEAM PEDESTRIAN AUTO-CLOSE TIME Sets and enables the SB Pedestrian Auto-Close time	0.0	60.0	0.0	1.0	Sec	3.6	15.3
AUTO-CLOSE AFTER CLOSE OBSTRUCTION Enables Auto-Close feature after close obstructions	Off	On	Off			3.7	15.4
AUTO-CLOSE AFTER OPEN OBSTRUCTION Enables Auto-Close feature after open obstructions	Off	On	Off			3.8	15.4
AUTOCLOSE AFTER POWERUP Enables autoclose feature after powerup	Off	On	Off			3.9	15.4
Menu 4 - Lock Times							
OPEN LOCK TIME Set the time the lock is activated for on open cycles	0.0	Hold	0.5	0.1	Sec	4.1	16.1
CLOSE LOCK TIME Set the time the lock is activated for on close cycles	0.0	Hold	0.5	0.1	Sec	4.2	16.1
PRE-OPEN LOCK TIME Time the lock is activated for prior to opening	0.0	25.5	0.0	0.1	Sec	4.3	16.1
PRE-CLOSE LOCK TIME Time the lock is activated for prior to closing	0.0	25.5	0.0	0.1	Sec	4.4	16.1
Menu 5 - Light Times							
ON AFTER CYCLE LIGHT TIME - Time light remains on for after a cycle	0	255	60	1	Sec	5.1	16.2
ON BEFORE OPEN CYCLE LIGHT TIME Minimum time light is activated for prior to opening	0	255	0	1	Sec	5.2	16.2
ON BEFORE CLOSE CYCLE LIGHT TIME Minimum time light is activated for prior to closing	0	255	0	1	Sec	5.3	16.2
Menu 6 - Motor Settings							
OPEN SPEED VOLTS Voltage applied to motors when opening	12	24	22	1	VOLTS	6.1	
CLOSE SPEED VOLTS Voltage applied to motors when closing	12	24	20	1	VOLTS	6.2	
SLOW SPEED VOLTS Voltage applied to motors when slowing down	6	24	8	1	VOLTS	6.3	
SLOW TIME The time between slow down and end of cycle	0.1	10.0	3.0	0.1	SEC	6.4	

Parameter	Min	Max	Default	Step	Unit	Menu	Section
HOMING / SETUP SPEED VOLTS Voltage applied to motors when setting up the travel limits	12	24	12	1	Volts	6.5	
STOP PAUSE TIME Pause time used between motor direction changes	0.0	2.0	0.3	0.1	SEC	6.6	

Parameter	Option	Default	Menu	Section
-----------	--------	---------	------	---------

Menu 7 - Operating Modes

SB1 TYPE	2 WIRE 3 WIRE		2 WIRE	7.1	Appendix C
SB2 TYPE	2 WIRE 3 WIRE		2 WIRE	7.2	Appendix C
SB1 INPUT MODE Sets the Input mode for Safety Beam 1. Only one option can be selected.	NOT USED, CLS TO STOP OPEN INPUT CLOSE INPUT DISABLED	CLS TO REV OPN/CLS TO STOP SWIPE INPUT PED INPUT	NOT USED	7.3	Appendix C
SB2 INPUT MODE Sets the Input mode for Safety Beam 2. Only one option can be selected.	NOT USED, CLS TO STOP OPEN INPUT CLOSE INPUT DISABLED	CLS TO REV OPN/CLS TO STOP SWIPE INPUT PED INPUT	NOT USED	7.4	Appendix C
PED INPUT = SWIPE MODE Selects PED input functions as pedestrian access swipe input	Off		Off	7.5	Appendix C
OPN INPUT N/C OPERATION Selects operating polarity of OPN input	Off		Off	7.6	Appendix C
STP INPUT N/C OPERATION Selects operating polarity of STP input	Off		Off	7.7	Appendix C
REMOTE CODE ENABLED Selects remote transmitter coding function	On		On	7.8	Appendix C
VACATION MODE Selects vacation mode - disables remote control	Off		Off	7.9	Appendix C
BATTERY/SOLAR MODE Selects Battery Backup/Solar operation	BATTERY ENABLED SOLAR ENABLED		BATTERY ENABLED	7.10	Appendix C
PASSWORD Selects password protection for all changes	Off		Off	7.11	Appendix C
TX # GROUPING Selects transmitter number group display format.	Off		Off	7.12	Appendix C
OUTPUTS 1 MODE Selects function of OUTPUT1	LOCK DRIVE 3 WIRE SB 0V	LIGHT DRIVE NOT USED		7.13	Appendix C
OUTPUTS 2 MODE Selects function of OUTPUT2	LOCK DRIVE 3 WIRE SB 0V	LIGHT DRIVE NOT USED		7.14	Appendix C
FAULT AUTO RESET	Off		Off	7.15	Appendix C
SBFEC MODE	AVAILABLE DISABLED		AVAILABLE	7.16	Appendix C

Menu 8 - Diagnostics

TEST INPUTS - Controls input display status			Inactive	8.1	Appendix D
TEST TRANSMITTERS (TX'ERS)				8.2	Appendix D
DISPLAY HISTORY				8.3	Appendix D
MEMORY USAGE				8.4	Appendix D
SERVICE COUNTER			60,000	8.5	Appendix D
EVENT COUNTER				8.6	Appendix D

Appendix

A - Console Menu Structure

NOTE: The System will automatically return to the main screen after 30 secs if a menu screen is displayed and no buttons are pressed.

Parameter	Option	Default	Menu	Section
Menu 9 - Memory Tools				
CLR CONTROL			9.1	Appendix E
CLR TRANSMITTERS (TX'ERS)			9.2	Appendix E
Menu 10 - Setup Travel				
LIMIT TRAVEL			10.1	8.1
REPROFILE TRAVEL			10.2	9.5
SET PEDESTRIAN			10.3	14.1

Appendix

B - Viewing & Editing Parameters

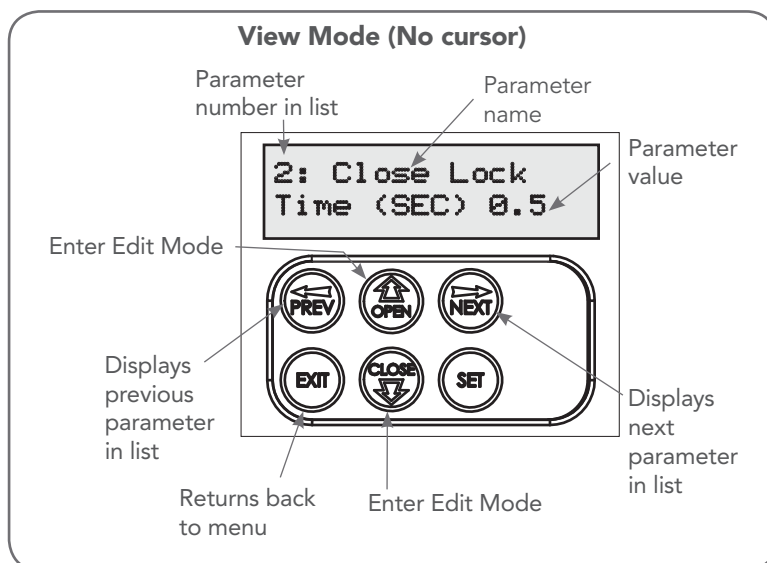

Fig B.1

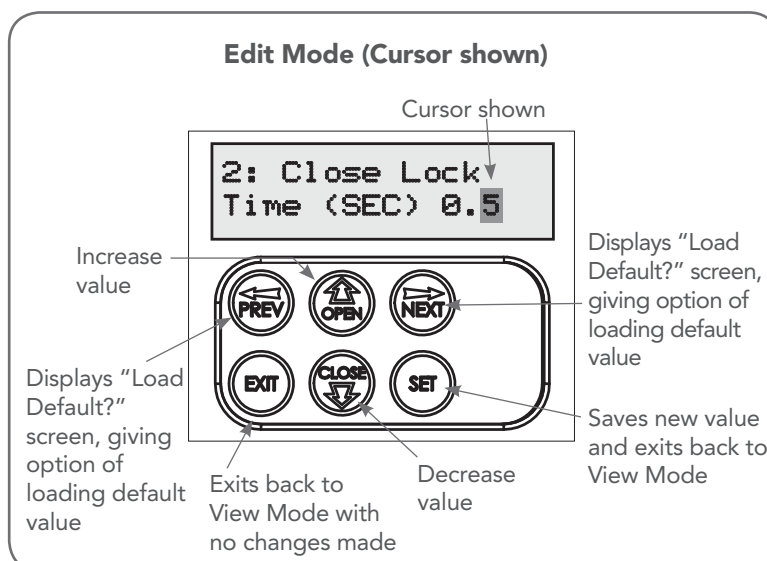

Fig B.2

This section illustrates how to locate, view and adjust parameters.

Locating parameters

Refer to Appendix A for Console Menu Structure. Locate the required parameter and note the MENU number. The example used in **(Fig. B.1)** displays "CLOSE LOCK TIME"

Changing Setting

- Press NEXT/PREV to navigate to the required menu.
- Press SET to show the sub-menu.
- Press NEXT/PREV to go to the required sub-menu.
- Press OPEN/CLOSE to enter Edit mode and change parameter setting **(Fig B.2)**.
- Holding the button down causes the parameter's value to change rapidly. The longer the button is held the faster the value changes.
- Press SET to SAVE setting.

Reload Default Setting

- Press NEXT/PREV buttons to display LOAD DEFAULT screen.
- Press SET to load the default value.

Return To Menu

If the parameter values are not to be changed, press EXIT to return to sub menu. Press EXIT again to return to the MAIN SCREEN.

Appendix

C - Wiring Dual NeoSlider Kit

Fig C.1

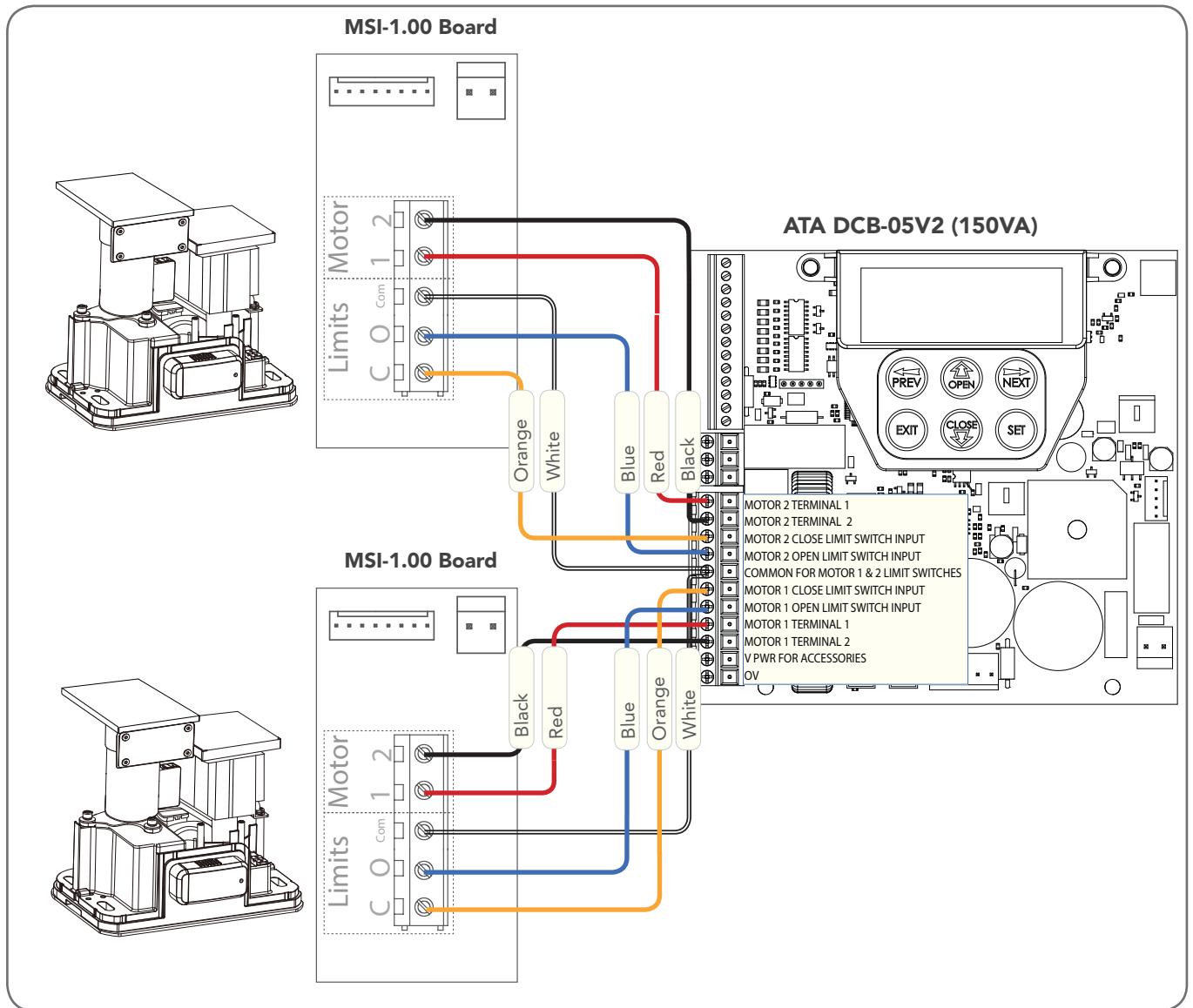

This section illustrates how to wire two NeoSlider slave units into a DCB-05V3. (**Fig. C.1**)

NOTE:

When setting limits, if both openers are travelling in different directions (i.e one is opening and the other is closing), then do the following:

- Switch over the motor wires (marked red and black in **Fig C.1**) on the incorrectly behaving openers MSI board.
- Restart the limit set up process via the DCB-05V3 Manual.

Appendix

D - Control Board Adjustments

The standard operation of the opener can be altered by editing various parameters. This section describes the parameters and the effect they have. Use the VIEWING AND EDITING PARAMETER PROCEDURE (Appendix B) to make changes.

Menu 6. Motor settings

Motor speed

The maximum speed the motors run at is controlled by the MOTOR FULL SPEED VOLTAGE parameter. The default value is the maximum recommended for normal operation. If however the gates move too quickly for a particular installation, the voltage can be reduced to make the motors run slower. **NOTE: Altering these parameters will cause the travel limits to be cleared.**

Menu 7. Operating Modes

Menu 7.1 First (SB1) Safety Beam Type

Select what type of Safety Beam (2 WIRE or 3 WIRE). 2 WIRE is default.

Menu 7.2 Second (SB2) Safety Beam Type

Select what type of Safety Beam (2 WIRE or 3 WIRE). 2 WIRE is default.

Menu 7.3 First (SB1) Safety Beam Response Mode

The Safety Beams input can be configured to respond in one of eight modes.

- i. **Not Used**
- ii. **Close to Reverse** In this mode, the Safety Beam input has no effect when opening but will cause the gate to reverse if activated when closing.
- iii. **Close to Stop** In this mode, the Safety Beam input has no effect when opening but will stop the gate when closing.
- iv. **Open and Close to Stop** In this mode, all cycles are prevented from being completed or initiated when the Safety Beam input is active.
- v. **Open input** In this mode, open cycle is initiated when the Safety Beam is activated.
- vi. **Swipe input** In this mode, open cycle is initiated when the Safety Beam is activated.
- vii. **Close input** In this mode, close cycle is initiated when the Safety Beam is activated.
- viii. **Ped input** In this mode, ped cycle is initiated when the Safety Beam is activated.
- ix. **Disabled** In this mode, Safety Beam is disabled.

Menu 7.4 Second Safety Beam (SB2) Response Mode

Same as above menu 7.3

Menu 7.5 PED Input Function

If GPI or Fire Input is selected as PED then these inputs can be configured to a SWIPE type input for pedestrian access. This provides full functionality with the Safety Beam Triggered Pedestrian Auto-Close function.

Menu 7.6 Open (Opn) Input

(Activated by OPN terminal with N/O switch, by transmitter button with OPN function assigned or by console's UP button) Activating the OPN input will cause the gate to open. Holding the input will prevent closing.

Menu 7.7 Stop (STP) Input

(Activated by STP terminal with N/O switch, by transmitter button with STP function assigned or by console's EXIT button) Activating the STP input while the gate is moving will cause the gate to be stopped. If the STP terminal is held it will prevent the gate from being moved.

Menu 7.8 Remote Code

The controller supports the Remote Code Set feature. This parameter can be used to disable the feature for security or transmitter management reasons.

Menu 7.9 Vacation Mode

Vacation mode blocks all but one designated remote transmitter from activating the NeoSlider™. The mode is activated by pressing a transmitter button with the VAC function assigned until the console displays that vacation mode is enabled (approx. 5 secs). When activated, any transmitter button which is assigned VAC will be ignored. To turn Vacation mode off, press a transmitter button with the VAC function assigned. Vacation mode can also be turned on or off manually by editing the VACATION MODE parameter.

Menu 7.10 Battery / Solar Mode

The controller can be instructed to turn off the Battery Backup / Solar facilities so that the control board can be shut down without having to disconnect the Battery Backup / Solar system.

Menu 7.11 Password Protection

The password feature enables all parameters and configuration settings to be protected unless a password is entered. When this feature is turned on, the user is requested to enter the desired password to be used. The password protection feature has a time-out that expires after 60 seconds of inactivity. Alternatively, the user may log out manually by pressing exit when the main screen is displayed.

Menu 7.12 Transmitter Grouping

The transmitter store number display format can be changed to show a grouped format. When grouping is selected, instead of displaying the store location as a number between 1 and 511, it will display as ##\$ where ## is the group number and \$ is a character a,b,c,d,e,f,g or h which indicates the group member.

Menu 7.13 Output1 Mode

AUX output can be selected to be driven by:

- i. **Lock Drive:** Lock output can be programmed for both hold and pulse mode. The operation of the lock can be programmed to activate prior to the gate and behave differently on open cycles to that on close cycle.
- ii. **Light Drive:** a light relay module can be connected on the console between V+ and OUT2 terminal which will turn the courtesy light on and off.
- iii. **3 Wire Safety Beam 0V:**
- iv. **Not Used**

Menu 7.14 Output2 Mode

AUX output can be selected to be driven by:

- i. **Lock Drive:** Lock output can be programmed for both hold and pulse mode. The operation of the lock can be programmed to activate prior to the gate and behave differently on open cycles to that on close cycle.
- ii. **Light Drive:** a light relay module can be connected on the console between V+ and OUT2 terminal which will turn the courtesy light on and off.
- iii. **3 Wire Safety Beam 0V:**
- iv. **Not Used**

Menu 7.15 Fault, Auto Reset

When selected, the controller will reset any fault automatically.

Menu 7.16 Safety Beam Failure Emergency Close Mode (SBFEC)

When a safety beam prevents movement due to any reason other than a 'real' obstruction, the user can secure their property by pressing and holding a button on the remote control or OSC on the console. The button must be held active for more than five seconds to activate this mode and hold the button for the entire duration of close cycle.

Appendix

E- Diagnostic Tools

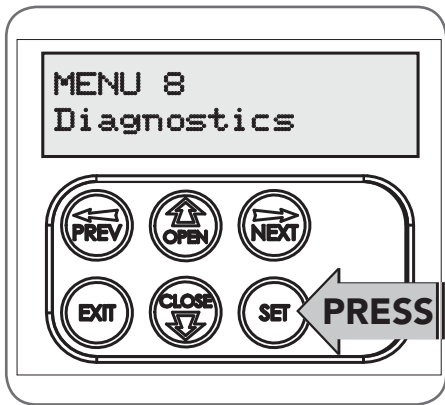

Fig E.1

The controller provides several diagnostic tools from within the Diagnostics Menu (Menu 8). This section details the function of each tool and its use.

Navigating To Diagnostics Menu

- Press PREV to navigate to Menu 8 (Fig. E.1).
- Press SET to display the menu of available functions.
- Press PREV or NEXT to cycle through diagnostic tools.
- Press SET to select.

Menu 8.1 Test Inputs

This tool is used to view the state of the control inputs. When selected, a screen is displayed (Fig. E.2) which indicates the state of each input. If the name of the input is in upper case or number in the bracket, then the input is active. Conversely if the input is in lower case, then the input is inactive. For normal operation, all inputs should be inactive. When finished, press EXIT. The example shows the status as OSC input is active.

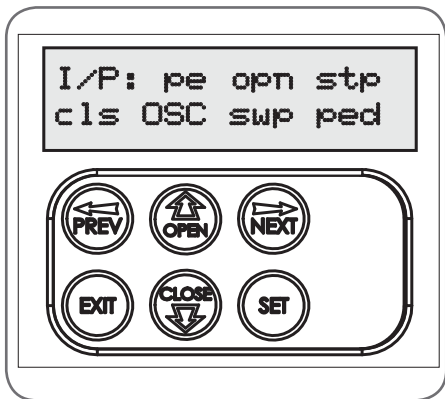

Fig E.2

Menu 8.2 Test Transmitters (Tx'ers)

This tool is used to test receiver/transmitter functionality. When selected, a screen is displayed which prompts for a transmitter button to be pressed (Fig. E.3) and whether ID or serial numbers are to be displayed.

The NeoSlider™ will then beep each time a transmission is received. If the transmitter button is stored in the NeoSlider™ memory and has a function assigned to it, a second screen will be displayed that shows the transmitter details along with the button pressed

(Fig. E.4). The example shows the case where transmitter number 12 is activated by button 4. Note ID is selected for display.

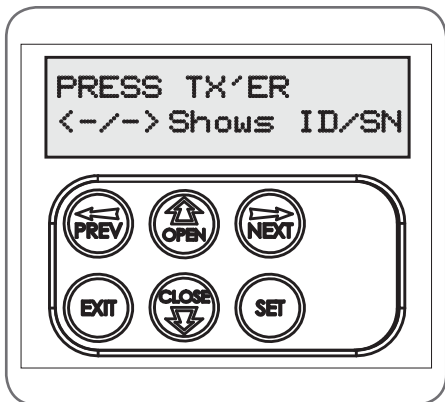

Fig E.3

Menu 8.3 Display History

The NeoSlider™ keeps a record of the last 64 events that have taken place. The events include the type of drive cycles executed, obstruction detection, various faults, power failures etc. When this tool is selected, the screen displays the last event that occurred (Fig. E.5). Press NEXT or PREV to view each event. The "EVENT#" field shows the sequence of the events, with (1) being the first and (64) being the last. The example shows that the last event was a close cycle which succeeded in closing the gate. When finished viewing the events, press EXIT.

Menu 8.4 Memory Usage

This tool displays the number of transmitter store locations used and the number free.

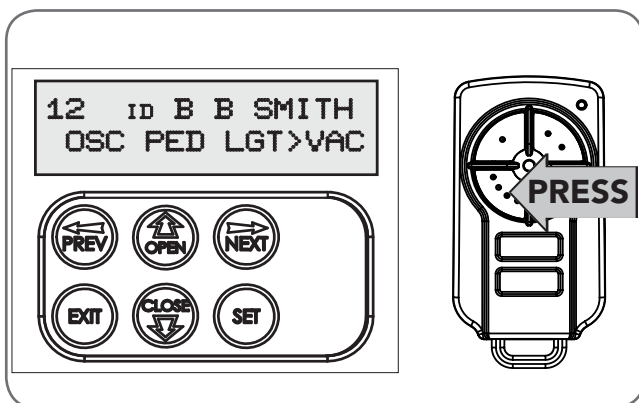

Fig E.4

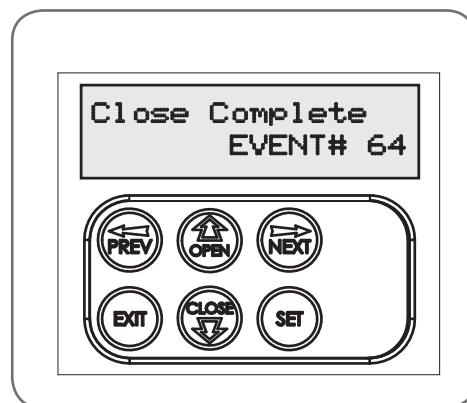

Fig E.5

Appendix

E- Diagnostic Tools

Menu 8.5 Service Counter

The NeoSlider™ provides a periodic service counter which can be set to expire after a number of drive cycles. When expired, the NeoSlider™ will beep at the beginning of each drive cycle and a message will be displayed on the MAIN SCREEN (Fig. E.6). This tool displays the current value of the service counter and allows the user to set its value using the normal parameter editing techniques (See PARAMETER VIEWING AND EDITING). If the service counter is not to be used, it can be set to the maximum number (60,000).

Menu 8.6 Event Counters

The opener keeps a count of number of times a particular event occurs. The list of event counters kept is shown below. When this tool is selected, the first event counter is shown (Fig. E.7). Press NEXT or PREV to step through the list. The example shows the OPEN CYCLE event counter with a value of 1234. When finished viewing press EXIT.

- | | |
|---------------------------|--------------------------|
| 1: Open Cycles | 2: Close Cycles |
| 3: PED Cycles | 4: Setup Limits |
| 5: Comm's Loss | 6: Sync Faults |
| 7: Overlaps | 8: M1 Open Stall |
| 9: M1 Close Stall | 10: M1 Open Obstructions |
| 11: M1 Close Obstructions | 12: M1 Open Overloads |
| 13: M1 Close Overloads | 14: M1 PWM Sync Faults |
| 15: M1 PWM Drive Faults | 16: M1 Direction Faults |
| 17: M1 Sensor Faults | |

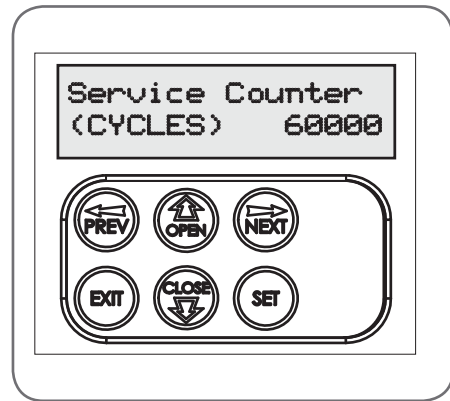

Fig E.6

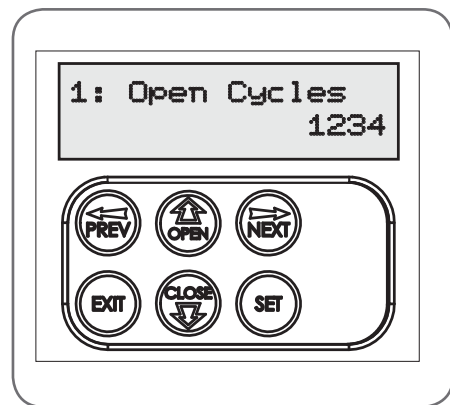

Fig E.7

Appendix

F - Memory Tools

The Memory Tools accessed from within Menu 9 (Fig F.1) are used to backup, restore or clear the controller. Once selected, the PREV or NEXT buttons can be used to view the Memory Tool options. To Execute the displayed option simply press SET.

Menu 9.1 Clear Control

This option will clear the gate control memory and reload the factory set defaults for parameters such as the lock time, light time, auto-close times etc. It will also clear the travel limits.

Menu 9.2 Clear Transmitters (Tx'ers)

This option will clear the transmitter storage memory.

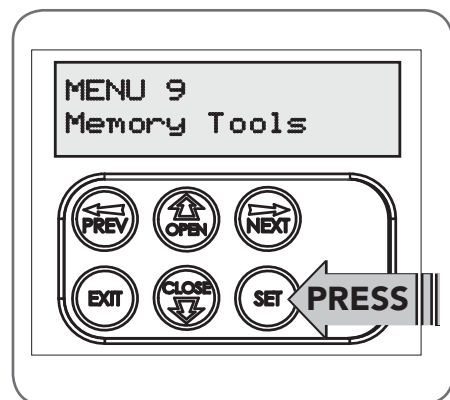

Fig F.1

Appendix

G- Transmitter Editing

Fig G.1

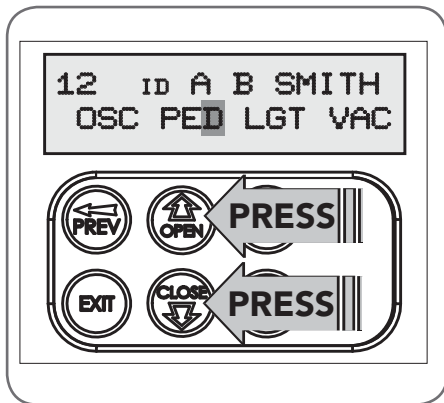

Fig G.2

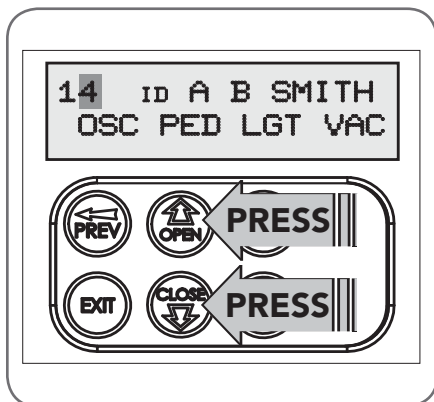

Fig G.3

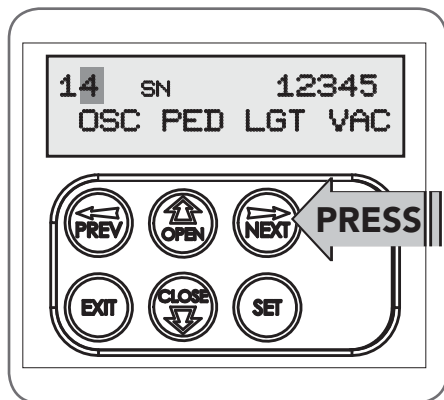
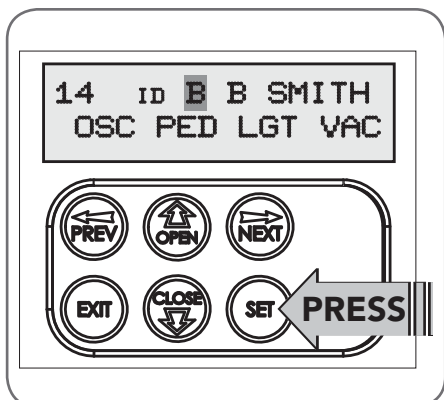

Fig G.4



Navigating To "Edit Transmitter" Menu

- Press NEXT to navigate to Menu 1 "Code Transmitter".
- Press SET to enter the transmitter edit procedure.
- Press NEXT to enter transmitter list and edit mode.

Editing Button Function Field

- Press NEXT or PREV to move the cursor to the left or right and between the top and bottom lines to select the desired field.
- Press UP or DOWN arrows to change the displayed value. The available functions are shown below. Selecting OFF will prevent the opener responding to that button.

Available functions

VAC (Vacation Mode)	LGT (Courtesy Light)
STP (Stop)	OPN (Open)
CLS (Close)	SWP (Swipe)
PED (Pedestrian access)	OSC (Open/Stop/Close)
OFF (No action)	

- Press SET to save changes or press NEXT or PREV to move to the next field. The example in **(Fig. G.1)** shows that PED is assigned to the transmitter button 2. The transmitter in the example is transmitter number 12 which has the ID label AB Smith.

NOTE: If all button functions are set to OFF, when SET is pressed, the opener will prompt to confirm if the transmitter is to be deleted. Press SET to delete or EXIT to continue editing.

Editing The Store Location

This feature is only available when coding the first button of a new transmitter.

- Press NEXT or PREV to move the cursor over Store No. **(Fig. G.2)**
- Press UP or DOWN arrows to select new Store No.
- Press SET to Confirm or NEXT/PREV to move to the next field.

This is useful when managing transmitters using a scheme which ties the store location to the transmitter's owner.

Selection Of ID or Serial Number Display

- Press NEXT to navigate to the Menu 1 "Code Transmitter".
- Press SET to enter the transmitter edit procedure.
- Press NEXT to enter transmitter list and edit mode.
- Press NEXT/PREV to move the cursor over the ID field.
- Press NEXT to reveal the Serial Number **(Fig. G.3)**.

The serial number display is provided for additional means of identification. The transmitter in this example has serial number 12345.

Editing A Character Field

- Press NEXT or PREV to move select character.
- Press UP or DOWN arrows to scroll through and select a new character.
- Press NEXT or PREV to move to the next character.
- Repeat step b.
- Press SET to record changes **(Fig. G.4)**.

The second line of the display shows a list of available characters with the current value indicated at the cursor position.

Appendix

H- Transmitter Management

Transmitter Listing Facility

The NeoSlider™ provides a transmitter listing facility which enables the user to find a transmitter location within the memory. Once located, a stored transmitter can be replaced, deleted, edited, copied or, if the location is empty, a new transmitter can be coded.

NOTE: When a transmitter is remotely coded, its ID label is set to that of the existing transmitter. If the existing transmitter does not have an ID label assigned, then the ID label of the new transmitter is set to: R/C Tx ###, where ### is the existing transmitters store number. This ensures that the originator of any remotely coded transmitter can be identified.

Method 1 - Go To The Start Of The List Accessing The List Menu

- Press NEXT to navigate to Menu 1 (**Fig. H.1**).
- Press SET to enter the transmitter edit procedure.
- Press NEXT to enter the transmitter list and edit mode.

Method 2 - Use The Transmitter To Go Direct To The List Accessing The List Menu

- Press NEXT to navigate to Menu 1 (**Fig. H.1**).
- Press SET to enter the transmitter edit procedure.
- Press the transmitter once (**Fig. H.2**).
- Press NEXT to view the transmitter parameters. This method is used for quick navigation if the transmitter is available.

NOTE: "VIEW" will not be shown if the transmitter is not stored. Once the list is displayed, it can be sorted by stored number, ID Label or Serial Number. Use the NEXT or PREV buttons to select the sorting method.

NOTE: When sorting by ID label or S/N, only stored transmitters locations are displayed.

Navigating The List

- Press the UP or DOWN arrows to navigate through the list (**Fig. H.3**).

NOTE: Holding a button down will step through the list faster.

- Press SET to display the menu of available functions.

Selecting An Operation

- Press NEXT or PREV to cycle through the four menu options (**Fig H.4**)
- Press EXIT to return to the list.
- Press SET to execute the menu's operation.

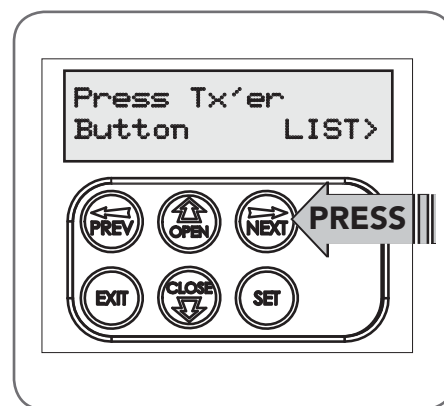

Fig H.1

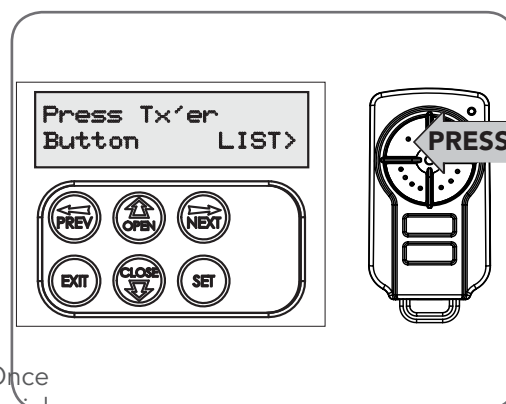

Fig H.2

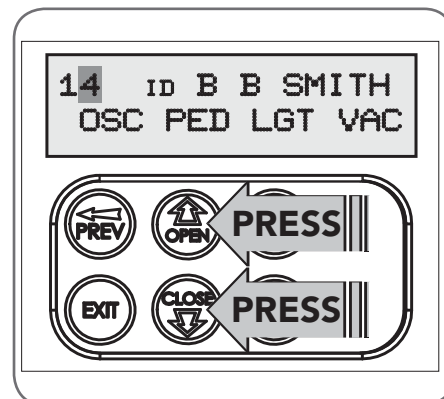

Fig H.3

Menu Option	Operation
Code Operation (location empty)	If the code operation is selected on an empty transmitter location, the BASIC CODE TRANSMITTER PROCEDURE will be initiated with the transmitter being saved in the selected location. This is useful when managing transmitters using a scheme which ties the store location to the transmitter's owner.
Code Operation (location used)	If the code operation is selected for a location that already contains a transmitter, then the BASIC CODE TRANSMITTER PROCEDURE will be initiated and the new transmitter will replace the existing one. Note that the button functions and name of the existing transmitter will be transferred to the new transmitter. This procedure is of great convenience when replacing a lost transmitter.
Delete Operation	The delete operation is used to remove a transmitter from memory along with the name and button function settings.
Edit Operation	The edit operation displays the transmitter record for editing purposes. See TRANSMITTER EDIT PROCEDURE (Appendix F) for details.
Copy Operation	The copy operation is used to code multiple transmitters with the same button function as that of the selected transmitter. Once selected an abbreviated code set routine is initiated which repeats steps 2 & 3 of the BASIC CODE TRANSMITTER PROCEDURE for each transmitter to be coded. Coding is terminated by pressing the EXIT button.
Exiting The List	To exit the transmitter list, simply press EXIT to return to the Code menu.

Fig H.4

20. Warranty and Exclusion of Liability



REGISTER ONLINE TODAY!

Register your Product to take advantage of convenient service and support at www.ata-aust.com.au/register

This Warranty is given by Automatic Technology (Australia) Pty Ltd (ABN 11 007 125 368) (ATA), 6-8 Fiveways Boulevard, Keysborough 3173, 1300 769 850, sales@ata-aust.com.au.

PLEASE NOTE:

- This Warranty is in addition to any statutory, non-excludable guarantees or warranty rights and remedies under the law. See section 5 below.
- This warranty applies to the original purchaser only and may not be transferred.
- This Warranty is to be read in conjunction with the owner's copy of the installation instruction manual.
- In this warranty, 'ATA Representative' means an entity authorized by ATA to service ATA products. Please check the ATA website for details.



The warranties below are conditional on the gate being able to run freely on its tracks / arms, without obstruction from plants, dirt or other objects.

MODEL	WARRANTY	GATE (MAX)
SLIDING		
NES-500	2 yrs / 5,000 cycles	500kg
NES-800	2 yrs / 5,000 cycles	800kg
SWING		
SGO-1V4	2 yrs / 5,000 cycles	250kg
DUAL GATE CONTROLLER		
CONTROL BOX	2 yrs / 5,000 cycles	
EXTRAS		
TRACK ASSEMBLY (includes all parts)	1 year	
TRANSMITTERS & ACCESSORIES	1 year	

3. WARRANTY EXCLUSIONS

This warranty excludes defects or improper operation resulting from:

- excessive wear and tear that may cause the product to fail;
- accidental, deliberate or negligent damage or damage caused by insects, dirt, plants or other objects;
- blown fuses, electrical surges, power surges or power spikes or faulty or unsuitable electrical wiring of structures to which the product is affixed;
- theft, fire, flood, rain, water, lightning, storms or any other acts of God;
- salt or other corrosion due to environmental conditions;
- any installation, configuration or use of the product contrary to the instructions supplied with the product;
- maximum continuous operating time exceeding 1 minute in 10 minutes;
- any obstruction (including dirt, plants or other objects) which prevents the gate from running freely;
- weight exceeding amounts listed in table above;
- the gate used with the product not being in safe working order and condition;
- any modification to the product or acts of any person in respect of the product which are not authorized by ATA;
- installation of a residential gate opener in a commercial or industrial premises or in a dwelling other than a single-family dwelling; or
- radio or electrical interference or lack of availability of signal.

4. OTHER CONDITIONS

- This Warranty is not transferable.
- The warranty period stated in the table will not be extended for Products or parts repaired or replaced during the relevant warranty period.
- Where the Product is sold by any person other than ATA, except for the warranty set out above, such person has no authority from ATA to give any warranty or guarantee on ATA's behalf in addition to the warranty set out above.

5. STATUTORY GUARANTEES OR WARRANTIES IN AUSTRALIA

If you are a consumer under the Australian Consumer Law, our goods come with guarantees that cannot be excluded under the Australian Consumer Law. You are entitled to a replacement or refund for a major failure and for compensation for any other reasonably foreseeable loss or damage. You are also entitled to have the goods repaired or replaced if the goods fail to be of acceptable quality and the failure does not amount to a major failure. This warranty certificate and other statements contained in this document or other ATA documents given to you do not exclude, restrict or modify the application of all or any of the provisions of the Australian Consumer Law.

Subject to your non-excludable rights under the Australian Consumer Law, ATA expressly excludes any liability for consequential loss, incidental or indirect damages (including but not limited to damages for loss of business profits, business interruption and loss of business information) due to a defect of the Product. In particular, any loss or damage caused to other equipment or accessories used with the product or any loss resulting from a delay in repair is excluded to the extent permitted by law.

NOTE: CONSUMABLES (eg Batteries in remote control transmitters and light bulbs and fuses) are not covered by this warranty

1. MAKING A CLAIM

- The product parts in the above table should operate in accordance with the product manual for the time period shown, provided you comply with the manufacturer's instructions concerning installation, operation, maintenance and testing. Failure to do so may void all or part of this warranty.
- If, during the relevant warranty period, a product part in the table above appears to contain a defect, call the retailer from whom you purchased the product, or ATA on 03 9791 0240, and they will instruct you what to do next.
- You are responsible for the cost of making a claim under this Warranty. Additional access expenses where the Product is not readily accessible must be borne by you.
- If ATA or ATA's Representative confirms the product is defective and covered by this Warranty, ATA will repair or replace it (at ATA's sole option) at no cost to you. Goods presented for repair may be replaced or repaired by refurbished goods or parts of the same type.

2. WARRANTY CONDITIONS

It is a condition of this warranty that:

- you provide a copy of the receipt of original purchase of the product, and the serial number of the Product which can be found on the label adhered to the Product.
- the Product has been serviced by ATA or an ATA Representative, within 12 months of installation (to allow for the gate to settle) and at regular intervals not exceeding 1 year.



© Sept 2016 Automatic Technology (Australia) Pty Ltd. All rights reserved. TrioCode™128 and NeoSlider™ are trademarks of Automatic Technology (Australia) Pty Ltd. No part of this document may be reproduced without prior permission. In an ongoing commitment to product quality we reserve the right to change specification without notice.

automatic
TECHNOLOGY

Automatic Technology (Australia) Pty Ltd

ABN 11 007 125 368

6-8 Fiveways Boulevard
Keysborough, Victoria, 3173, Australia

P 1300 133 944

E sales@automatictechnology.com.au

www.automatictechnology.com.au

SMART
SIMPLE
SECURE