

(((APC)))
Automation Systems

APC-T700S & T800S
APC-T750L & T850L

Heavy Duty 24V System
Actuator Installation Manual

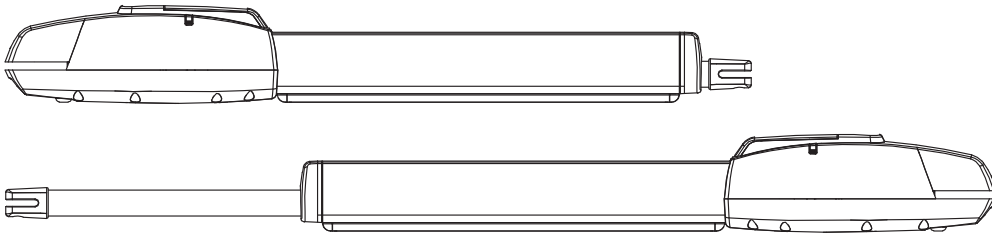

Attention Installer

The manual should be read cover to cover at least once
prior to beginning installation

Specifications

	APC-T700S	APC-T750L	APC-T800S (2x APC-T700S)	APC-T850L (2x APC-T750L)
Max gate length	4m	5m	5m Total (2x2.5m)	6m Total (2x3.0m)
Max gate weight	250kg	250kg	350kg Total (175kg x2)	500kg Total (250kg x2)
Motor Power Supply	24Vdc	24Vdc	24Vdc	24Vdc
Gear type	Worm gear	Worm gear (Metal)	Worm gear	Worm gear (Metal)
Peak Thrust	3,500N	4,500N	3,500N	4,500N
Normal Thrust	3,000N	4,000N	3,000N	4,000N
Operation Stroke	350mm	540mm	350mm	540mm
Duty Cycle	20%	20%	20%	20%
Protection grade (IP)/ Protection class	IP44	IP44	IP44	IP44
Working temperature/ Operating temperature	-20~50	-20~50	-20~50	-20~50
Absorbed current (A)	5.5A for maximum 10secs	5.5A for maximum 10secs	5.5A for maximum 10secs	5.5A for maximum 10secs
Absorbed power (W)	144W	144W	144W	144W
Manual release	key	key	key	key

The above specifications are based on perfect free flowing installations on non-cladded or covered gate using ball bearing hinges.
*Larger sized gates may require an electric lock

Preliminary Checks

To ensure safety and an efficient automation make sure the following requirements are met:

1. The gate structure must be suitable for automation.
2. Make sure that the gate leafs move properly and uniformly without any irregular friction during their entire travel.
3. The gates hinges must be in good condition with no biting, no rust and must be well greased.
4. The gates should be able to be freely opened and closed before installing the gates automation system.
5. It is strongly suggested to have a gate stop installed for the closed position.

Important Safety Information

Installer and owners should observe the following:

1. Make sure that there is sufficient space for the gate(s) to swing open fully to the desired opening angle.
2. The control Panel Box must be installed in the area within 9 meters maximum cable distance from motor and cannot be damaged.
3. Do not change with parts or components not supplied by the manufacturer, this includes sensors, buttons, solar panels, transformers and any component not listed in the compatibility list.
4. Make sure all wiring works are correct and in good condition before connecting the battery, solar panel or transformer to the control panel.
5. Turn off the power and disconnect the battery when doing any maintenance.
6. Ensure the control panel box is free from water leakage to avoid short circuiting of the control panel.
7. Do not supply mains power directly to the motor, control box or any accessories.
8. Do not install the operating system if in doubt. Contact the manufacturer.
9. Do not cross the gate while it is operating, Safety sensors are only to prevent accidents or injuries.
10. Keep the remote controls in safe place and away from children.

Before beginning installation the manual should be read thoroughly concerning all aspects of the installation including all precautions and safety information.

Proper steps should be taken to ensure efficient and safe installation for vehicles, property and persons within the operators working radius.

The system is fitted with an over current sensing feature to assist in preventing damages, injuries and death. All precautions must be taken by the installer that adjustments are set correct based on the gates weight, height and length. The system sensitivity should be set to allow consistent operation of the gates under normal operating conditions. This does not include operating against wind. The system may not detect (Over current sense) against light loads such as small object, young children and animals. It is the operators duty to ensure that the area is clear prior to operation. Photo sensors or Reflective sensors should always be installed to assist in accident or death prevention. Rubber edging should be installed onto the gates to assist in dampening any accidents or damages.

You agree to install this product following any and all safety requirements listed in this manual or required under local, state or national regulations. APC Australia, its distributors, stockist or sellers are not liable for any direct, indirect, incidental, special or consequential damages or loss of profit wether based in contract or any other legal theory during the course of warranty or afterwards. If you do not feel capable of properly installing the operator based on the above information or otherwise do not proceed.

Tools Required

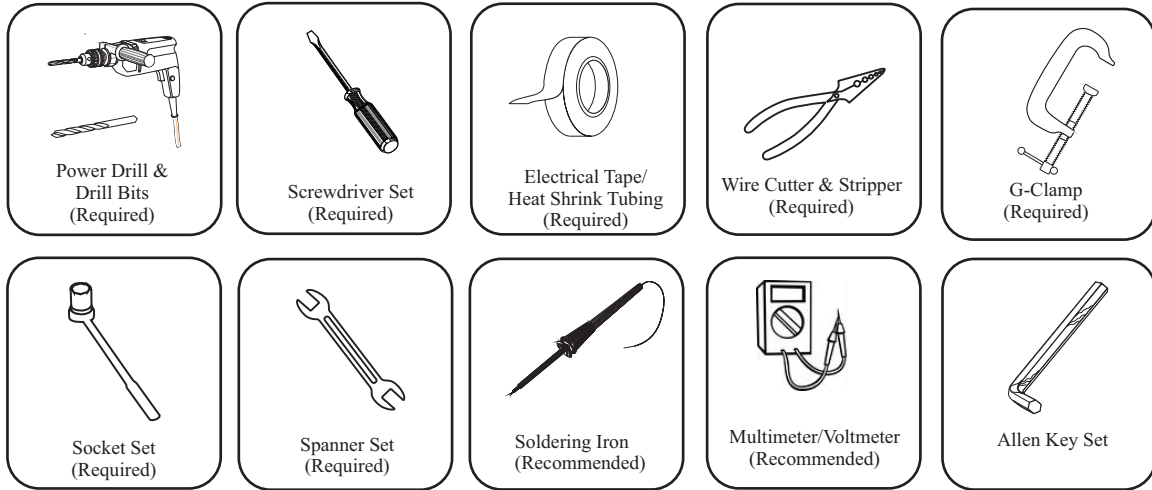

Motor Stroke & Bracket Dimensions

UNDER NO CIRCUMSTANCES SHOULD THE EXPANDED STROKE OF THE MOTOR BE USED AS A LIMIT

APC-T700

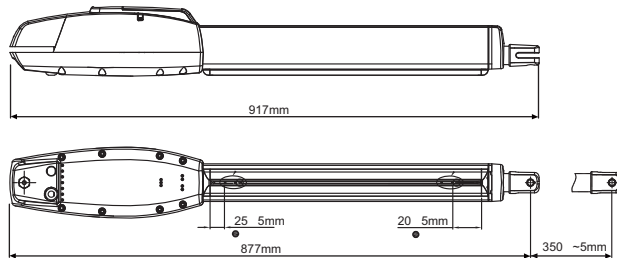

Gate Bracket

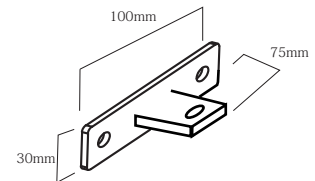

APC-T750L

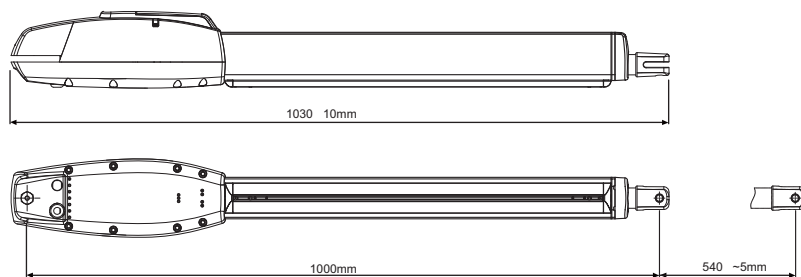

Post Bracket

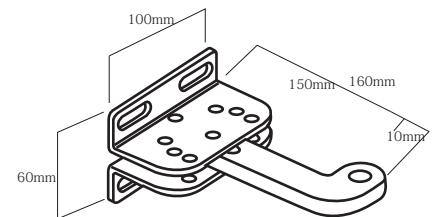

Clutch Override

In case of an emergency or requirements during installation the gate can be moved open and close by hand operation if the clutch is disengaged. To disengage the clutch follow the procedure below.

1. Slide forward the top cover.
 2. Insert the key and turn to the unlock symbol.
 3. Turn the knob by 180° toward the open writing.
- (The indentation on the knob should line up with the arrow head on the actuator body)

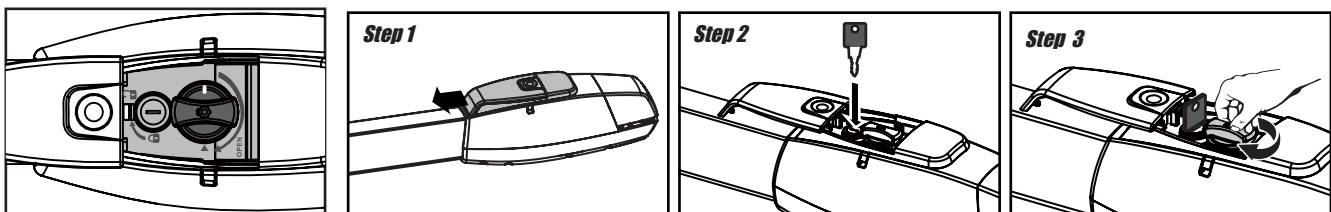

Ensure that the knob is always straight prior to closing the top cover to prevent damage or breakage

Limit Switch Wiring (Pre-Wired)

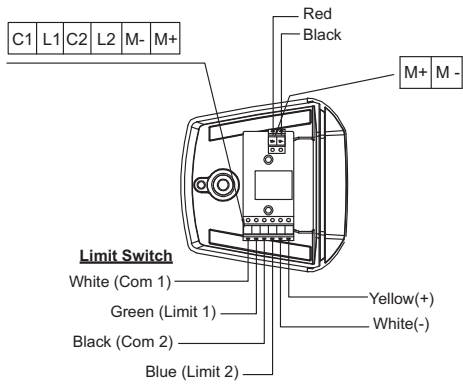

Post Bracket Manipulation

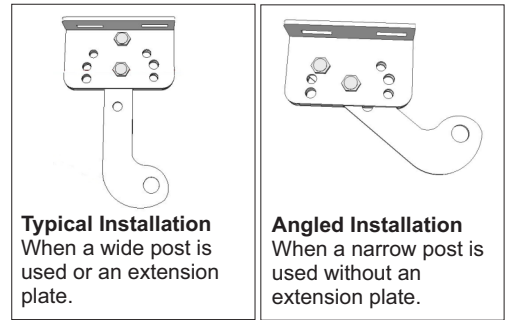

Post installation methods

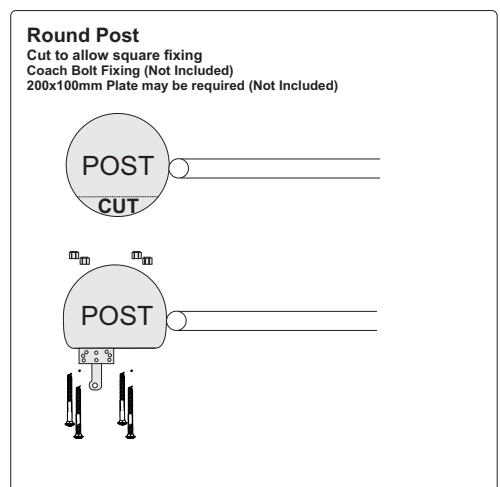
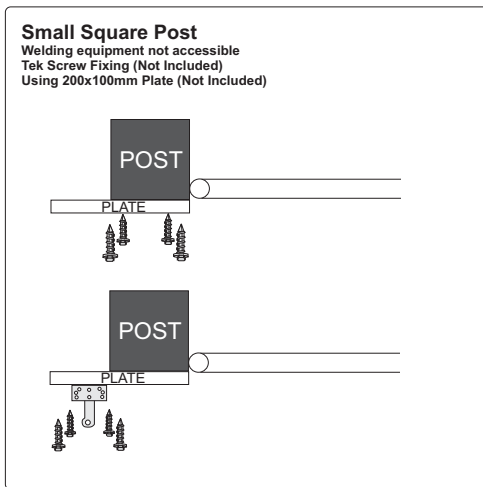
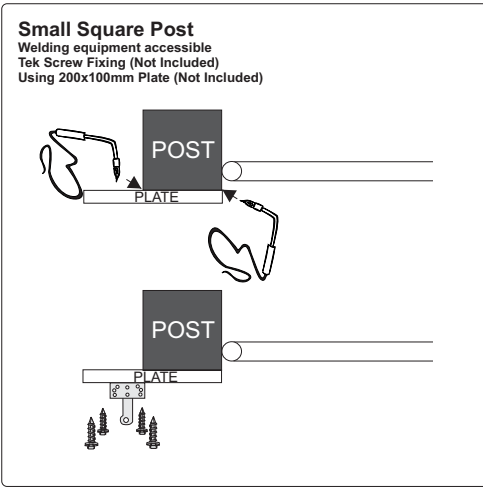

Gate Stop Installation

Before beginning the installation of the gate motors a physical gate stop must be installed at the closed position.

For Single gate systems the gate stop can be installed in two different methods.

1. On the driveway itself at the furthest point from the hinge as illustrated in the diagram below (Fig 1).
2. On the post that the gate will close too (Fig 2).

For Double gate systems the gate stop must be installed in the center of the driveway stopping both gates (Fig 3).

When installing on the driveway itself it is recommended to use a rubber floor stop to prevent damage to vehicle entering and exiting.

When installing on the post for single gate installations a 90° angle can be used with a rubber padding to dampen or soften the close and prevent damage to the gate.

UNDER NO CIRCUMSTANCES SHOULD THE EXPANDED STROKE OF THE MOTOR BE USED AS A LIMIT

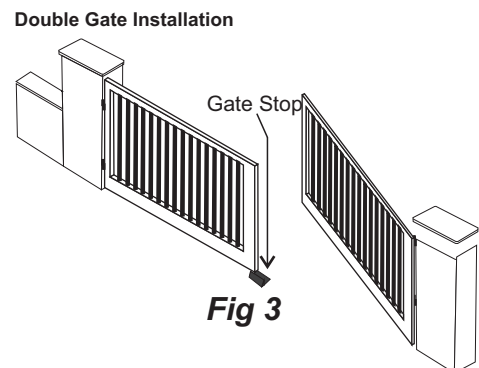
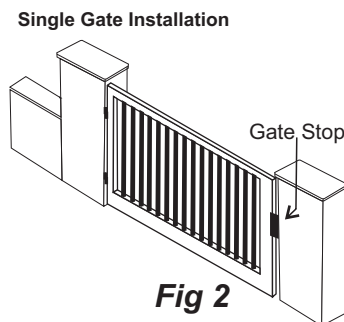
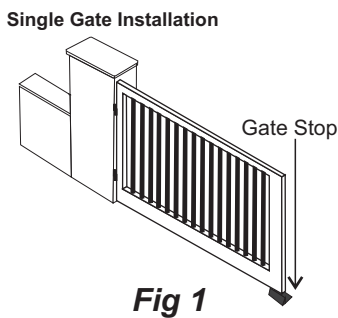

Pull to Open Installation

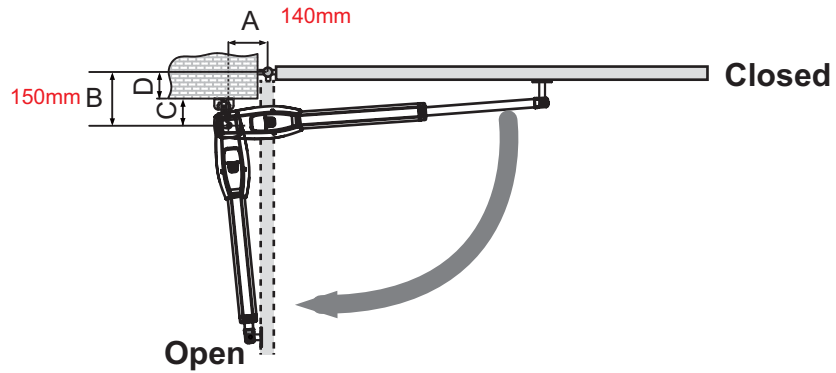

- 1** Install the center of the post bracket inline with the center of your gates horizontal rail using the supplied dimensions above.

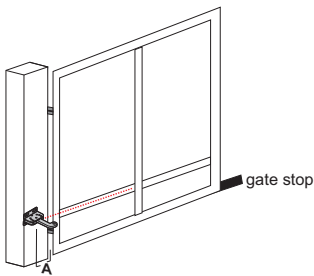

- 2** a) Retract the actuator to 120mm from the end of stroke (120mm of stainless piston showing).
b) Open the gate to the desired open angle.
c) Install the gate bracket onto the actuator.
d) Install the actuator onto the post bracket.

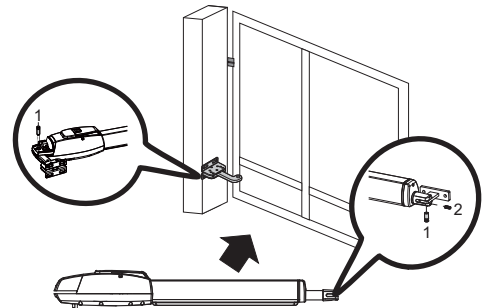
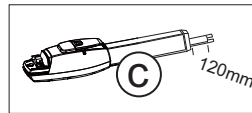

- 3** a) Use a bubble level to ensure the actuator is straight then mark the two gate bracket fixing holes on the gates rail.
b) Disconnect the gate bracket from the actuator.

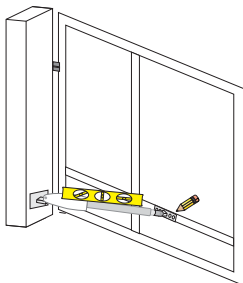

- 4** Install the gate bracket onto the gate then re-install the actuator to the gate bracket.

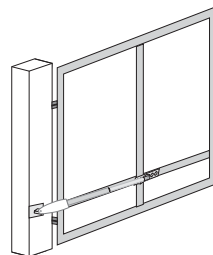

Motor installation complete
Repeat steps 1 to 4 for second gate if applicable

Adjusting Limits for Pull to Open

- Loosen the desired limit switch (A is for open, B is for closed).
- Slide the limit forward/ back to an approximate position then tighten.
- Test the position by applying power to the actuator using the 24V battery to the end of the 6 meter motor cable
DO NOT APPLY POWER DIRECTLY TO THE CIRCUIT BOARD
- Re-adjust if necessary and re-test until the positions are correct.

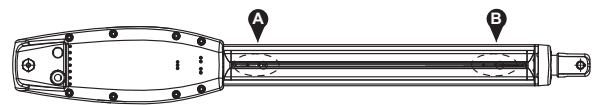

Polarity for EXPANDING the actuator

24V Battery arrangement must be used (will not function on 12V)
Red to - on Battery 1
Black to + on Battery 2

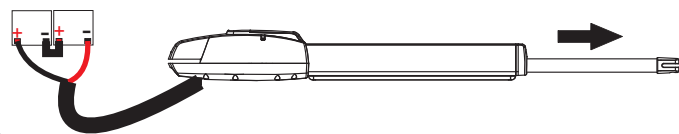

Polarity for RETRACTING the actuator

24V Battery arrangement must be used (will not function on 12V)
Black to - on Battery 1
Red to + on Battery 2

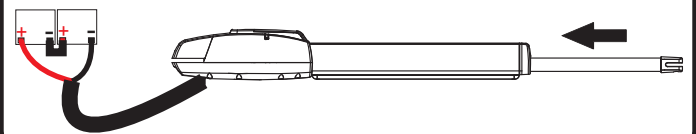

Push to Open Installation

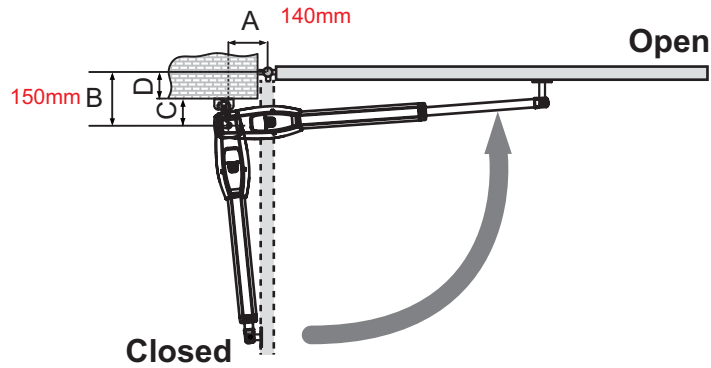

- 1** Install the center of the post bracket inline with the center of your gates horizontal rail using the supplied dimensions above.

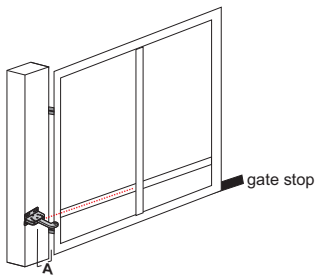

- 2** a) Retract the actuator to 120mm from the end of stroke (120mm of stainless piston showing).
 b) Close the gate to the desired closed position.
 c) Install the gate bracket onto the actuator.
 d) Install the actuator onto the post bracket.

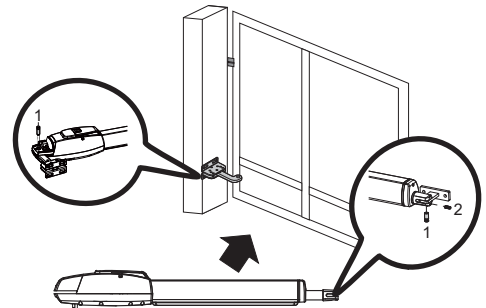
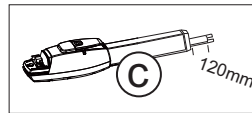

- 3** a) Use a bubble level to ensure the actuator is straight then mark the two gate bracket fixing holes on the gates rail.
 b) Disconnect the gate bracket from the actuator.

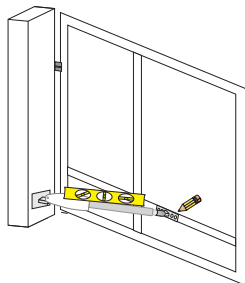

- 4** Install the gate bracket onto the gate then re-install the actuator to the gate bracket.

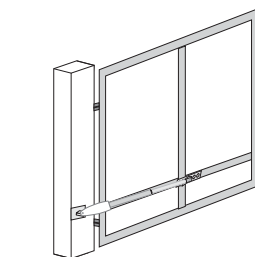

Motor installation complete
 Repeat steps 1 to 4 for second gate if applicable

Adjusting Limits for Push to Open

- Loosen the desired limit switch (A is for close, B is for open).
- Slide the limit forward/ back to an approximate position then tighten.
- Test the position by applying power to the actuator using the 24V battery to the end of the 6 meter motor cable
- Re-adjust if necessary and re-test until the positions are correct.

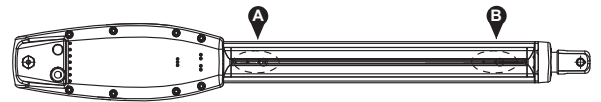

Polarity for EXPANDING the actuator

24V Battery arrangement must be used (will not function on 12V)
 Red to - on Battery 1
 Black to + on Battery 2

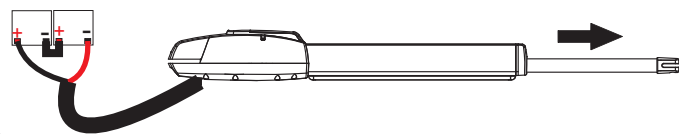

Polarity for RETRACTING the actuator

24V Battery arrangement must be used (will not function on 12V)
 Black to - on Battery 1
 Red to + on Battery 2

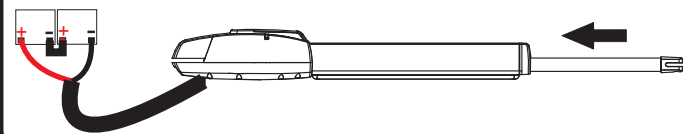

Pull to Open Motor Wiring

Pull-To-Open

Pull-To-Open

M1 opens FIRST
M2 opens SECOND

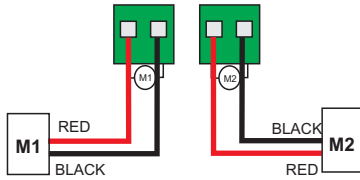

Push to Open Motor Wiring

Push-To-Open

Push-To-Open

M1 opens FIRST
M2 opens SECOND

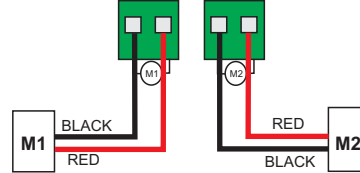

Please follow the above motor connections then proceed to the APC-CBSW24 control panel manual.

(((APC))) Automation Systems

APC WARRANTY

APC warrants the original purchasers or the APC gate(s) opening system for a period of twelve months from the date of purchase (not installation), the product shall be free of defects in materials and workmanship under normal use.

During the warranty period, APC shall, as its option, repair or replace any defective product upon return of the product to its factory, at no charge for labour and materials.

Any replacement and/or repaired parts are warranted for the remainder of the original warranty,

The original owner must promptly notify APC in writing that there is defect in material or workmanship, such written notice must be received in all events prior to expiration of the warranty.

International Warranty

APC shall not be responsible for any freight fees, taxes or customs fees.

Warranty Procedure

To obtain service under this warranty, AND AFTER CONTACTING APC, please return the item(s) in question to the point of purchase.

All authorized distributors and dealers have a warranty program, anyone returning goods to APC must first obtain an authorization number. APC will not accept any shipment for which prior authorization has not been used.

Conditions to Void Warranty

This warranty applies only to defects in pairs and workmanship relating to normal use. It does not cover:

- Damage incurred in shipping or handling
- Damage caused by disaster such as fire, flood, wind, earthquake or lightning
- Damage due to causes beyond the control of APC such as excessive voltage, mechanical shock or water damage
- Damage caused by unauthorized attachment, alterations, modifications, or foreign objects.
- Damage caused by peripherals (unless such peripherals were supplied by APC)
- Defects caused by failure to provide a suitable installation environment for the products
- Damage caused by usage of the products for purpose other than those for which it was designed.
- Damage from improper maintenance
- Damage arising out of any other abuse, mishandling, and improper application of the products.

Under no circumstances shall APC be liable for any special, incidental, or consequential damages based upon breach of warranty, breach of contract, negligence, strict liability, or any other legal theory. Such damages include, loss of profits, loss of the product or any associated equipment, cost of capital, cost of substitute or replacement equipment, facilities or services, down time, purchaser's time, the claims of third parties, including customers, and injury to property.

Disclaimer of Warranties

This warranty contains the entire warranty and shall be in lieu of any and all other warranties, whether expressed or implied (including all implied warranties of merchantability or fitness for a particular purpose). And of all other obligations or purporting to act on its behalf to modify or to change this warranty, nor to assume for it any other warranty or liability concerning this product.

Out of Warranty Repairs

APC will at its option repair or replace out-of-warranty products which are returned to its factory according to the following conditions. Anyone returning goods to APC must first obtain an authorization number.

APC will not accept any shipment whatsoever for which prior authorization has not been obtained. Products which APC determines to be repairable will be repaired and returned. A set fee which APC has been predetermined and which may be revised from time to time will be charged for each unit repaired. Products which APC determines not repairable will be replaced by the nearest equivalent product available at that time. The current market price for the replacement product will be charged for each replacement unit.