



Automation Systems

APC-SG801AC & APC-SG1600AC Sliding Gate Opener



Keypad
Input



Push Button
Input

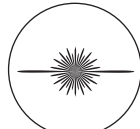

Safety Beam
Ready



Smart
Sensitivity

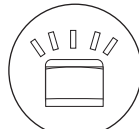

Courtesy Light
Output

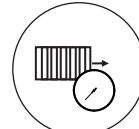

Auto Close



Lockout Mode



WARNING

ALL EQUIPMENT IS HIGH VOLTAGE AND SHOULD BE
INSTALLED BY A QUALIFIED ELECTRICIAN

Attention Installer

The manual should be read cover to cover at least once
prior to beginning installation

Preliminary Checks

To ensure safety and an efficient automation make sure the following requirements are met:

1. The gate structure must be suitable for automation.
2. Make sure that the gate moves properly and uniformly without any irregular friction during their entire travel.
3. The gates wheels and track must be in good condition with no biting, no rust and must be well greased.
4. The gates should be able to be freely opened and closed before installing the gate automation system.
5. It is strongly suggested to have a gate stop installed for the open position for emergency purposes.

Important Safety Information

Installer and owners should observe the following:

1. Make sure that there is sufficient space for the gate to slide open fully without interference.
2. Do not change with parts or components not supplied by the manufacturer, this includes sensors, buttons, and any component not listed in the compatibility list.
4. Make sure all wiring works are correct and in good condition before applying power to the system.
5. Turn off the power when doing any maintenance.
6. Ensure the control panel is not exposed to water to avoid short circuiting of the control panel.
7. Do not supply mains power directly to the motor, control box or any accessories.
8. Do not install the operating system if in doubt. Contact the manufacturer.
9. Do not cross the gate while it is operating, Safety sensors are only to prevent accidents or injuries.
10. Keep the remote controls in safe place and away from children.

Before beginning installation the manual should be read thoroughly concerning all aspects of the installation including all precautions and safety information.

Proper steps should be taken to ensure efficient and safe installation for vehicles, property and persons within the operators working radius.

The system is fitted with an over current sensing feature to assist in preventing damages, injuries and death.

All precautions must be taken by the installer that adjustments are set correct based on the gates weight, height and length.

The system sensitivity should be set to allow consistent operation of the gates under normal operating conditions.

The system may not detect (Over current sense) against light loads

such as small object, young children and animals. It is the operators duty to ensure that the area is clear prior to operation.

Photo sensors or reflective sensors should always be installed to assist in accident or death prevention.

You agree to install this product following any and all safety requirements listed in this manual or required under local, state or national regulations. APC Automation Systems, its distributors, stockist or sellers are not liable for any direct, indirect, incidental, special or consequential damages or loss of profit whether based in contract or any other legal theory during the course of warranty or afterwards. If you do not feel capable of properly installing the operator based on the above information or otherwise do not proceed.

Photo evidence of the installation will be required to assist in warranty product claims.

Typical Installation Layout

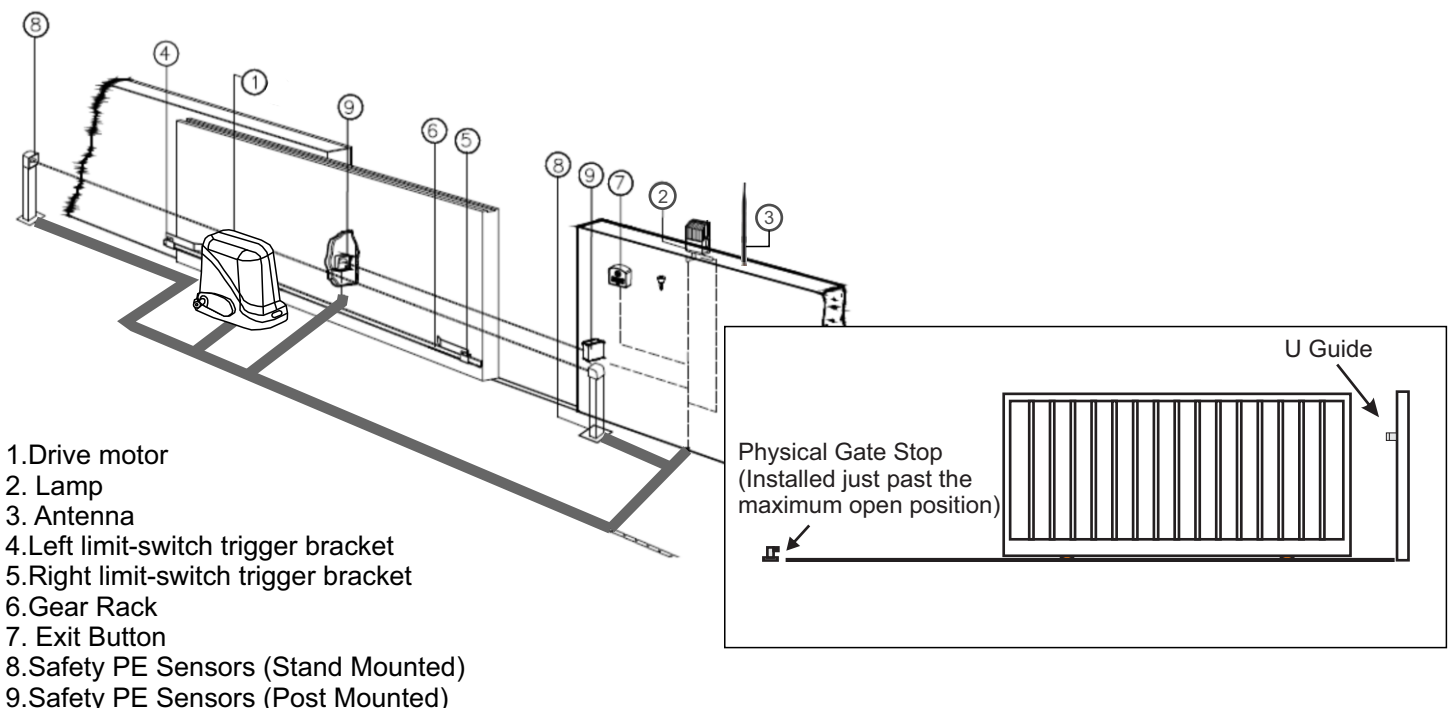

Specifications and Features

APC-SG801AC

Working temperature of motor: $-25^{\circ} \sim +55^{\circ}$
Working humidity: $\leq 85\%$
Power supply: $220V \pm 10\%$ 50Hz
Rated power: 450W
Open(close) speed: 12m/min
Maximum pull: 22Nm
Maximum load: 800kg

APC-SG1600AC

Working temperature of motor: $-25^{\circ} \sim +55^{\circ}$
Working humidity: $\leq 85\%$
Power supply: $220V \pm 10\%$ 50Hz
Rated power: 650W
Open(close) speed: 12m/min
Maximum pull: 38Nm
Maximum load: 1600kg

Features

1. Totally integrated electrical mechanical system
2. Control board interface for photocell's, keypads, press buttons and other access control
3. Individual open, stop and close terminals
3. Safety lamp connection
4. Automatic close
5. Wireless remote controls, keypads or press button compatible
6. Automatically stops and re-open when an obstacle is encountered
7. Adjustable resistance sensitivity

Tools Required

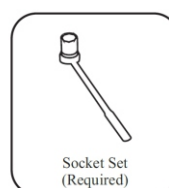
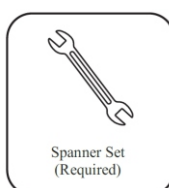
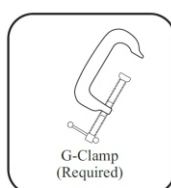

Standard Kit Contents

Standard Motor Kit Contents

1. Sliding Gate Motor
2. RHS Limit Switch Striker Plate
3. LHS Limit Switch Striker Plate
4. Motor cover screws
5. Motor Base Plate
- 6 Striker Plate Fixing Bolts
7. Override keys
8. Motor to mounting plate screws

Dimensions

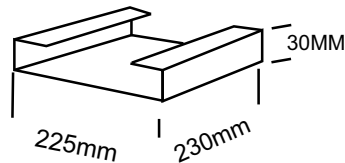
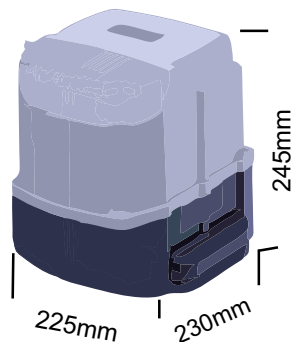

Important Notes

1. Do not operate the gate if there are people or obstacles in the gate's path.
2. The power supply for the control board should be equipped with a separate switch with a fuse rated at 10AMP.
3. Always disconnect the power supply before attempting any service or repairs on the sliding gate.
4. The rack must be fixed securely and in a straight line parallel to the gate track, it must also sit squarely over the drive gear.
5. Ensure the gap between the rack and drive gear is adequate to avoid excessive load on the drive gear.
6. Confirm the direction of the moving gate, the supplied gate stops should be installed in a right position to avoid the motor running out of control.

Motor Positioning and fixing

A- Decide on the position that is most suitable to install the motor.

B- Temporarily fit the base plate under the motor housing and place in the position the gate opener will be fitted, be sure to position the base plate about 65mm away from the gate (see Diagram 1).

Note: Place one piece of Gear rack on top of the pinnion to ensure that you have the right height to install the gear rack

C- Mark around the base plate

D- Remove the motor housing

E- Mark the 4 holes position to be drilled for the base plate.

NOTE: Ensure motor base plate is level, if not make the necessary adjustments to rectify.

F- Drill the 4 holes.

G- Fix the base plate using the appropriate screw (for metal) or dyna bolts (for concrete).

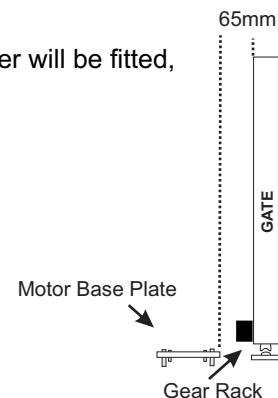

Clutch Override

Using the supplied key unlock the to manual override mode by turning the key clockwise. Now you can open and close the gate manually.

To return to automatic (re-engage) turn the key anti-clockwise.

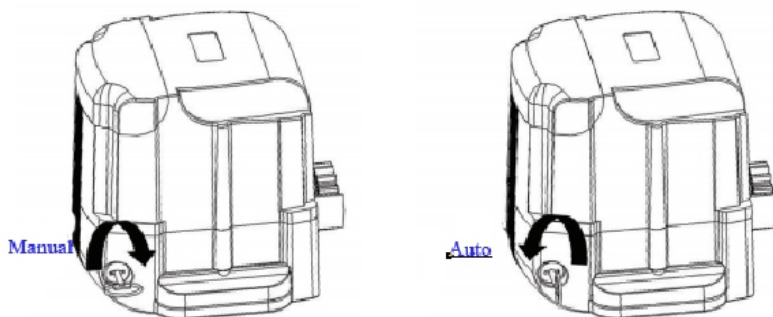

Each piece of rack will interlock into the next piece (see diagram 3)

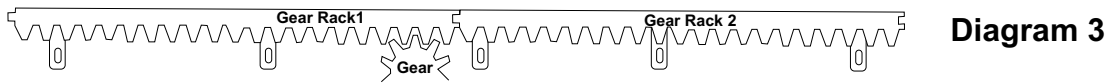

- The best method for installation is to first close the gate using the manual override, sit the first piece on the gear of the motor (make sure it is 100% level first) then fix directly to the gate in the centre of the fixing hole of the rack. Now loosen the fixing and adjust the spacing between the motor gear and the gear rack (allow 2-3mm gap as illustrated in diagram 5)

- Re-tighten and fix the next remaining holes on the rack. Move the gate manually forward and backward along the installed rack to ensure that the gap between the rack and the gear is consistent throughout. Clip in the next piece of rack into the first (make sure it is 100% level first) then fix directly to the gate in the centre of the fixing hole of the rack.

- Again move the gate manually forward and backward along the installed racks to ensure that the gap between the rack and the gear is consistent throughout. Repeat the above method to complete the racks installation and always be sure to move the gate manually forward and backward every time you install another piece of the rack.

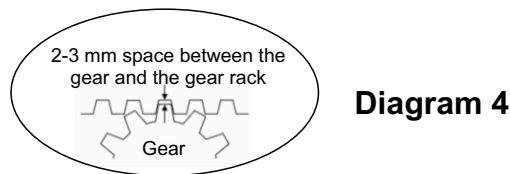

- The striker plates must be installed now to set the open and close positions for the motors operation. They are fixed onto the gear rack and should strike the limit switch spring on the motor to set the operating parameter (see diagram 6).

- Using the manual override open the gate to the desired open position and install the open striker then close the gate to the desired position and install the closed striker (small adjustment afterwards may be necessary to achieve the best results when the motor is powered later).

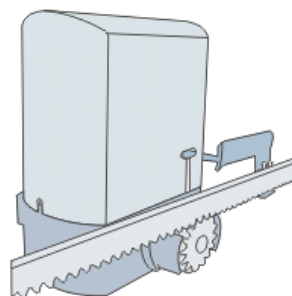
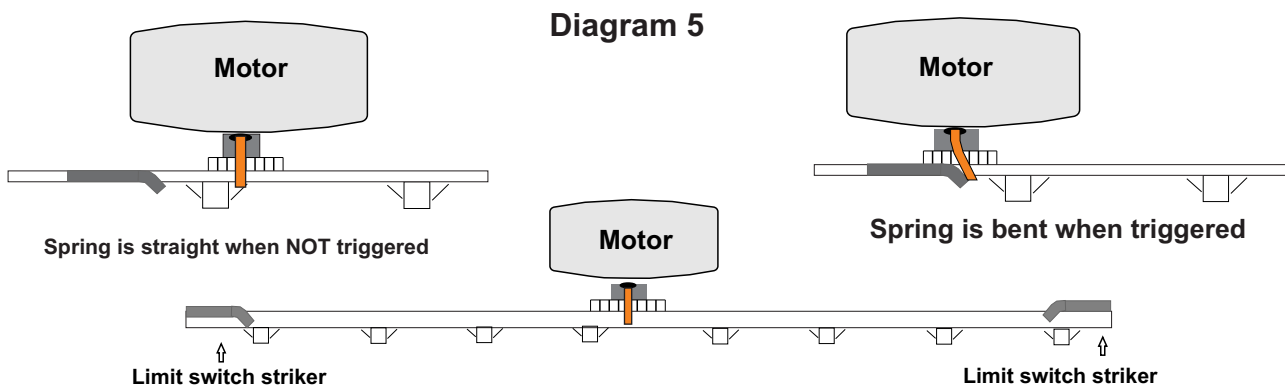

Illustration of gear rack, striker plate and the gate motor

Setting the operating direction

Before Power up

The wiring on the control board is set for **LHS Opening (left hand side opening installation)**

Adjust the limit plug and the directional switch as per illustration below to change the operating direction to right hand side if required.

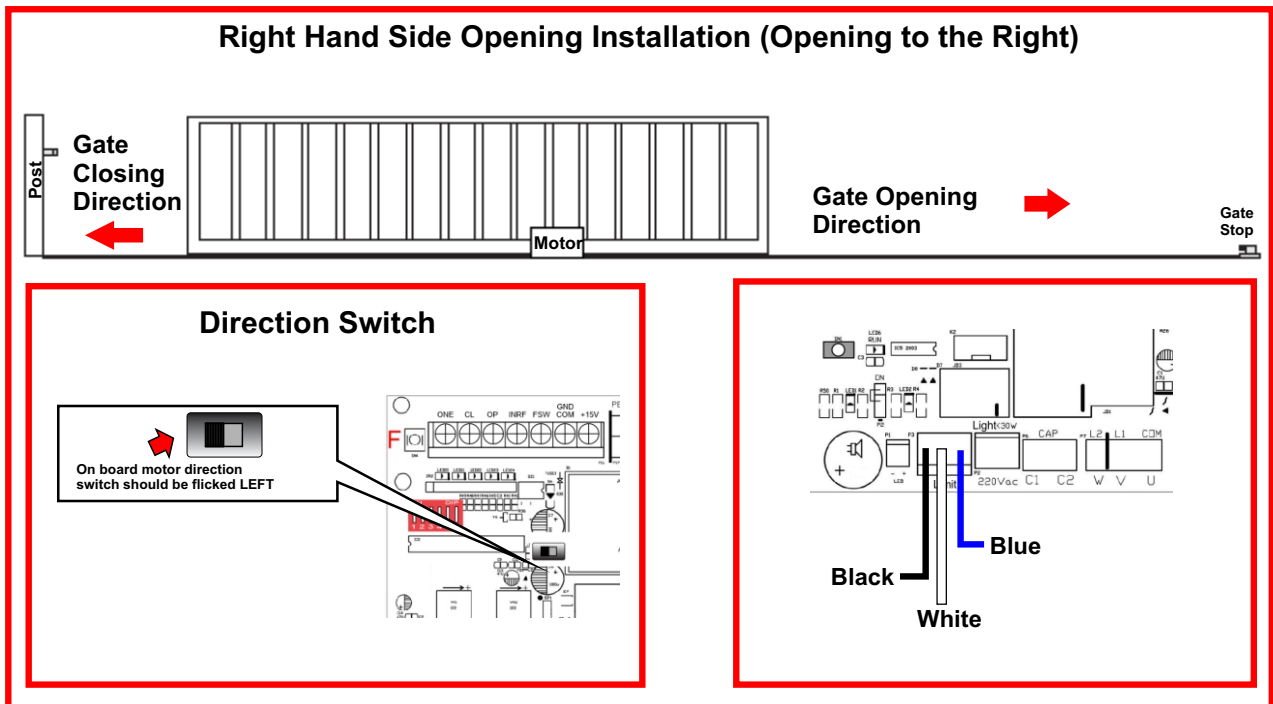
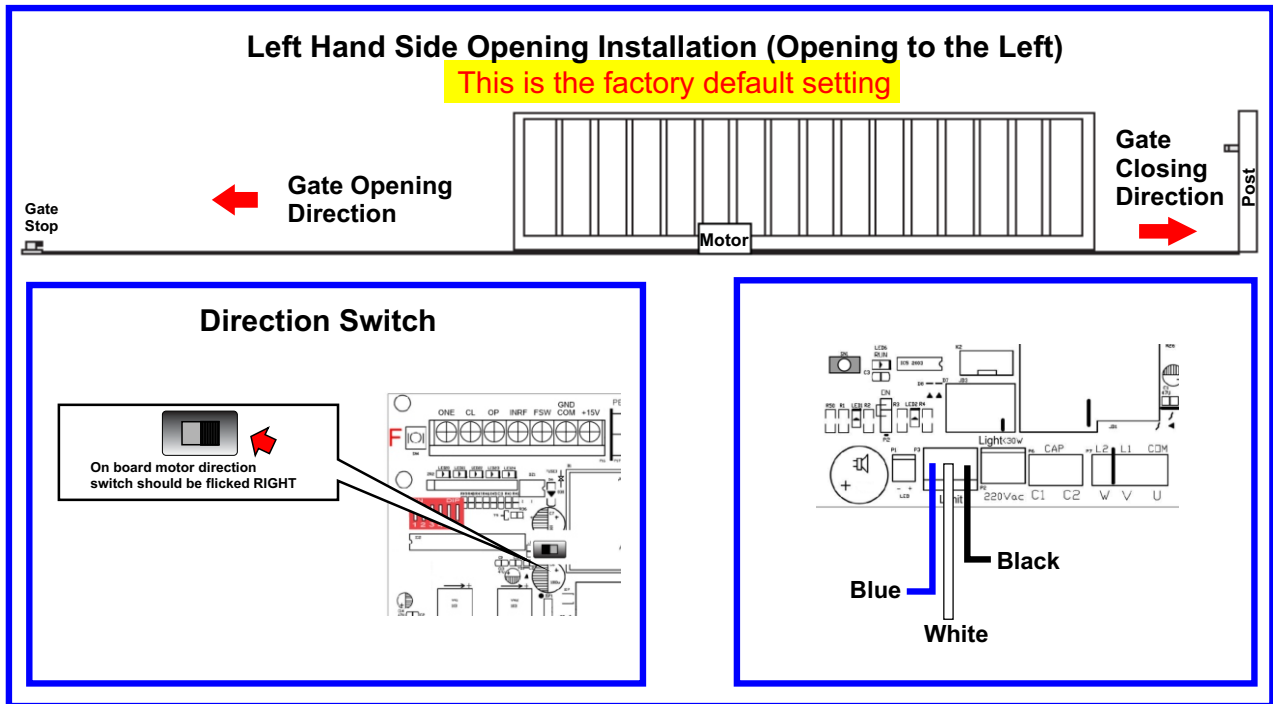

Power Up and Testing Procedure

- Check the operating direction wiring and switch again
- Close the gate using the manual override
- Re lock the manual override
- Connect the power cord to a 10amp power point
- Press number 1 on the remote control to start your test
- The gate should open and stop when the limit switch spring is triggered

If the gate does not stop when the spring is triggered then please re-check you wiring and direction switch as per above

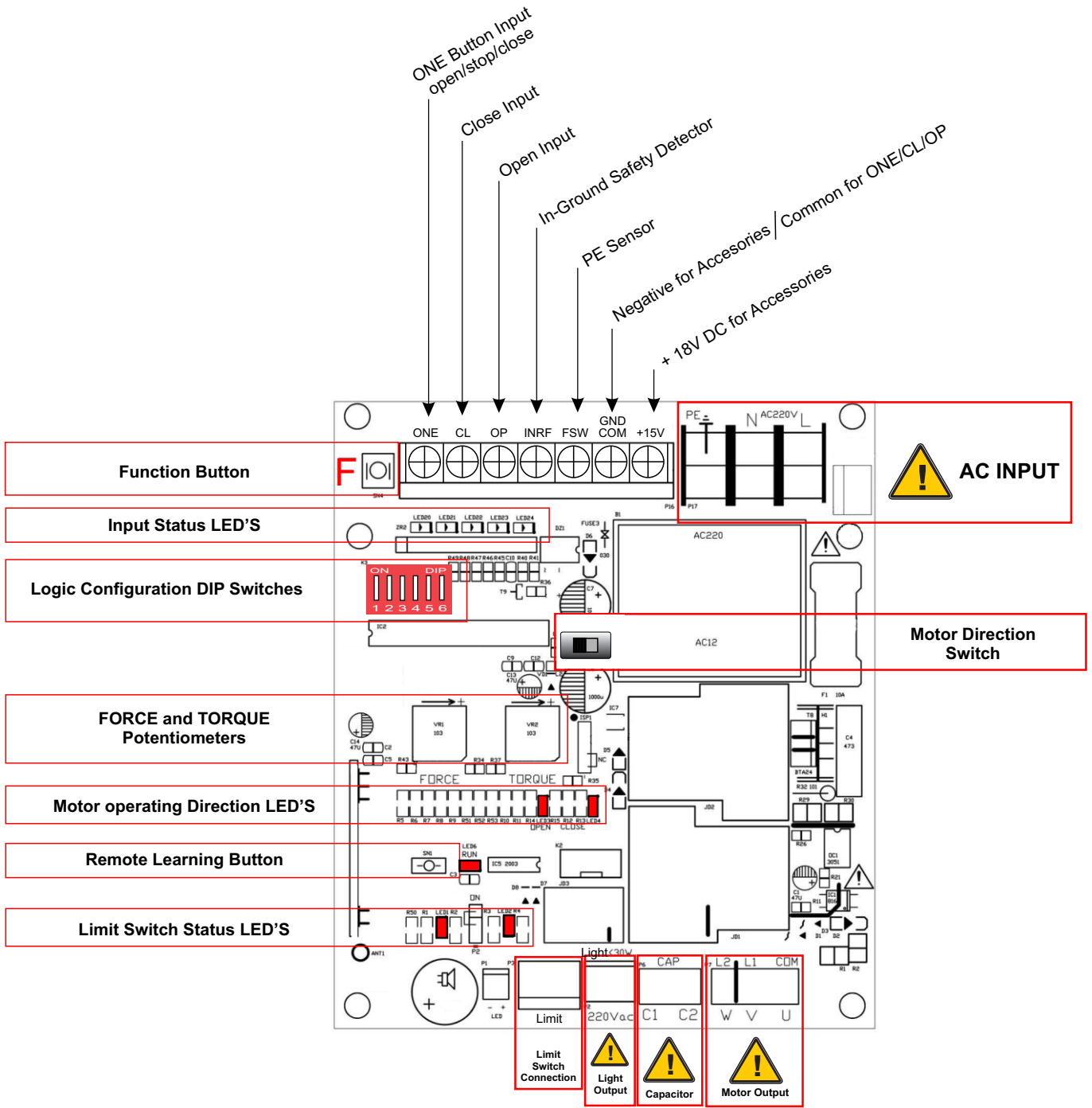

Using your Wireless Equipment

<p>Single Button Mode</p> <p>Open/Stop/Close</p> <p>APC-RC4S 20 Metre Operational Range*</p>	<p>Multi Key Mode</p> <p>Open Close Unlock/Stop Lock</p> <p>APC-RC4S</p>
--	--

<p>Single Button Mode</p> <p>Open/Stop/Close</p> <p>APC-RC450S 400+ Metres Operational Range*</p> <p>On/Off Switch</p>	<p>Multi Key Mode</p> <p>Open Close Stop/Unlock Lock</p> <p>On/Off Switch</p>
--	--

Type in the 4 digit pin code then press #

Single Button Mode
1111# For Open/Stop/Close

Multi Key Mode
1111# For Open
2222# For Close

APC-KP2W
15 Metre Operational Range*

Activate the Push Button by turning the key switch to the ON position.

Press the button to operate.

PBS-KW
5 Metre Operational Range*

Single Button Mode
For Open/Stop/Close

Multi Key Mode
Each button can be configured for either open or close.

TORQUE Potentiometer and Auto Reverse Function

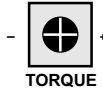

To adjust the power of the gate motor you can and also enable the auto reverse function DIP 5 will need to be adjusted to the ON position.

Adjusting the TORQUE potentiometer anti-clockwise will decrease the motor power and increase its sensitivity. Adjusting the TORQUE potentiometer clockwise will increase the motor power and decrease its sensitivity.

Note 1: TORQUE is not always a practical feature for higher weight gates, sloping driveways and it would be recommended to have this feature disabled in such scenarios where it would not be practical to use and ensure the correct safety sensors are installed in such an application.

Startup FORCE Potentiometer



The FORCE adjustment is to adjust the initial startup power of the motor (first 2-3 seconds of the cycle). The FORCE adjustment when adjusted clockwise will increase the startup power, if adjusted anti-clockwise will decrease the startup power.

To enable the FORCE feature please adjust DIP 4 into the ON position.

Note 1: FORCE is not a valid feature for higher capacity gate motors and will see minimal difference.

Note 2: It is expected to have a momentary pause/dip in power during the transition from startup force to normal operation.

LED Indicators

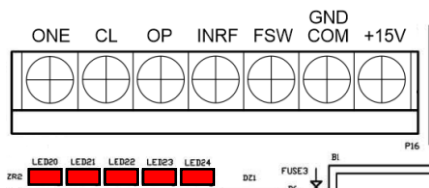

- LED 20:** Illuminated when the ONE input is triggered.
- LED 21:** Illuminated when the CL input is triggered.
- LED 22:** Illuminated when the OP input is triggered.
- LED 23:** Illuminated when the INRF input is triggered.
- LED 24:** Illuminated when the FSW input is triggered.

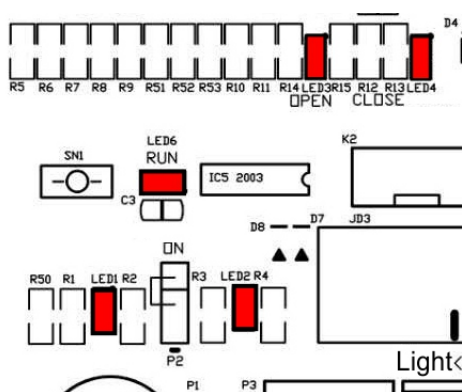

- OPEN (LED3):** Illuminated when the gate is travelling in the opening direction.
- CLOSE (LED4):** Illuminated when the gate is travelling in the closing direction.

RUN (LED6):

- Blink 1 time per second:* Gate motor is running in open direction.
- Blink 2 time per second:* Gate motor is running in close direction.

LED Blinking whilst open: Will blink once per second when the gate is in the open position counting down the auto close timer.

LED1: OPEN position limit switch status.

- LED ON:* Open limit switch has been triggered.
- LED OFF:* Open limit switch has not been triggered.

LED2: CLOSE position limit switch status.

- LED ON:* Close limit switch has been triggered.
- LED OFF:* Close limit switch has not been triggered.

Logic DIP Switch Adjustment

DIP 1 (Multi Key/Single Key)

Note 1: If DIP 1 is ON the button used for pairing will perform the open/stop/close function

Note 2: Lock/Unlock function is invalid when DIP 1 and DIP 2 are OFF

Please see Wireless learning page for keypad operation

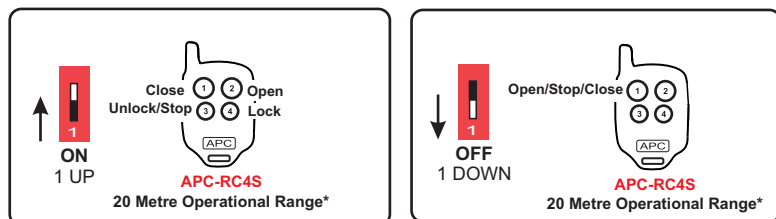

DIP 2 (Lockout Function)

The lockout function is used for security applications to lockout the system from operation. It can only be enabled and disabled using a remote button 3 (unlock) & button 4 (lock) on the remote whilst in multi key mode.

Note: If the system is in the locked state it will lock all wired access control along with all wireless.



DIP 3 (Automatic Close)

The Automatic Close Dip switch is used to enable/disable the auto close feature. To set or adjust the auto close feature please see auto close adjustment.

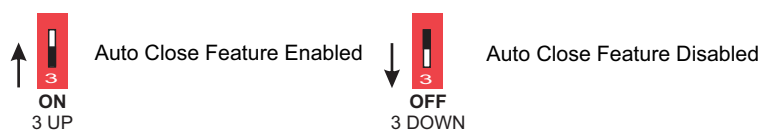

DIP 4 (Ramp Function)

The RAMP feature is used to slow start smaller capacity motors. It can be adjusted when enabled using the FORCE potentiometer. Please see Ramp Configuration for further information.



DIP 5 (Reverse Function)

The Reverse feature is used to set the system to revert back to the OPEN direction if it encounters an obstacle when closing. This feature sensitivity is configured using the TORQUE potentiometer.



DIP 6 (Program State)

When enabled the board will be ready to learn the motor protection time or the auto close time depending on the settings. Please see further information on auto close adjustment and learn time adjustment.



Setting the motor protection time

Before beginning this step you must first ensure that all your motor wiring connections and the direction switch are all set correctly, there are no loose wire strands and all connection points are joined and insulated correctly.

This feature is used to set the maximum running time of the motor in case of an emergency which would cause the operator to run continuously or if the gate motor were left in a manual override and was triggered by a user to operate.

The maximum possible motor protection time is 90 seconds.

Check your Striker Plates or Magnet positions!

Preliminary checks prior to protection time program

Ensure gear rack is not binding with **ZERO** resistance

Ensure gate is free of **ALL** bowing

Ensure that the motor is firmly fixed

Ensure that the connections are all correct with no loose wire strands

Ensure that limit switch strikers are set correctly

GATE MUST BE CLOSED BEFORE BEGINNING THE STEPS BELOW

1

Turn DIP 6 to the ON position.



2

Press and **HOLD** the "F" Button, you will hear a "Bi" from the buzzer.

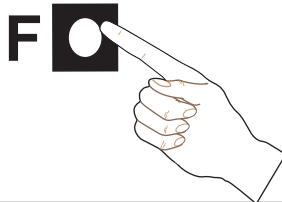

3

Release the F button **IMMEDIATELY** after the gate begins the opening movement.

4



The gate will open to the open position striker plate then the buzzer will make a "Bi" sound.

Now the gate automatically start closing.

5



Once the gate reaches the closed position striker plate then the buzzer will make a "Bi" sound.

6

Turn DIP 6 to the OFF position.

Protection time learning is complete.



Setting the Automatic Close Timer

1 Turn DIP 3 and DIP 6 to the ON position.

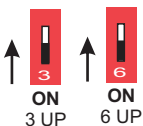

2 Press and release the "F" Button to the same amount of seconds you wish the auto close time to be will hear a "Bi" from the buzzer.

Example: Press the "F" button 30 times for 30 seconds.
Maximum auto close time is 60 seconds.

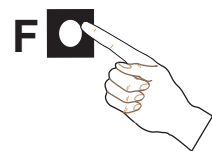

3

Turn DIP 6 **ONLY** to the OFF position.

Auto Close time learning is complete.



Remote and Wireless Equipment Pairing

Pairing APC Remote's

The original remote's supplied with the sliding gate opener system are already paired.

- Press the small STUDY button for ONE SECOND then release.
- Press the NUMBER 1 button on the remote for 1 second.
- Press the remote button to test operation.

Pairing APC Wireless Push Buttons

Ensure the switch is in the ON state using the supplied key

- Press the small STUDY button for ONE SECOND then release.
- Press the wireless push button for 1 second.
- Press the button to test operation.

Pairing APC Wireless Keypads

Use the default pin codes, after successful pairing then you can change the pin numbers

- Press the small STUDY button for ONE SECOND then release..
- Type 1 1 1 1 #
- Type 1 1 1 1 # again to test operation.

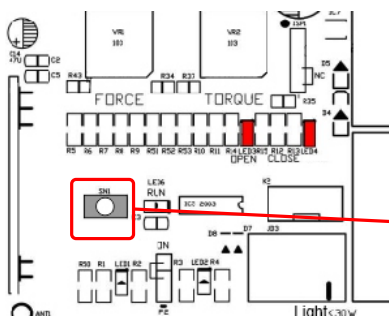

1
Press this STUDY
button for ONE SECOND

2
Press the button on the remote button you wish to use for 1 second.
OR
Press the Wireless Push button.
OR
Type in the pin code on the Wireless Keypad.

Clearing the memory (Formatting)

- Press and hold the STUDY button for 5 seconds and a small BEEP will be heard. Release the STUDY button and all wireless equipment will be deleted.

Connecting a Single PE Sensor (APC-PE-2000)

APC-PE-2000 PE sensor (Transmitter & Receiver) **must be connected back to the control board**.
Install the PE-2000 Photoelectric sensor on the first entry point of the driveway from post to post at approx. 500mm above ground level.

The Transmitter and the Receiver must be inline with each other
(The inline LED will be off when aligned with the transmitter).

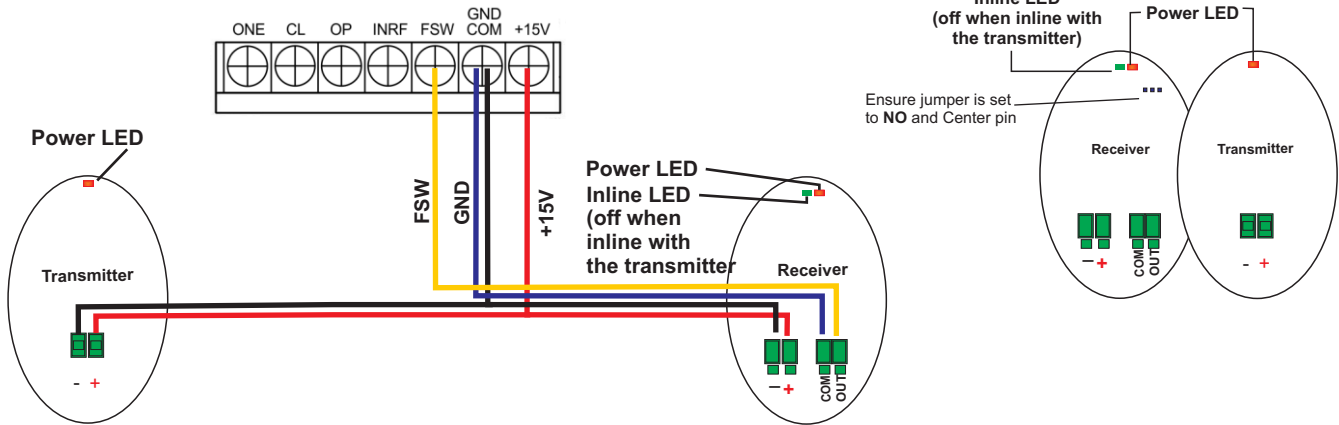

Connecting a Single Retro Reflective Sensor (APC-RR-11)

APC-RR-11 Reflective sensor (Transmitter only) **must be connected back to the control board** (see wiring diagram).
Install the RR-11 Reflective sensor on the first entry point of the driveway from post to post at approx. 500mm above ground level.

The Transmitter and the Reflector must be inline with each other
(The yellow inline LED will be ON when Aligned with the transmitter).

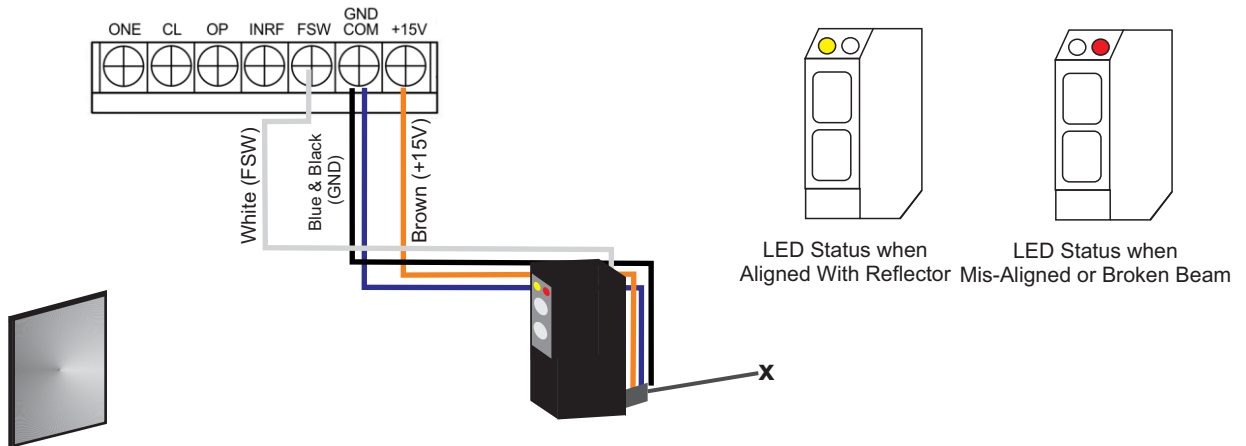

Connecting an APC Keypad (APC-KP1-C)

Unlike a push button entry switch using a keypad can provide a much higher security for access control for guests, workers, tenants etc.

Using a keypad will allow you to manage the users by adding and deleting as required. Its backlit illumination also allows for ease of use at night.

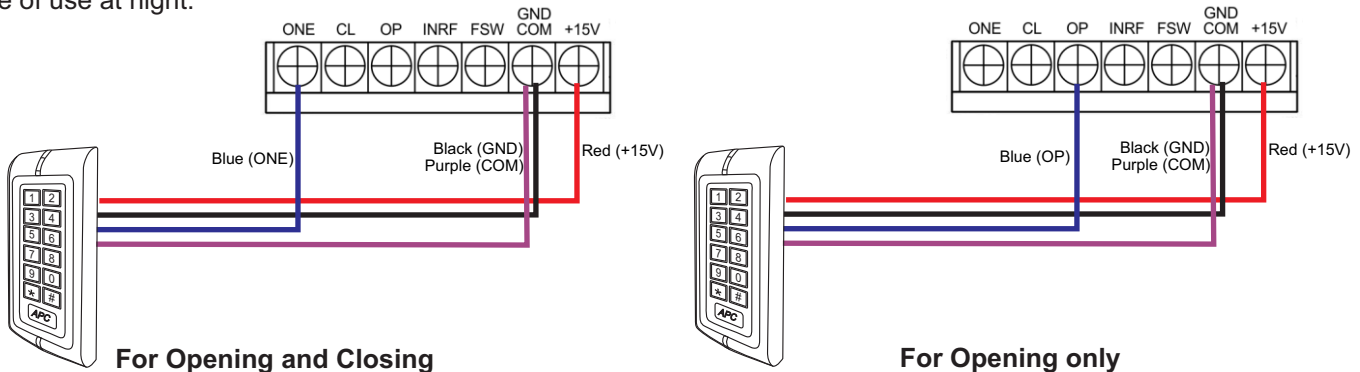

APC GSM Receiver

A GSM Receiver is the absolute most flexible form of access control. Providing there is good mobile reception at the gate the GSM switch can operate the gate from anywhere in the world. When receiving a call it will automatically reject the call and open or close the gate. SIM CARD IS NOT SUPPLIED.

APC-GSM-CH1-3G

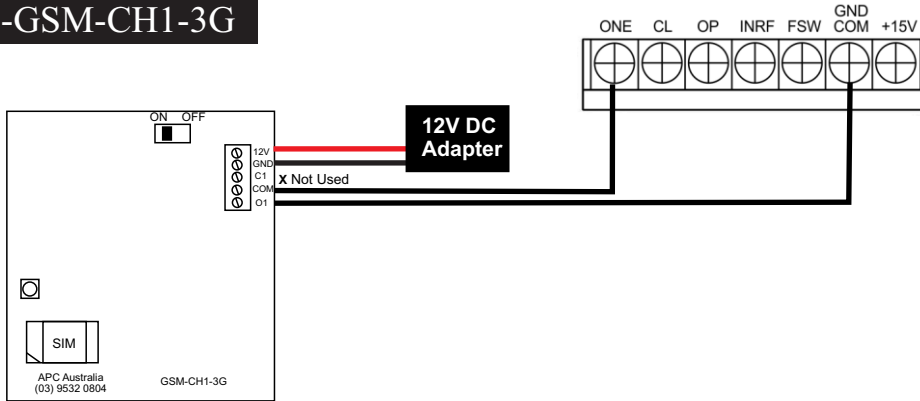

APC-GSM-CH2-3G

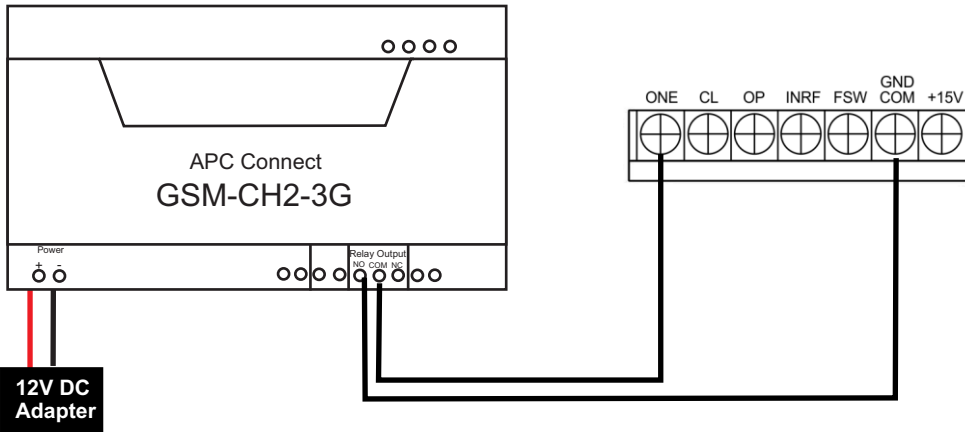

APC Wired Push Button Connection

Push buttons are used for opening and closing the gates without using a remote. Push buttons can be used for a vast amount of purposes ranging from basic access control for visitors, workers to taking out the bins.

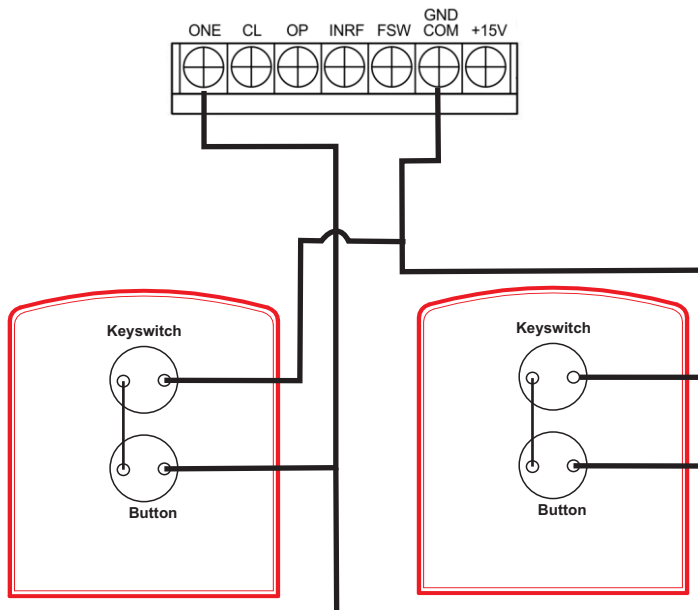

Eyevision® 4 Wire Intercom System Connection

Door Station Model: EV-295

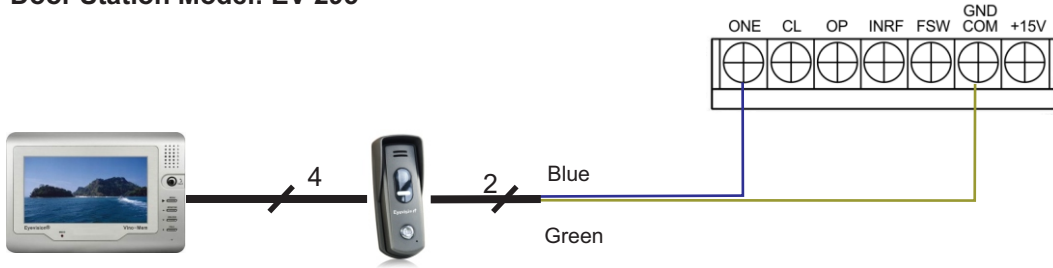

Door Station Model: EV-291

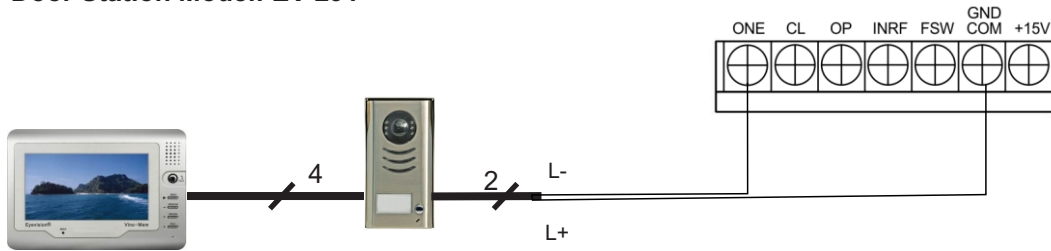

Eyevision® 2 Wire Intercom System Connection

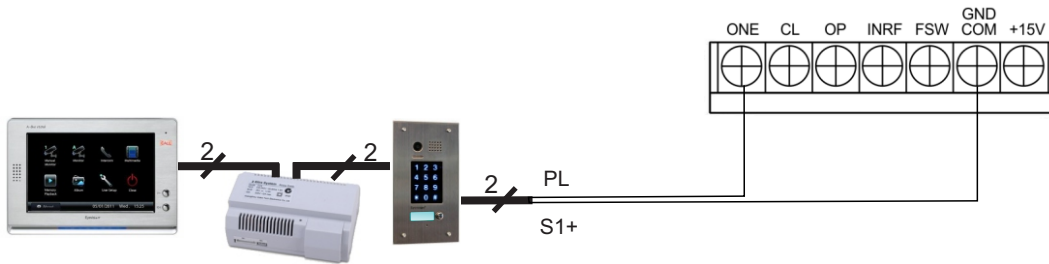

Eyevision® 4 Wire HYBRID Intercom and WIFI intercom System Connection

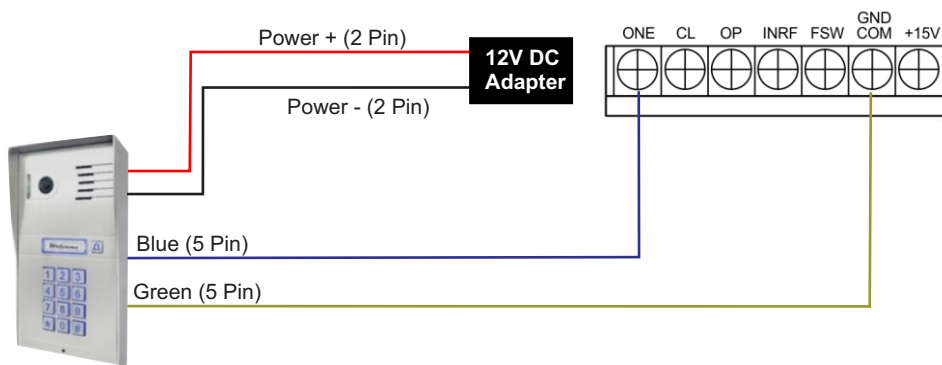

APC Loop Detector for Auto Gate Opening

The APC-LD1 can be used for automatic opening when it senses a vehicle. It must be used in conjunction with the specific loop detector wire.

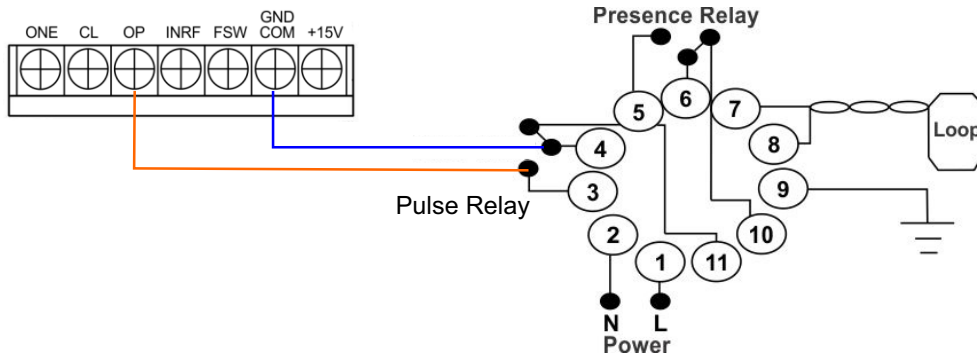

A PE sensor setup set MUST be used in this application.

APC Loop Detector as a safety device

The APC-LD1 can be used for closing prevention whilst a vehicle is in the general gate area. It must be used in conjunction with the specific loop detector wire.

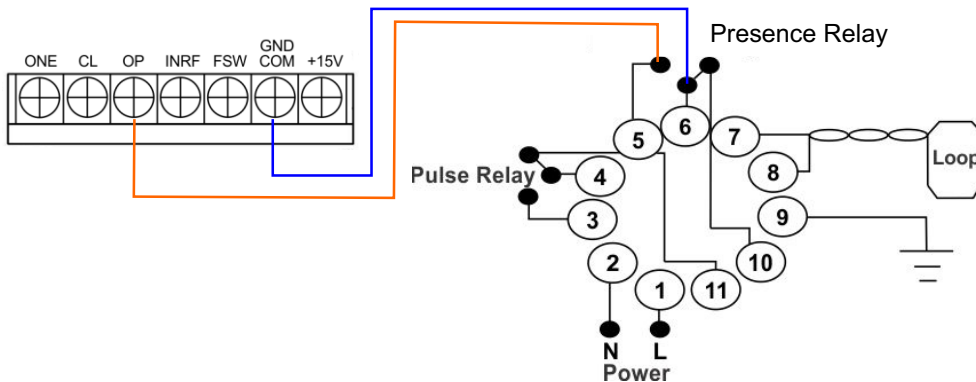

Connecting a 240V Light

The light output on the system will operate whilst the gate is OPENING and whilst the gate is CLOSING. Whilst open the light output is in the OFF state.

The maximum load on this circuit should be no greater than 30 Watts, When using a higher load please use an external relay suited to the load requirements.

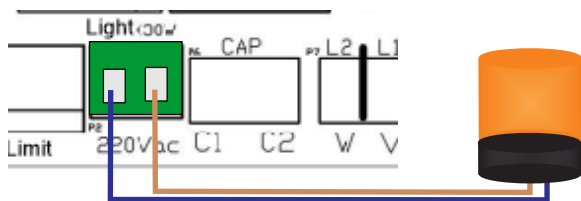

240V Lamp 30W Maximum

Compatible Equipment

The equipment listed below does not affect the warranty of the control panel and have been tested and approved for use. Limited warranty is applied to the control panel when used with third party equipment.

Sensors

- APC-PE2000
- APC-RR-11

Keypads

- APC-KP1-C
- APC-KP1-D
- APC-KP2W

Push Buttons

- APC-PBS (K/W/K/KW)
- APC-PBD (K/W/K/KW)
- APC-PBD211
- APC-PBD164

Remotes

- APC-RC4 (BK/SS/BK-S)
- APC-RC400 & RC400S
- APC-RC200

Loop Detector

- APC-LD1

Receivers

- APC-GSM-CH1-3G
- APC-GSM-CH2-3G
- APC-RCR2

MAINTENANCE

1. The rack and drive gear should be kept clean. Do not attach any objects to the gate that may interfere with the rack or drive gear.
2. The limiting levers should be kept free of debris.
3. Lubricate all moving parts every 3 months.
4. Check power cables and conduit have not been damaged.
5. During heavy rainfall or light flooding ensure the motor housing has had no ingress of water.

TROUBLE SHOOTING

Problem	Possible cause	Repair method
Gate fails to open	1- Clutch door may be open and the clutch is disengaged	Close the clutch door and turn the key
	2- No power to the control board or motor	Check the fuse and the mains switch to restore power
	3- Fuse may be blown	
	4- Remote control may be faulty or damaged or has a dead battery	Replace the remote battery
	5- Damaged power cable	Replace
	6- Control board may be faulty or damaged	Test, repair or replace
The remote working distance reduced	1- Low battery	Replace battery
	2- Interference for other equipment using the same frequency	Delete remote and re- programme
Gate fails to stop at the start or the end	The terminal stop toggle switch is damaged or obstructed	Replace toggle switch or remove obstacle
When pressing the remote the motor is running but the gate is not moving	1- The motor drive gear is disengaged from the rack (the gate may have opened or closed to far)	Check toggle switch operation and replace if nessasry
	2- Gate has lifted of the track and disengaged the rack	Remove debris from the track and/or refit the gate on the track
The motor fails to run after the remote control button is pressed	1- The resistance sensitivity is set too high	Rest resistance sensitivity
	2- The gate is jammed with some obstacle	Open clutch door, remove obstacle, close the clutch door



APC WARRANTY

APC warrants the original purchasers or the APC gate(s) opening system for a period of twelve months from the date of purchase (not installation), the product shall be free of defects in materials and workmanship under normal use. During the warranty period, APC shall, as its option, repair or replace any defective product upon return of the product to its factory, at no charge for labour and materials.

Any replacement and/or repaired parts are warranted for the remainder of the original warranty,

The original owner must promptly notify APC in writing that there is defect in material or workmanship, such written notice must be received in all events prior to expiration of the warranty.

International Warranty

APC shall not be responsible for any freight fees, taxes or customs fees.

Warranty Procedure

To obtain service under this warranty, AND AFTER CONTACTING APC, please return the item(s) in question to the point of purchase.

All authorized distributors and dealers have a warranty program, anyone returning goods to APC must first obtain an authorization number. APC will not accept any shipment for which prior authorization has not been used.

Conditions to Void Warranty

This warranty applies only to defects in pairs and workmanship relating to normal use. It does not cover:

- Damage incurred in shipping or handling
- Damage caused by disaster such as fire, flood, wind, earthquake or lightning
- Damage due to causes beyond the control of APC such as excessive voltage, mechanical shock or water damage
- Damage caused by unauthorized attachment, alterations, modifications, or foreign objects.
- Damage caused by peripherals (unless such peripherals were supplied by APC)
- Defects caused by failure to provide a suitable installation environment for the products
- Damage caused by usage of the products for purpose other than those for which it was designed.
- Damage from improper maintenance
- Damage arising out of any other abuse, mishandling, and improper application of the products.

Under no circumstances shall APC be liable for any special, incidental, or consequential damages based upon breach of warranty, breach of contract, negligence, strict liability, or any other legal theory. Such damages include, loss of profits, loss of the product or any associated equipment, cost of capital, cost of substitute or replacement equipment, facilities or services, down time, purchaser's time, the claims of third parties, including customers, and injury to property.

Disclaimer of Warranties

This warranty contains the entire warranty and shall be in lieu of any and all other warranties, whether expressed or implied (including all implied warranties of merchantability or fitness for a particular purpose). And of all other obligations or purporting to act on its behalf to modify or to change this warranty, nor to assume for it any other warranty or liability concerning this product.

Out of Warranty Repairs

APC will at its option repair or replace out-of-warranty products which are returned to its factory according to the following conditions. Anyone returning goods to APC must first obtain an authorization number.

APC will not accept any shipment whatsoever for which prior authorization has not been obtained. Products which APC determines to be repairable will be repaired and returned. A set fee which APC has been predetermined and which may be revised from time to time will be charged for each unit repaired. Products which APC determines not repairable will be replaced by the nearest equivalent product available at that time. The current market price for the replacement product will be charged for each replacement unit.