



APC-SG24W-E Flood Proof Sliding Gate System



Attention Installer

The manual should be read cover to cover at least once prior to beginning installation

It is absolutely critical to set the operating direction (Left/Right) and the magnet positions PRIOR to operating the system

Congratulations on the purchase of your APC Automation Systems ® Gate Automation Kit.

For your convenience any Remote's and wireless buttons supplied with the kit are already paired with the system.

Page 1

Preliminary Checks
Safety Information
Motor Specifications
Control Board Features

Page 2

Installation Layout

Page 3

Motor and Base Plate Dimensions
Conduit Placement for Gate Motor
Fixing of the Control Box

Page 4

Tools Required
Standard Motor Kit Contents
Emergency Override/Clutch Override

Page 5

Motor and Gear Rack Installation

Page 6

Magnet Installation

Page 7

Control Board Quick Reference Guide
Onboard Buzzer

Page 8

Phoenix Connectors and Wiring Termination
Successful Setup Flowchart

Page 9

Gate Motor Connection to Control Board

Page 10

ON/OFF Switch
Transformer Connection
Lengthening the External Transformer

Page 11

Solar Panel and Bracket Assembly
Solar Panel Connection

Page 12

Battery Connection

Page 13

Motor Speed Adjustment
Enable/Disable the Slowdown
Auto Close Adjustment
Over Current Sensing Adjustment

Page 14

Smart Receiver Configuration
Pairing Remote's, Wireless Push Buttons and Wireless Keypads

Page 15

Using Wireless Equipment
Party Mode
Wireless Push Button Configuration
Wireless Keypad Programming

Page 16

GSM Connection
Keypad Connection
Wired Keypad Programming

Page 17

Wired Push Button Connection

Page 18

SETUP Cycle

Page 19

Loop Detector Connection
Intercom Connection

Page 20

Photoelectric Sensor Connection
Retro Reflective Sensor Connection

Page 21

Courtesy Light Connection
External Antenna Connection
Compatible Equipment

Page 22

Troubleshooting

Attention Installer

There is no substitute to the benefits of reading and understanding the manual

The warranty covers faulty products only and not problems or damage caused by the installer

Pictures of the installation are always requested for troubleshooting or technical support

*As an installer or DIY you have undertaken the responsibility to install this automation system
It is of utmost importance to read the instruction manual and understand it before proceeding.
If in doubt after reading please call us and ask questions before proceeding.*

In addition to the above the following must be observed to make the installation process

1

The remote controls combined in this kit are already paired into the system. If Wireless buttons have also been purchased together with the kit then they have also been paired into the system.

2

This Gate automation control panel has been tested and pre-configured with the factory default setting. This means that the automation kit will work correctly for most size and weight gates with only the Setup procedure. A small adjustment to the over current setting may be required for your gates.

DO NOT ADJUST OVER CURRENT SENSING UNTIL ALL SETUP AND TROUBLESHOOTING PROCEDURES HAVE BEEN USED

* See REF1 & REF2 in the control panel settings

3

Motor(s) test and magnet setup must be carried out according to the description in the motor section of the manual prior to connection to the control panel. Failure to do so will result in damage to the control panel.

4

The M output on the control board is voltage OUT and NOT VOLTAGE IN, **DO NOT** connect a power source to this output. Doing so will immediately burn the control board.

5

M Output has LED indicators (Green for Opening and Red for Closing) The LED's are above the output it is of utmost importance that you must be aware of the following:

- A. Observe the colours sequence during the cycles (Green while Opening and Red while Closing)
- B. The LED's must switch off within 3 seconds once the gate(s) reach the full open or full close

6

The battery/batteries system must be connected correctly and according to the manual to avoid damaging the control board, incorrectly connecting the batteries will result in damage to the control board.

Preliminary Checks

To ensure safety and an efficient automation make sure the following requirements are met:

1. The gate structure must be suitable for automation.
2. Make sure that the gate move properly and uniformly without any irregular friction during their entire travel.
3. The gates wheels and track must be in good condition with no biting, no rust and must be well greased.
4. The gates should be able to be freely opened and closed before installing the gates automation system.
5. It is strongly suggested to have a gate stop installed for the open position for setup and emergency purposes.

Important Safety Information

Installer and owners should observe the following:

1. Make sure that there is sufficient space for the gate to slide open fully without interference.
2. The control Panel Box must be installed in the area within 9 meters maximum cable distance from motor.
3. Do not change with parts or components not supplied by the manufacturer, this includes sensors, buttons, solar panels, transformers and any component not listed in the compatibility list.
4. Make sure all wiring works are correct and in good condition before connecting the battery, solar panel or transformer to the control panel.
5. Turn off the power and disconnect the battery when doing any maintenance.
6. Ensure the control panel box is free from water leakage to avoid short circuiting of the control panel.
7. Do not supply mains power directly to the motor, control box or any accessories.
8. Do not install the operating system if in doubt. Contact the manufacturer.
9. Do not cross the gate while it is operating, Safety sensors are only to prevent accidents or injuries.
10. Keep the remote controls in safe place and away from children.

Before beginning installation the manual should be read thoroughly concerning all aspects of the installation including all precautions and safety information.

Proper steps should be taken to ensure efficient and safe installation for vehicles, property and persons within the operators working radius.

The system is fitted with an over current sensing feature to assist in preventing damages, injuries and death. All precautions must be taken by the installer that adjustments are set correct based on the gates weight, height and length. The system sensitivity should be set to allow consistent operation of the gates under normal operating conditions. This does not include operating against wind. The system may not detect (Over current sense) against light loads such as small object, young children and animals. It is the operators duty to ensure that the area is clear prior to operation. Photo sensors or Reflective sensors should always be installed to assist in accident or death prevention. Rubber edging should be installed onto the gates to assist in dampening any accidents or damages.

You agree to install this product following any and all safety requirements listed in this manual or required under local, state or national regulations. APC Automation Systems, its distributors, stockist or sellers are not liable for any direct, indirect, incidental, special or consequential damages or loss of profit wether based in contract or any other legal theory during the course of warranty or afterwards. If you do not feel capable of properly installing the operator based on the above information or otherwise do not proceed.

Motor Specifications

IP Rating	IP57
Voltage	24V DC
Power	80W
Maximum Thrust	360N
Motor Speed	1800RPM
Operating Temperature	-20° ~ 55°C

Control Panel Features

Over Current Sensitivity
Built in Solar Regulator
Battery Undercharge Safety Cut Off
Remote and Wireless Button Compatibility
Automatic Close
Party Mode (Cancel Auto Close)
Dedicated Safety (PE) Sensor Output
Dedicated constant 24v Output
Loop/Exit Wand Input
Input for Push Button, keypad, fingerprint reader and other access control compatibility
Courtesy Lamp Output

Installation Layout

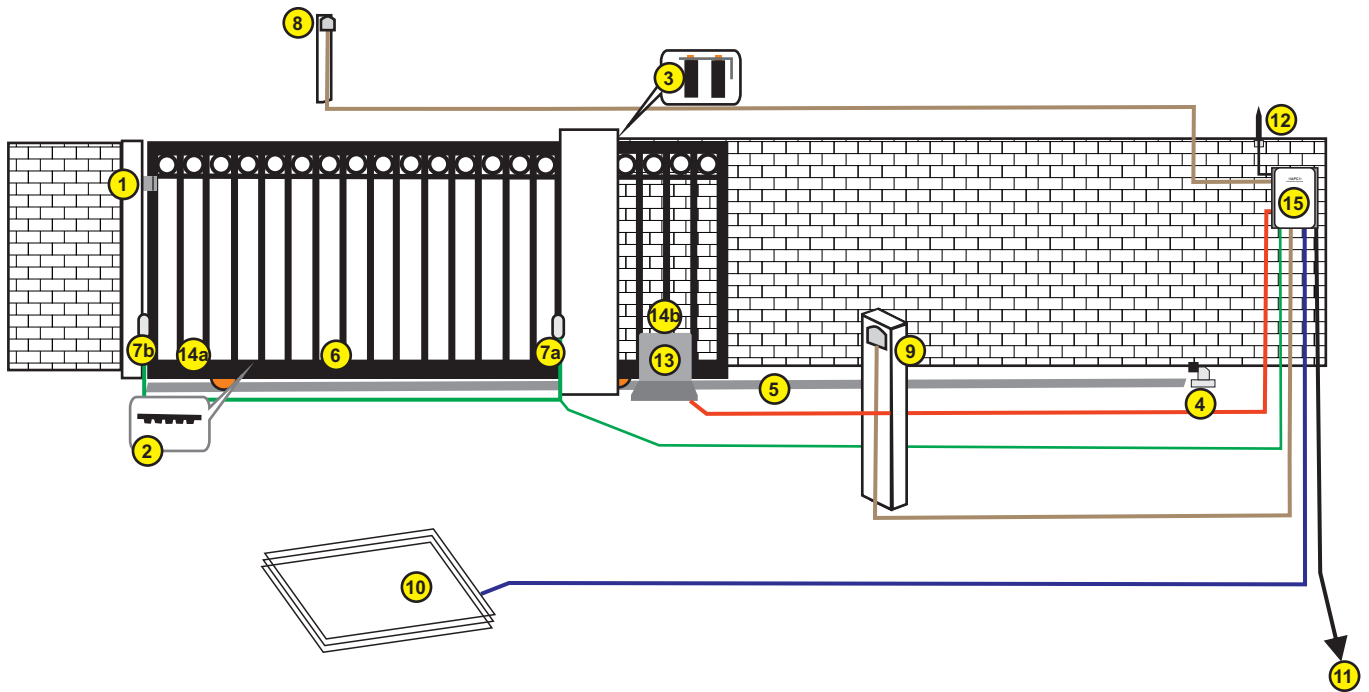
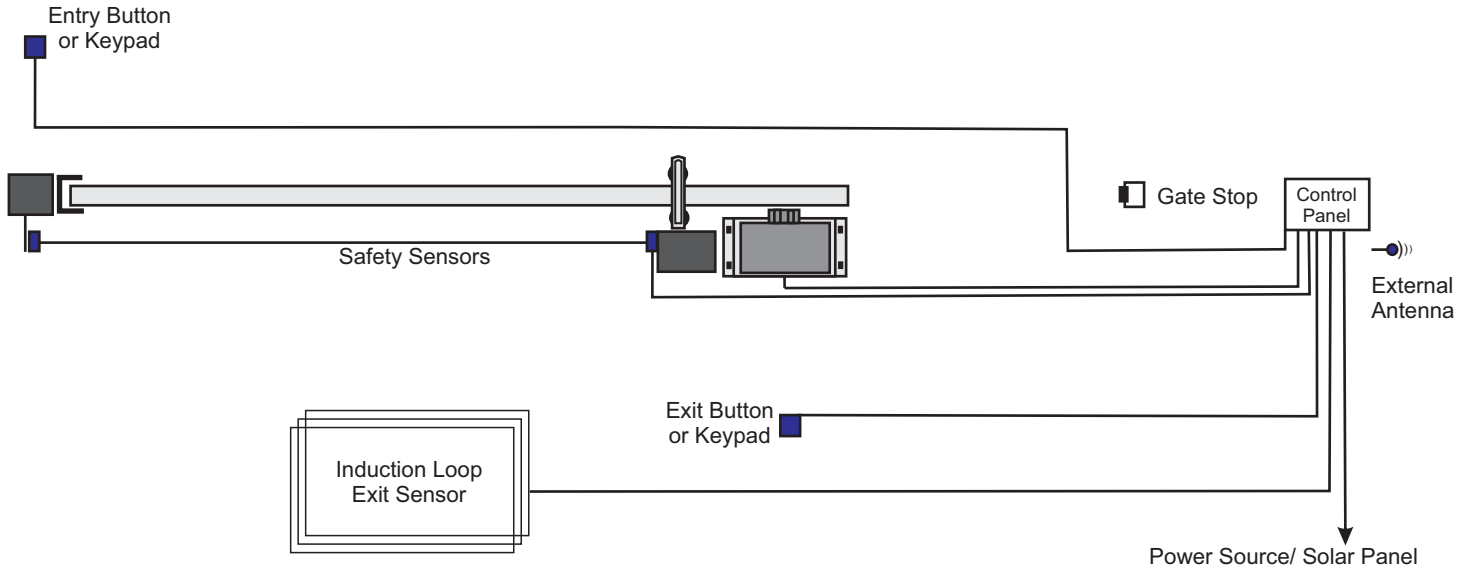

1	U Guide/Keep
2	Wheels
3	Rollers and Bracket
4	Gate Stop
5	Floor Track
6	Gear Rack
7a	PE Sensor Transmitter
7b	PE Sensor Receiver (Not required for Retro Reflective Sensor)
8	Entry Keypad/Push Button
9	Exit Keypad/Push Button
10	Induction Loop Exit Sensor
11	Power Source (Mains/Low Voltage or Solar Panel)
12	External Antenna
13	Gate Motor
14a	Open Magnet
14b	Close Magnet
15	Control Box

Requiring Wiring:

Keypad - 4 Core (Wireless available)
 PBD-K - 4 Core (Wireless available)
 PBS-K - 2 Core (Wireless available)
 PE Sensor
 Receiver - 4 Core
 Transmitter - 2 Core

Induction Loop 1 Core Teflon Cable
 Motor 2 Core 2mm or Greater

Motor And Base Plate Dimensions

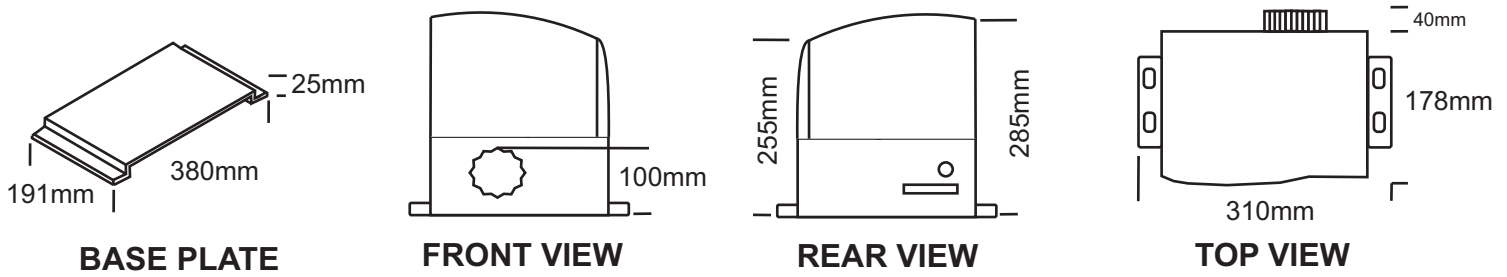

Conduit placement for Gate Motor

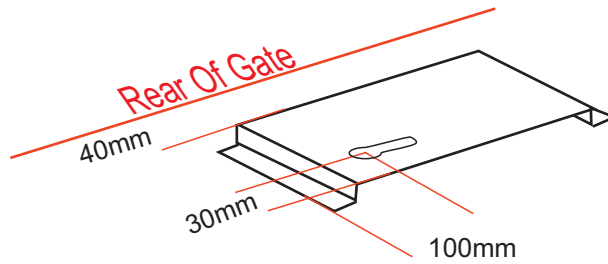

Fixing the Control Box

The supplied fixing screws and wall plugs are for Masonry fixing. When fixing to other surfaces use the appropriate fasteners.

Eg. For metal surfaces use Tek Screws and for Timber fixing use timber screws.

1. Install the corner tabs supplied with your kit to the rear of the control box using the 10mm Pan head screws.
2. Choose a location in which to mount the control box. The control box must be kept within 9 metres away from the motor(s) in cabling distance and a minimum of 1m height from the ground.
3. Mark the fixing points of the control box on the mounting surface whilst the box is held perfectly level. A bubble level is ideal to assist in keeping the box level.
4. If fixing to a masonry surface use a 6mm masonry drill bit to drill the fixing points for the wall plugs.
5. Gently tap the wall plugs into place until they are flush with the fixing surface.
6. Hold the control box in place whilst aligning the holes of the corner tabs with the wall plugs then fix into place using the 38mm pan head screws.
7. Apply LIGHT tension to the top of the control box to ensure that it is secured in place.

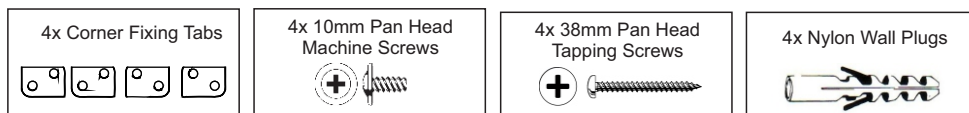
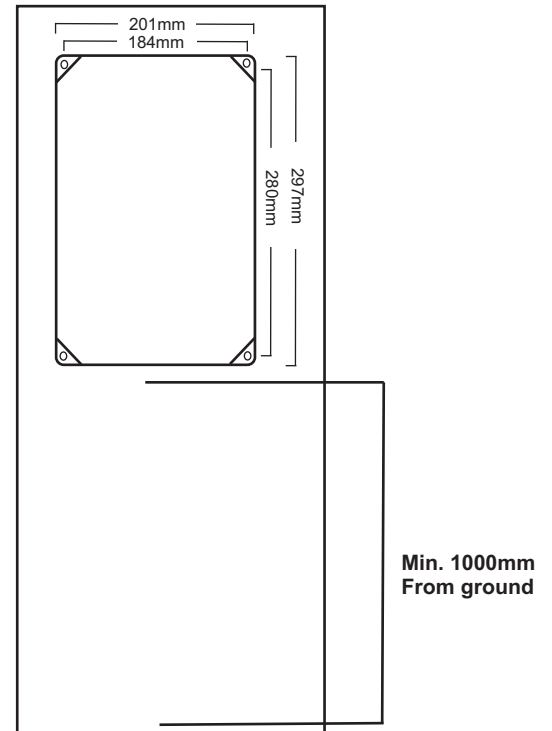

Tools Required

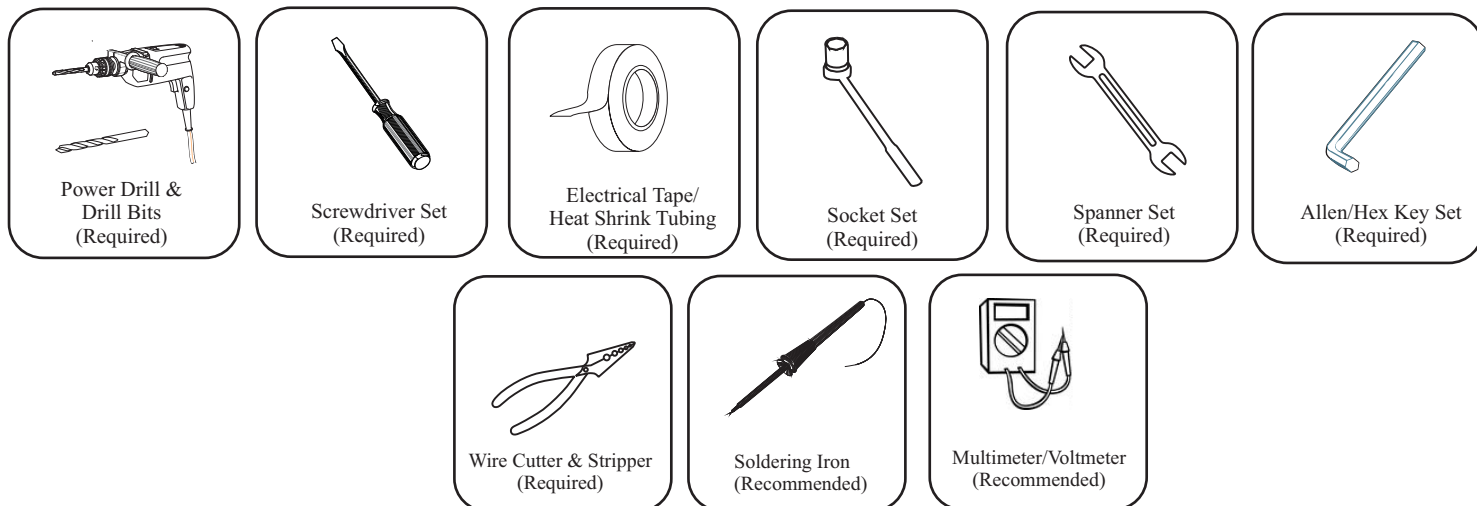

Standard Motor Kit Contents

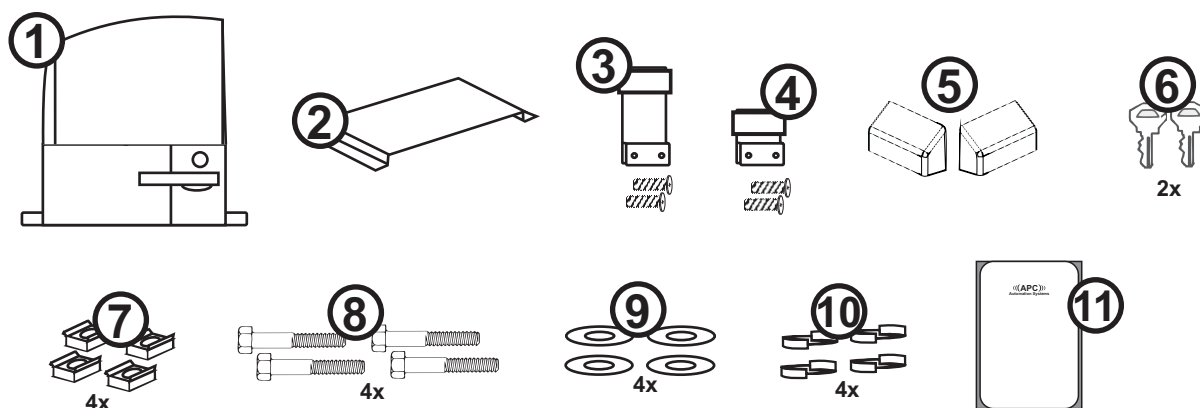

1. Sliding Gate Motor Assembly with 6m cable
2. Sliding Gate Motor Base Plate
3. Open Position Magnet, Bracket and fixing screws
4. Closed Position Magnet, Bracket and fixing screws
5. Side Covers
6. Override Keys
7. Nutclips
8. Fitting Bolts
9. Washers
10. Spring Washers
11. Control Box & Fixing Hardware

Emergency Override/Clutch Override

To override the motor insert the key into the barrel located on the rear and turn clockwise then pull the lever to 90°.

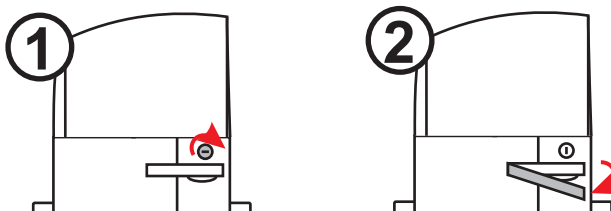

1 Fit the 4x Clip Nuts to the back (bottom) of the motor base plate.

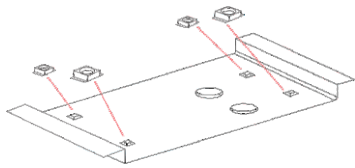

2 Feed the conduit through the base plate.

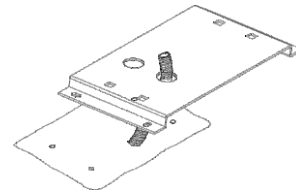

3 Fit the motor base plate to the concrete pad 40mm away from the gate using dyna bolts.

NOTE: Ensure motor base plate is level, if not make the necessary adjustments to rectify.

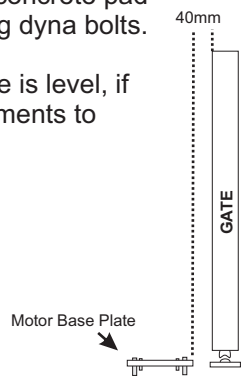

4 Fit motor cable through the base plate then through glands and tighten ALL the glands to create a flood proof seal. Skipping this step or not tightening enough will not allow for the flood proof feature of this system.

Note: Excess cable slack will be required

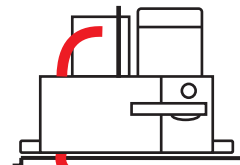

5 Fit the motor to the base plate using the 4x bolts and washers supplied. The bolts will tighten to the nut clips fitted in step 1.

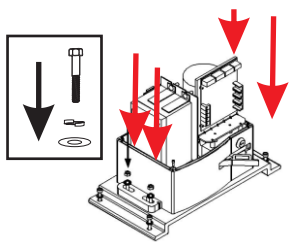

6 Slide the side covers into place to cover the fixing bolts of the motor to base plate.

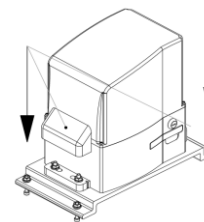

7 Install the gear rack onto the gate.

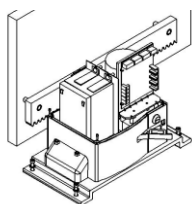

The best method for installation is to have the gate closed, sit the first piece on the pinion of the motor then fix directly to the gate in the center of the fixing hole (make sure it is 100% level first).

Now loosen the fixing and adjust the spacing between the motors pinion and the gear rack (as illustrated) then re-tighten. Each piece of gear rack will clip into the previous piece and providing you use a level minimal adjustments will be required afterwards.

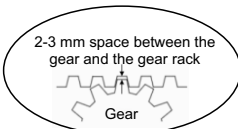

You can use the clutch feature of the motor to open and close the gate whilst the gear rack is fitted.

8 **DO NOT SKIP THIS STEP**

Test the gear rack installation by setting the motor to manual override.

To override the motor insert the key into the barrel located on the rear and turn clockwise then pull the lever to 90°.

Now very slowly pull the gate open and closed, you will find tight and loose points in the gearing. These must now be rectified by loosening the fixing screws and adjusting the gear rack up/down until the gate is 100% consistent.

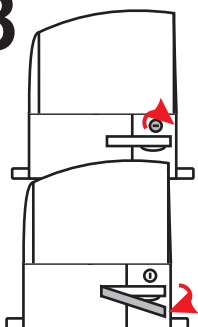

9

IMPORTANT! IMPORTANT! IMPORTANT!

Setting the magnet placement

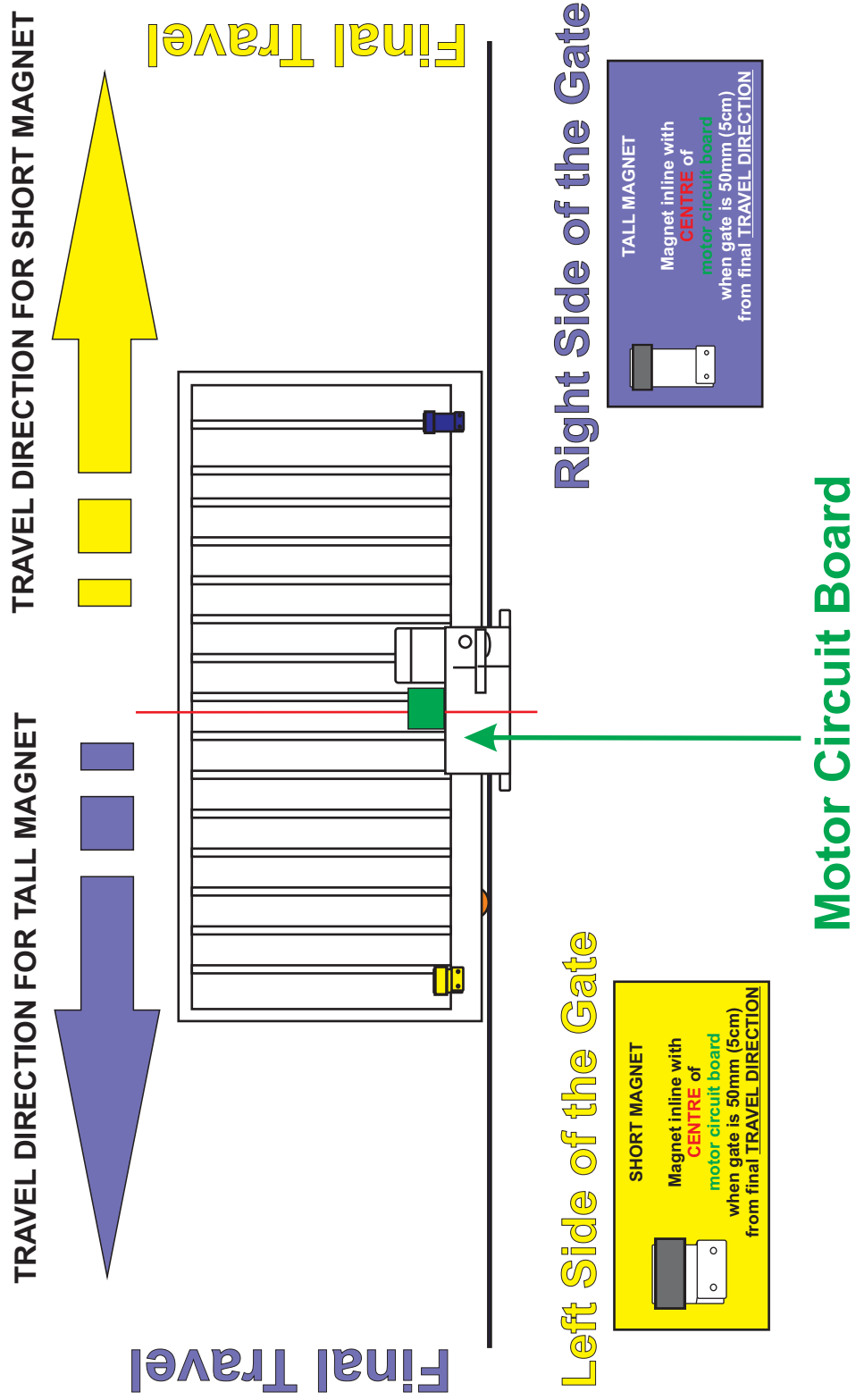

Quick Reference Guide

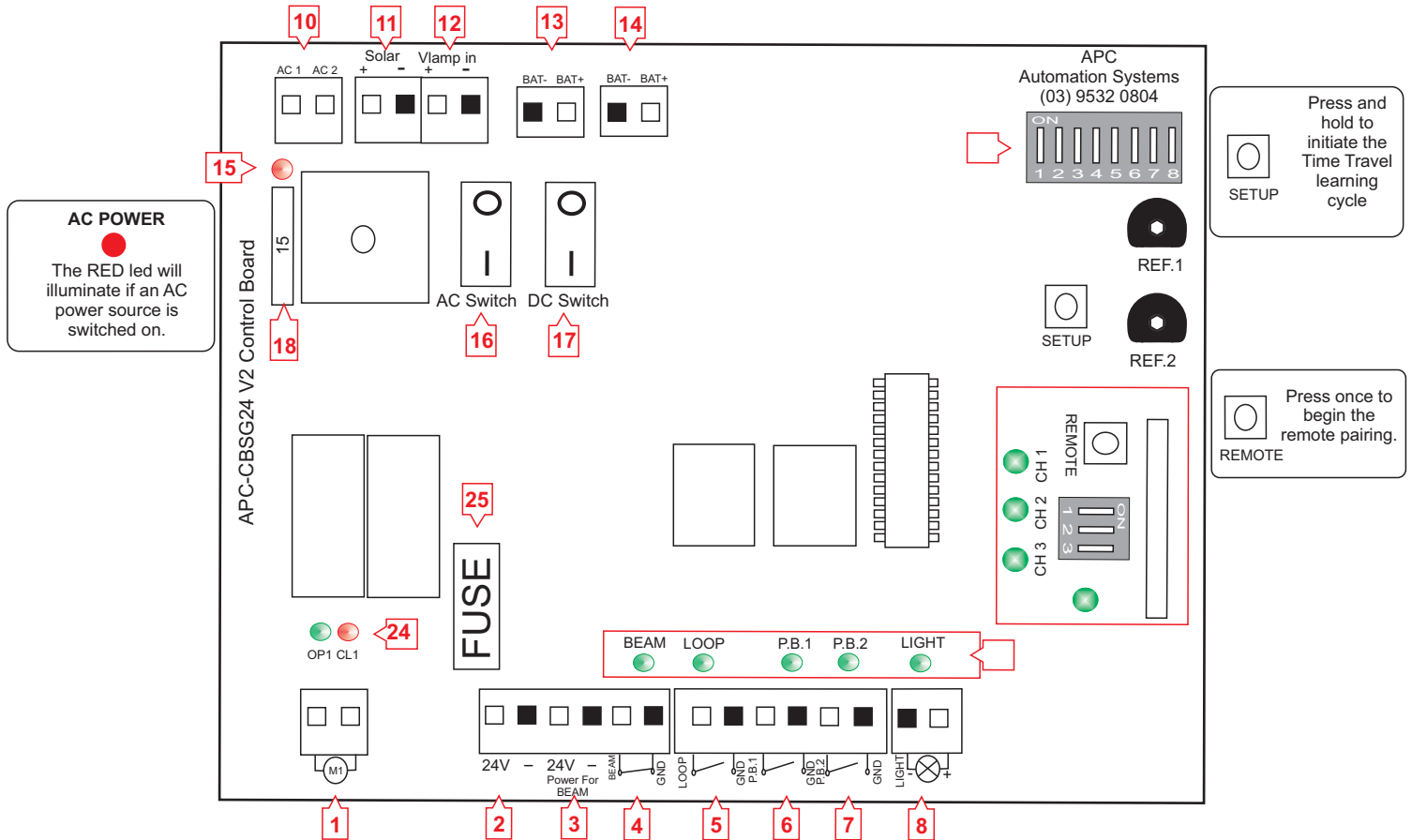

AC POWER
 The RED led will illuminate if an AC power source is switched on.

Press and hold to initiate the Time Travel learning cycle
 SETUP

Press once to begin the remote pairing.
 REMOTE

The Green LED will be ON during the Opening cycle of M1 Motor Output
OP1

The Red LED will be ON during the Closing cycle of M1 Motor Output
CL1

1. Motor Output
2. Constant 24V DC output
3. PE Sensor 24V DC output
4. PE Sensor Input
5. Loop Input
6. Pedestrian Opening Push Button Input
7. Full Gate Opening Push Button Input
8. Light Output
9. 433MHZ Antenna
10. AC Input
11. Solar Input
12. Light Voltage Input
13. Battery Input
14. Second Battery Input (Solar)
15. AC Power LED
16. AC Switch
17. DC Switch
18. AC Fuse
19. Speed, Slowdown & Autoclose Configuration
20. REF 1 & REF 2 Sensitivity Adjustments
21. Time Travel Setup
22. Remote Configuration/Programming/Status
23. Accessories Status indicators
24. Motor Output Status Indicators
25. Accessories Output Fuse

CH 1: Full Gate Channel: Illuminated whilst CH1 Button is pressed on Controller Or PB2 Circuit is activated
CH1

CH 2: Pedestrian Opening Gate Channel: Illuminated whilst CH2 Button is pressed on a Controller Or PB1 Circuit is activated
CH2

CH 3: Cancel Auto Close Channel (Party Mode): Illuminated whilst CH3 Button is pressed on a controller
CH3

Beam The GREEN LED is OFF in Standby & Opening It will be ON during the closing cycle to indicate that the safety beam circuit is operational and not Interrupted .

Loop The GREEN LED will pulse ON once when receiving contact indicating that the signal was received.

PB 1 The GREEN LED will pulse ON once when receiving contact indicating that the signal was received.

PB 2 The GREEN LED will pulse ON once when receiving contact indicating that the signal was received.

ONLY VALID IF VLAMP 24V DC SUPPLY IS CONNECTED
Light This GREEN LED will be ON during the opening and closing operation of the gate. It will stay ON while the gate is open and it will switch OFF after the gate(s) are closed. Party Mode will also turn off the output.

Onboard Status Buzzer

Di Di	Autoclose
Di Di Beep	Overcurrent Sensing
Beep Beep Beep	Battery Error (Less than 21V)

Phoenix Connectors and Wiring Termination

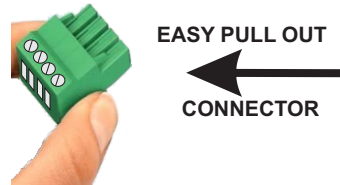

All Connectors are Pull-Out Connectors for ease of installation.

1. Remove Connector from Control Board.
2. Use a Flat head screw driver to loosen the top screw which will open the clamp point.
3. The casing should be stripped to expose ~12mm of the conductor. The conductor should be then folded back to leave a length of ~7-8mm. This method will allow the conductor to have maximum hold whilst in the connector.



4. Tighten the screw CLOCKWISE to clamp.

Successful SETUP flowchart

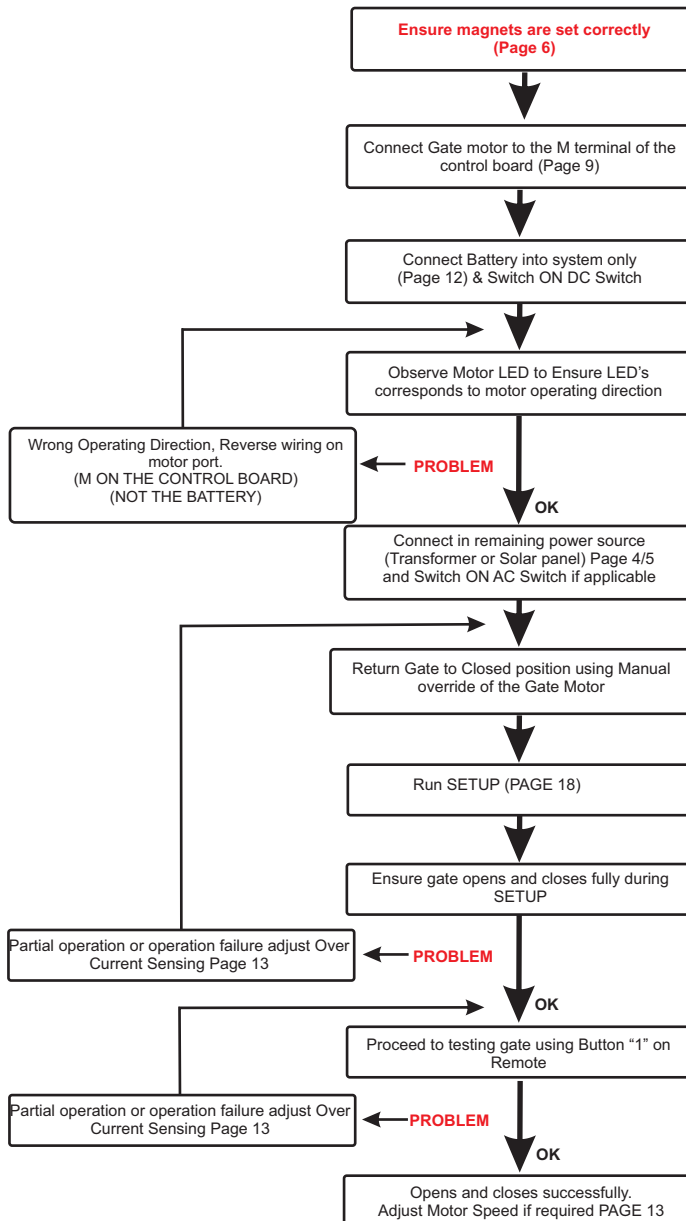

Power Input Connection



DO NOT Connect more than one **PRIMARY** power source at a time.
This Will damage the control board and **VOID** your Warranty.

Please follow the instructions below carefully as this will be the Primary source of power for the Control Board.

1. Ensure that there are no loose strands before inserting the wire into the connector to avoid short circuit.
2. Ensure that the Polarity is correct to avoid short circuit.
3. Ensure all power switches are OFF before connecting.



When running any wiring you MUST always switch off the system power switches AND also unplug the input power source and the batteries.

ON/OFF Switches

Powered Systems:

When the AC Switch is in the ON state it will allow the low voltage AC supply to pass through the system. This switch will NOT charge the batteries until the DC switch is also in the ON state.

Solar Systems:

When the DC Switch is in the ON state it will allow the low voltage DC current to enter the system.

Please note that if the relevant switch is in the off state the system will discharge the batteries.

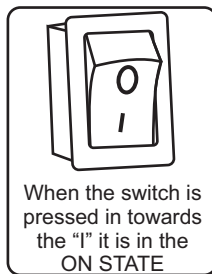
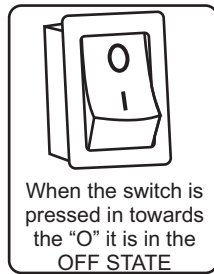

APC External AC Transformer (Low Voltage Systems)

Part No PS-24-10

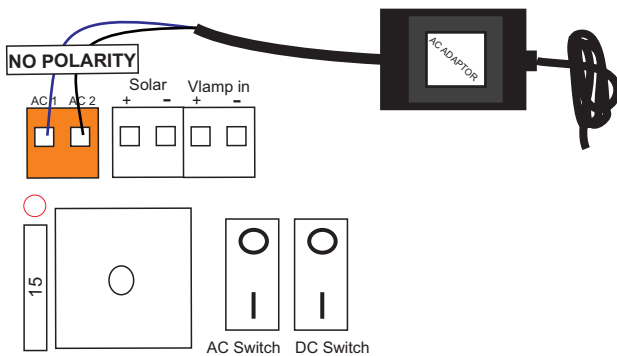

Ensure all power switches are in the OFF position before connecting.

Once the AC Supply is powered and switched ON the RED LED will illuminate indicating the board is powered.

Extending the APC External AC Transformer (low Voltage)

Maximum cable distance: The low voltage transformer can be run upto 80m in cable distance when using a 2mm pair conductor. To run the transformer to maximum capacity the cable must be cut at the LOW VOLTAGE SIDE within 10cm from the output.

Note: Use a weatherproof junction box to terminate the new cable to the transformer.

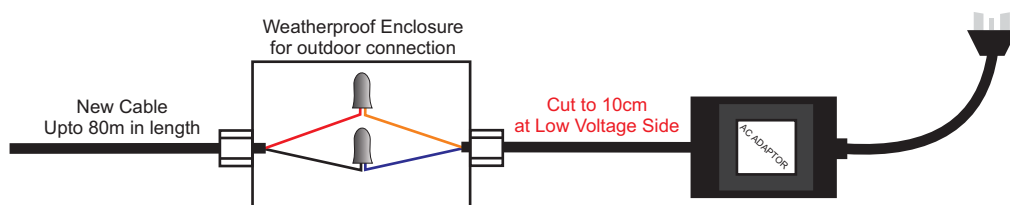



MAXIMUM CABLE DISTANCE BETWEEN MOTOR AND CONTROL PANEL IS 9 METRES

Motors are generally supplied with a 6 metre cable, for distances up to 9 metres the cable should be replaced with a 2.5mm pair.

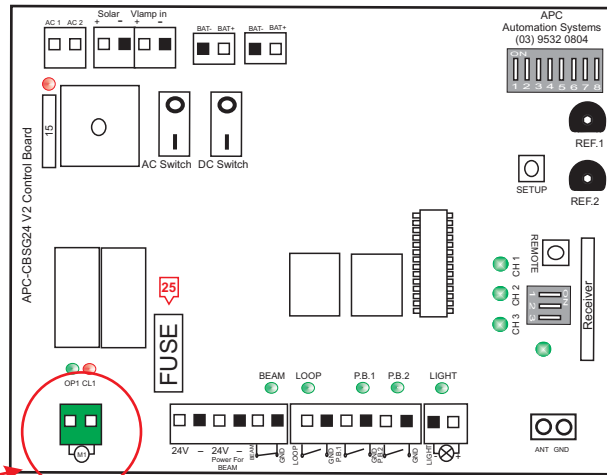

Motor Output Port

Opening to the Left

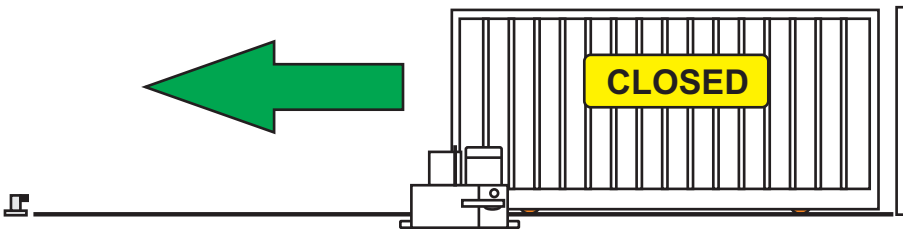

Set the **Motor Output Port** polarity on the main circuit as shown

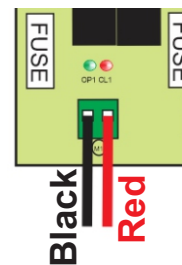

Opening to the Right

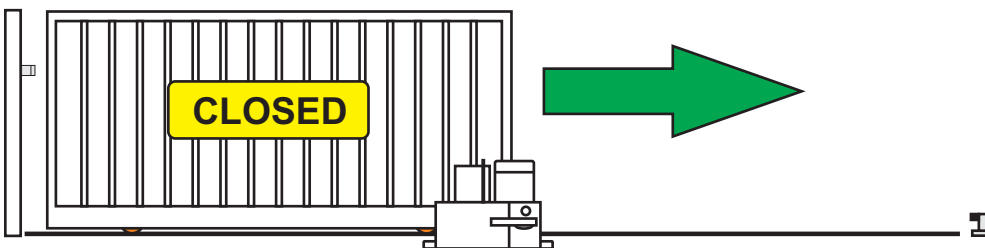

Set the **Motor Output Port** polarity on the main circuit as shown

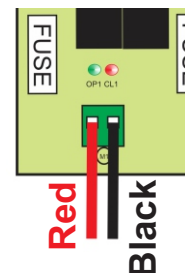

Solar Panel and Bracket Assembly

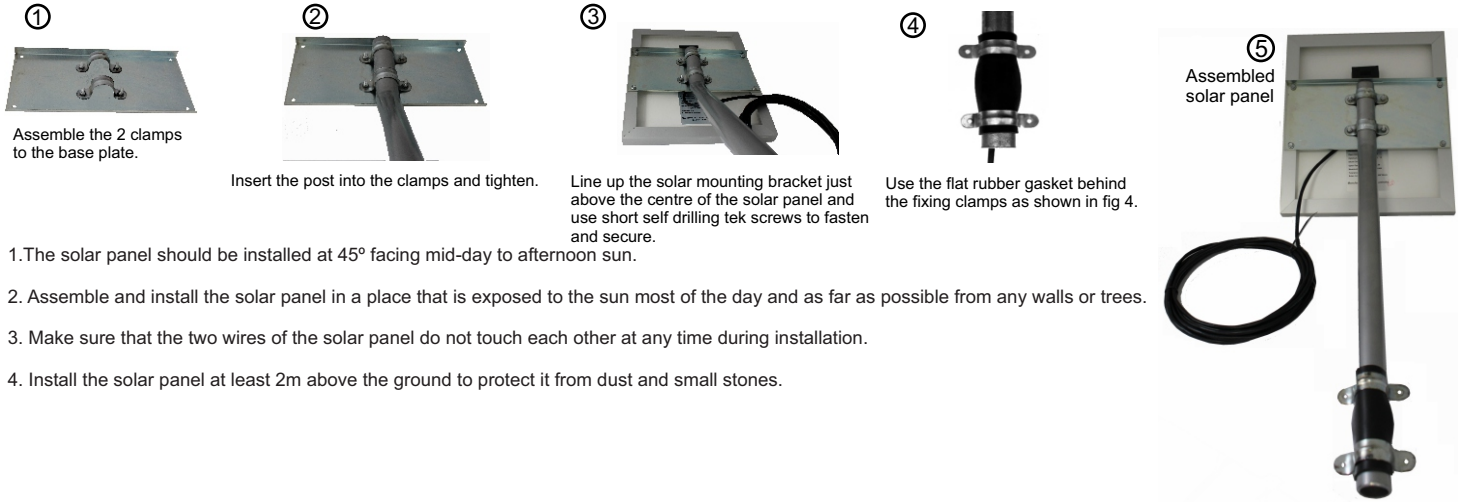

Assemble the 2 clamps to the base plate.

Insert the post into the clamps and tighten.

Line up the solar mounting bracket just above the centre of the solar panel and use short self drilling tek screws to fasten and secure.

Use the flat rubber gasket behind the fixing clamps as shown in fig 4.

1. The solar panel should be installed at 45° facing mid-day to afternoon sun.
2. Assemble and install the solar panel in a place that is exposed to the sun most of the day and as far as possible from any walls or trees.
3. Make sure that the two wires of the solar panel do not touch each other at any time during installation.
4. Install the solar panel at least 2m above the ground to protect it from dust and small stones.

APC Solar Panel Connection (Solar Systems)

Part No APC-SP24

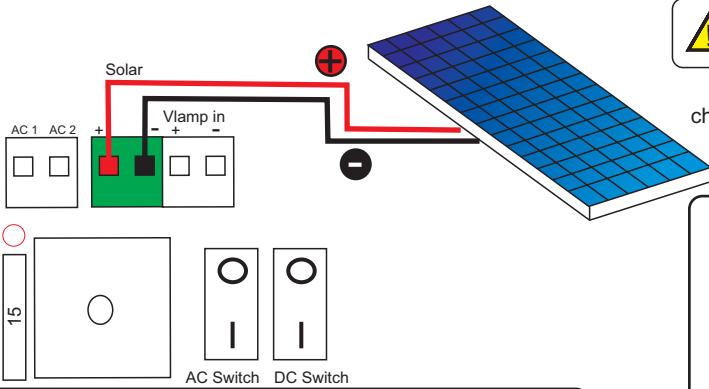

APC 24V Solar Panels ONLY MAXIMUM 60W Total Input

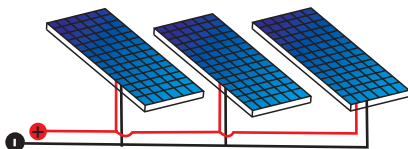

When installing multiple collectors consider installing facing in different directions to gather morning and afternoon sun.

⚠ Ensure all power switches are in the OFF position before connecting.

Multiple APC Solar Panels can be wired in parallel to speed up the charging process (see below). APC Panels are Diode protected to Prevent Short Circuit for multi panel connection.

SUPPORTS APC-SP24-20W, APC-SP24-40W and APC-SP24-60W Panels

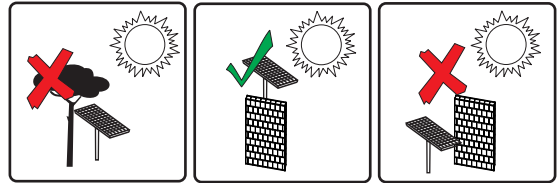

Understanding Solar

1. A solar panel CANNOT be installed under a tree, it requires sun to charge and maintain the batteries.
2. A solar system is often maintenance free BUT the batteries may require an occasional external charge in the winter months due to lack of sun.
3. Constantly powered accessories such as wired keypads will increase the standby current draw, solar panel or battery upgrades may be required if insufficient sun collection is not achieved.

Battery Connection



Incorrect connection of the battery will cause damage and will immediately VOID warranty

Before Connecting your batteries ensure that the “DC Switch” is in the OFF Position.

1. Unplug battery connector from control panel.
2. Connect the Red battery lead to the Red (Positive) terminal on the battery 1.
3. Connect the Black battery lead to the Black (Negative) terminal on the battery 2.
4. Connect Negative of battery 1 to positive of battery 2.
5. Plug connector into battery input port on the control board.

Repeat the above if dual batteries are to be connected (Solar systems).

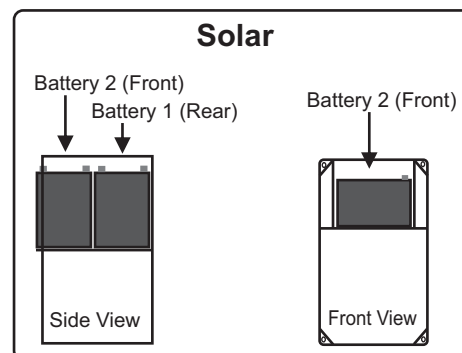
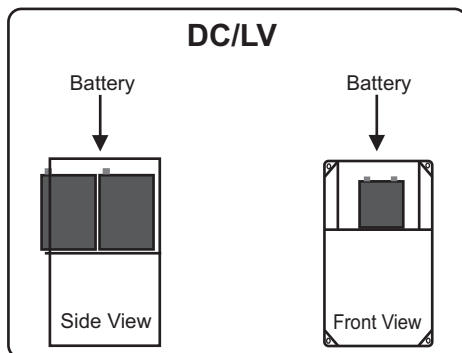
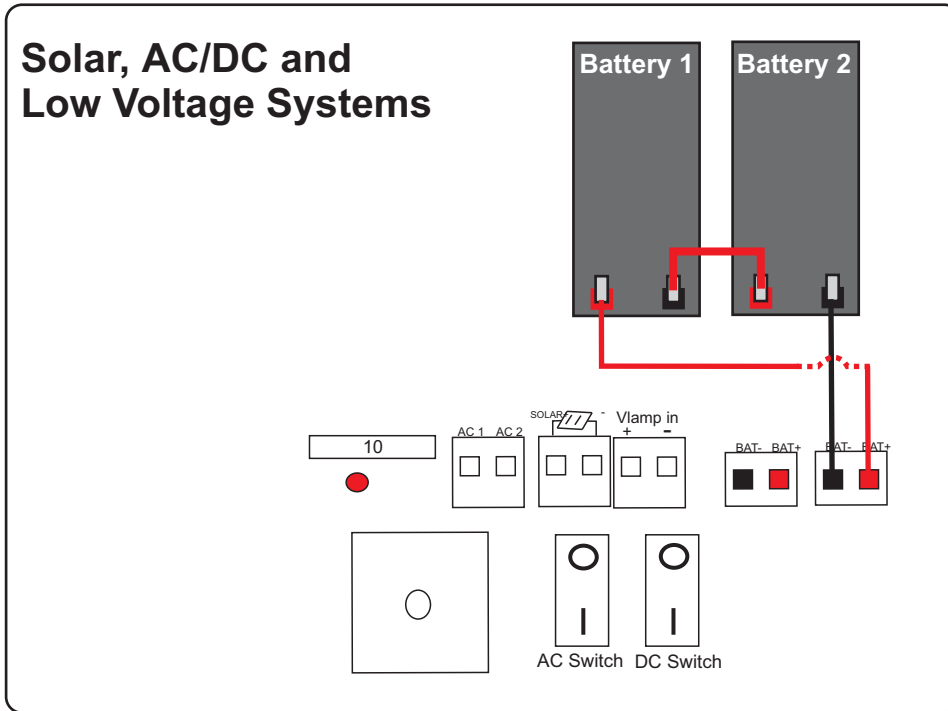

APC Smart Receiver Configuration

Remote's are Factory Paired when purchased in a kit



The APC Smart remote system is designed for user friendly operation. Once a controller is paired into the system it will automatically function based on your system configuration.

To adjust your Control panels functions adjust the DIP switches based on your configuration requirements.

Full Opening CH1 ON CH1 OFF	Set DIP 1 to the ON Position to Activate the Full gate opening Function.	Pedestrian Opening CH2 ON CH2 OFF	Set DIP 2 to the ON Position to Activate the Pedestrian Opening Function. This is 5 seconds of the opening only.
Party Mode CH3 ON CH3 OFF	Set DIP 3 to the ON Position to Activate the Party Mode Function on your remote. Only Required if you are using auto close and wish to cancel from your remote for ONE cycle.		

APC Remotes and Wireless Equipment

Pairing

The original remote's supplied with the sliding gate opener system are already paired.

- Press the small REMOTE button once on the circuit board and the LED Indicator will start to flash.
- Press the Number 1 button on the remote for 1 second.
- Press the Number 1 remote button to test operation.

Pairing APC Wireless Push Buttons

Ensure the switch is in the ON state using the supplied key

- Press the small REMOTE button once on the circuit board and the LED Indicator will start to flash
- Press the wireless push button for 1 second.
- Press the button to test operation.

Pairing APC Wireless Keypads

Use the default pin codes, after successful pairing then you can change the pin numbers

- Press the small REMOTE button once on the circuit board and the LED Indicator will start to flash
- Type 1 1 1 1 #
- Type 1 1 1 1 # again to test operation.

1
Press this REMOTE button once and the LED indicator will start to flash.

2
Press the button on the remote button you wish to use for 1 second.
OR
Press the Wireless Push button.
OR
Type in the pin code on the Wireless Keypad.

Deleting

- Press and hold the REMOTE button until the LED indicator is on solid then release the REMOTE button.

WARNING: This will delete all wireless equipment from the system.

Setting the Motor Speed

A **SETUP** cycle is always required to learn the travel time for the gate, the speed adjustment is set before performing the **SETUP** cycle.



Four choices are available for each speed adjustment, two will adjust the fast speed and two will adjust the slow speed. For solar applications generally the fastest speed combinations are used. For powered applications the speed options will vary depending on gate size/weight. For gates on a slope the speeds may need fine tuning.

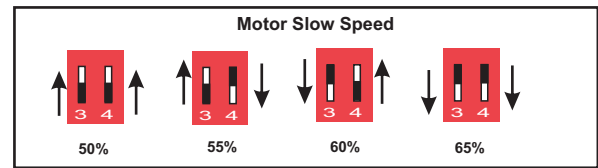
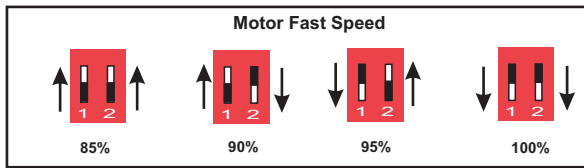

Enable/Disable Slowdown

For powered systems the slowdown is necessary and should be ON.



The slowdown cycle is not 100% necessary in a solar application, it can be turned On/Off if deemed necessary. If the operator struggles in operation turn OFF the slowdown. If the operator crashes turn ON the slowdown.

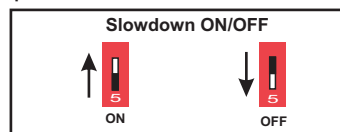

Setting the Auto Close Duration

The simple to set Auto Close has 4 easy to adjust settings; 5,30,90 and 180 Seconds.



To turn on Auto Close Set DIP Switch 6 in the ON position followed by DIP 7 and 8 based on your desired Auto Close duration.

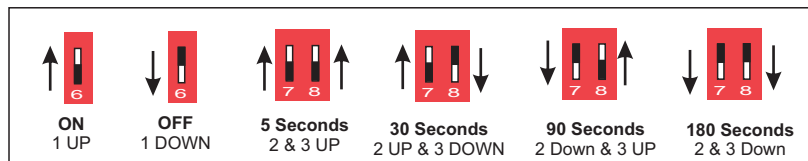

A PE Sensor or Reflective sensor MUST be connected when using the Auto Close Feature

Over Current Sensing



Ref 1 and Ref 2 Trim Pot

More Sensitive



Less Sensitive

What are the Ref 1 and Ref 2 Trim Pots

These pots directly adjust the over current sensitivity of the control board, they are adjusted **ONLY** when the gate fail to fully open/close **UNDER NORMAL OPERATING CONDITIONS**. Adjusting these dials should only be considered after ALL aspects of the installation are confirmed.

REF 1 Directly controls the over current sensitivity for the **FULL SPEED** portion of the normal operating cycle.

Furthermore because the **SETUP** cycle is only run in the fast speed the REF 1 is the only trim pot that should be adjusted if the problem is occurring in **SETUP**.

REF 2 Directly controls the over current sensitivity for the **SLOW SPEED** portion of the operating cycle and also the **TRANSITION** speed between full speed and slow speed. It is not used in the **SETUP** cycle.

IMPORTANT: This step must be adjusted correctly to ensure that the gate is not inconsistent in its operation **BUT** will continue to sense obstructions and wind loading. The adjustment needs to be set taking into consideration that a different temperature after installation will cause a greater resistance.

How to adjust

Adjusting the pot **CLOCKWISE** will **DECREASE** the sensitivity thus making the system **LESS sensitive** to weight and resistance.

Adjusting the pot **ANTI-CLOCKWISE** will **INCREASE** the sensitivity thus making the system **MORE sensitive** to weight and resistance.

The pots should be adjusted only in 1mm increment turns til the gate does not over current sense during its travel.

Using your Wireless Equipment

APC-RC4S
15 Metre Operational Range*

- * All guideline distances will vary from site to site
- * All operating ranges are based on a clear environment (interference free)
- * Metal fences will drastically decrease operating ranges
- * All operating ranges can be boosted with the ANT-1 Antenna (page 14)

Type in the 4 digit pin code then press #

Default:
1111# For Full Gate Opening
2222# For Pedestrian Opening

APC-KP2W
20 Metre Operational Range*

Activate the Push Button by turning the key switch to the ON position.

Press the button to operate.

PBS-KW **PBD-KW**

5 Metre Operational Range*

APC-RC450S
400+ Metres Operational Range*

Party Mode (Cancel Auto Close)

To Cancel the Auto Close feature for ONE cycle

RC450S Remote: Simply press and HOLD the "C" button on your remote RC450S Remote for 5 SECONDS whilst the gate is in the OPEN position.

RC4S Remote: Simply press and HOLD the CH3 button on your remote RC4S Remote for 5 SECONDS whilst the gate is in the OPEN position.

APC Smart Wireless Button Configuration

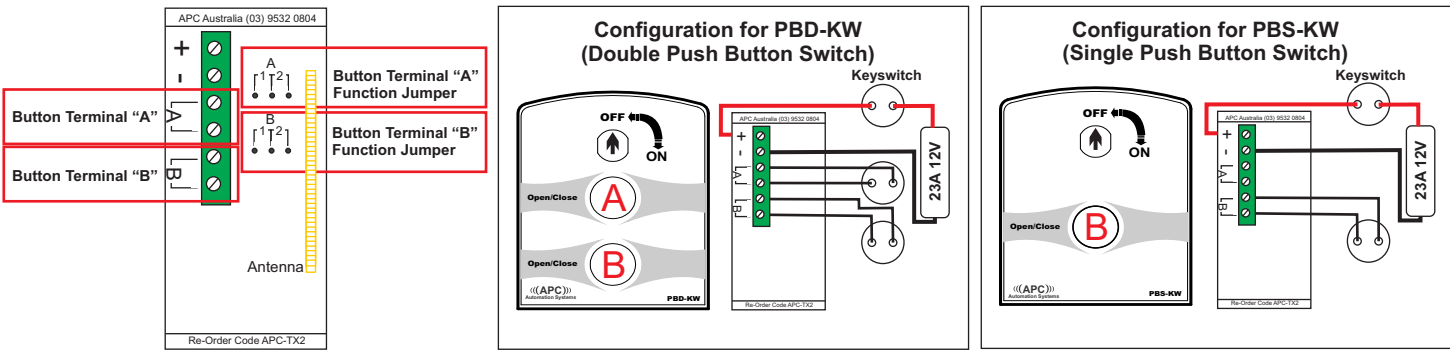

When the jumper is set to "1" and center pin the designated output will operate double gates. FULL Gate Setting PEDESTRIAN Gate Setting

When the jumper is set to "2" and center pin the designated output will operate a single gate.

APC-KP2W Pin number programming (4 Digit)

The APC-KP2W has TWO channels, each channel can control a different function on an APC Smart control board. To continue adding pin numbers after adding the first repeat the steps below.

Note: When you add your first pin number to each channel the default pin code will automatically be erased.

-Channel 1 Full Gate Operation (Supports 8 Pin Codes)

Master Code

 Pin Code

-Channel 2 Pedestrian Gate Operation (Supports 3 Pin Codes)

Master Code

 Pin Code

APC Wired Push Button Connection

Push buttons are used for opening and closing the gates without using a remote.

Push buttons can be used for a vast amount of purposes ranging from basic access control for visitors, workers or taking out the bins.

 For **Pedestrian Gate** operation connect the Button component to **PB1 and GND**
 For **Full Gate** operation connect the Button component to **PB2 and GND**

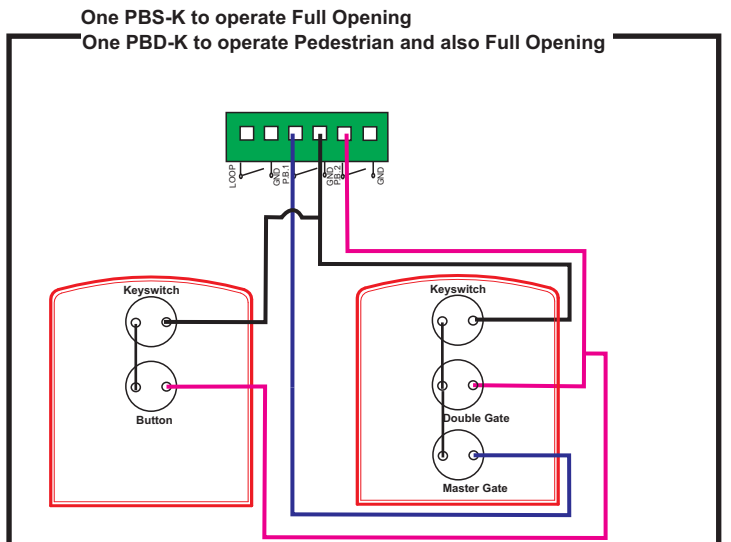
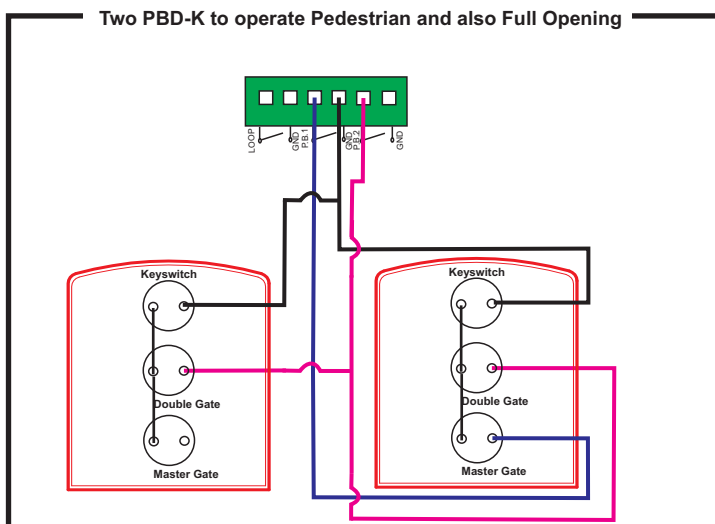
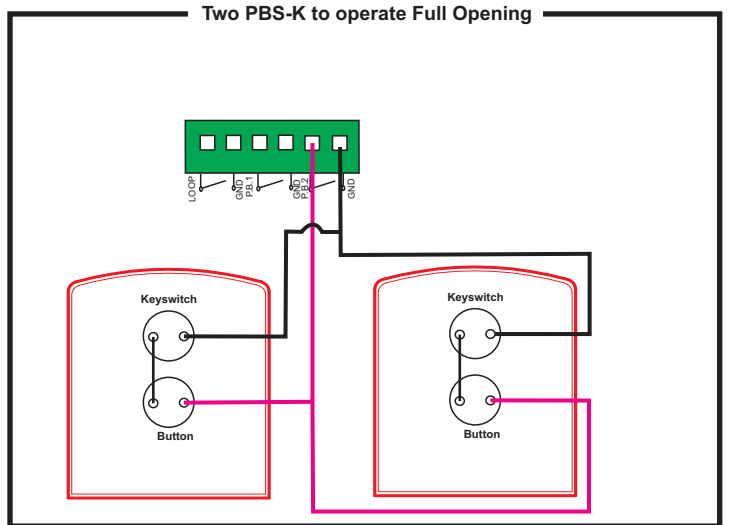
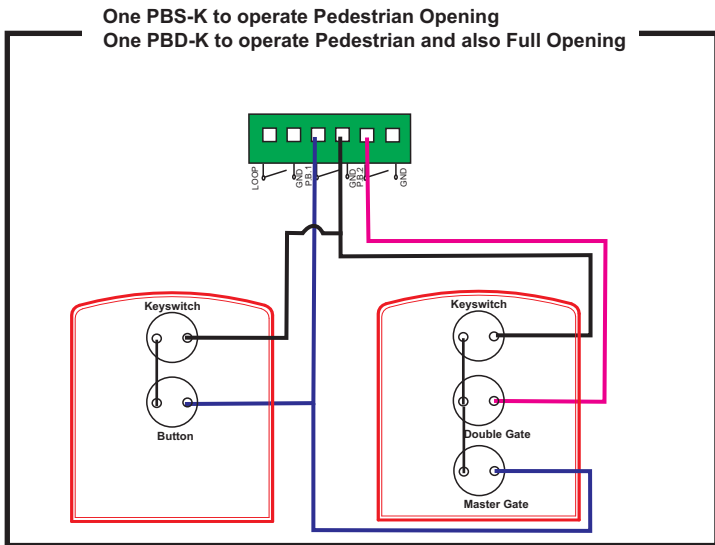
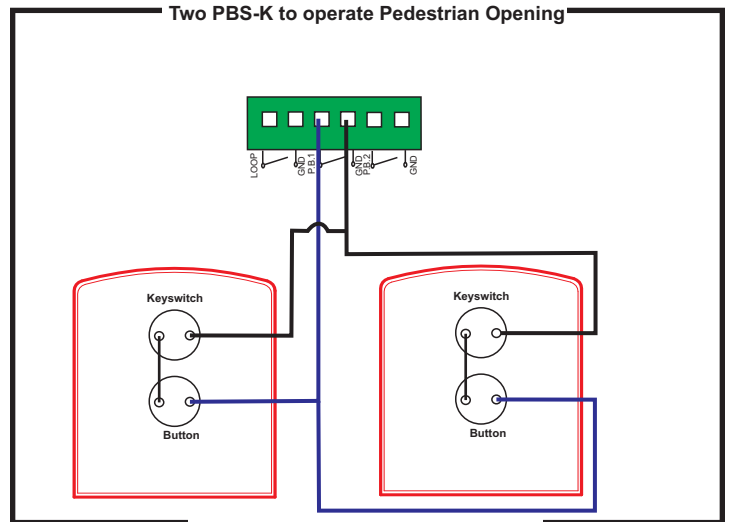
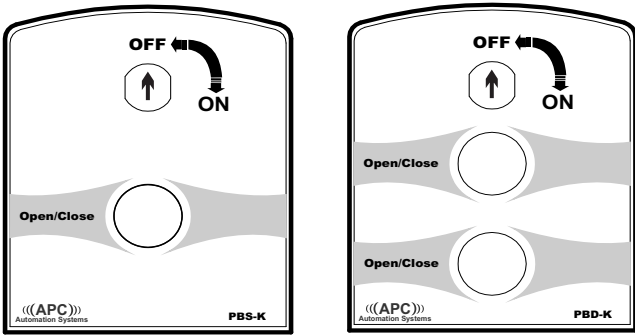

APC Connect4 GSM Receiver

A GSM Receiver is the absolute most flexible form of access control. Providing there is good mobile reception at the gate the GSM switch can operate the gate from anywhere in the world. When receiving a call it will automatically reject the call and open or close the gate. SIM CARD IS NOT SUPPLIED.

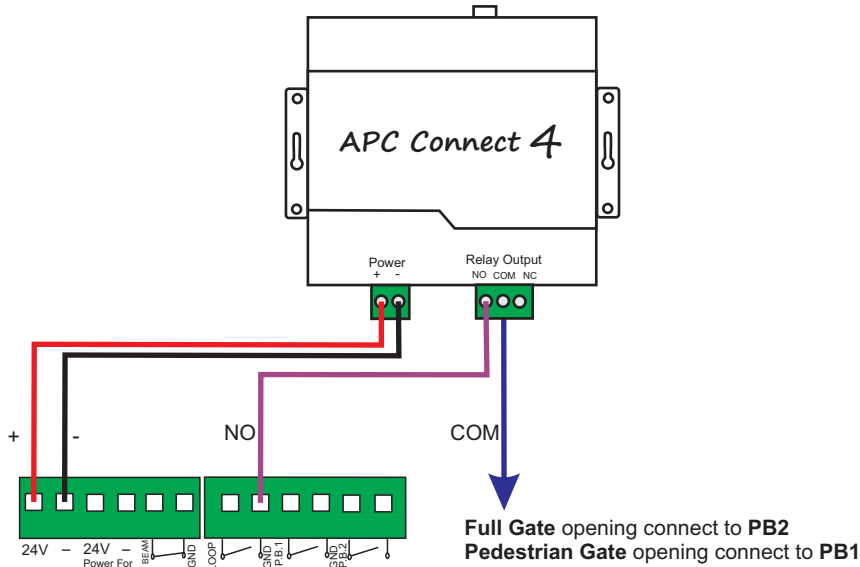

Connecting an APC Keypad (APC-KP1-C)

Unlike a push button entry switch using a keypad can provide a much higher security for access control for guests, workers, tenants etc.

Using a keypad will allow you to manage the users by adding and deleting as required. Its backlit illumination also allows for ease of use at night.

i When the Input is Triggered the PB1/PB2 LED will momentarily illuminate

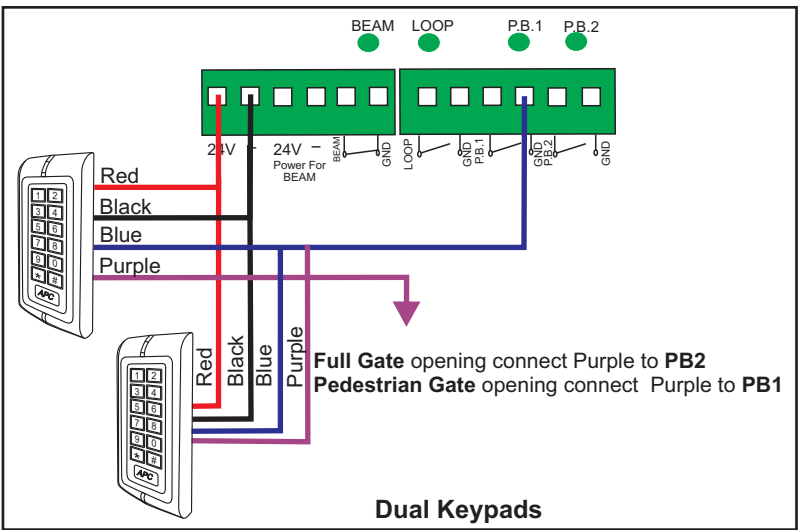
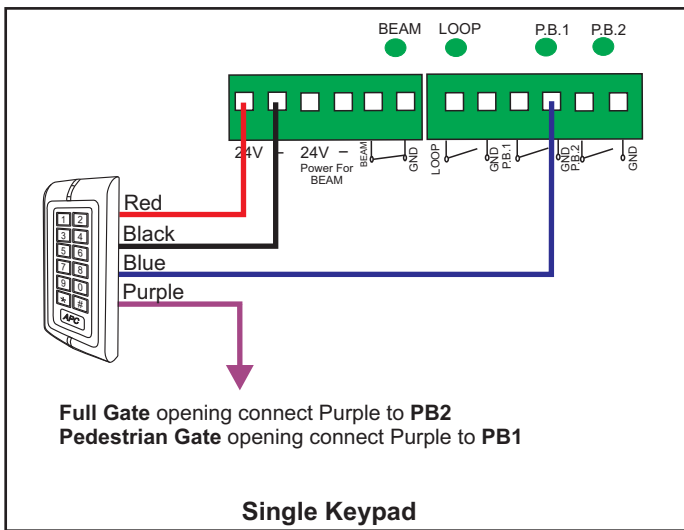

Quick Programming Pin Code

- *8888888# Master Code used to enter programming only
- 1 To enter Pin code programming
- User ID # Any number between 1-999, this number is unique to each pin code/swipe tag and cannot be used twice
- Pin Code # The Pin code you would like to use to open the gate (4-6 Digits)
- * To Exit programming and return to standby state
- *

Quick Programming Swipe Tag

- *8888888# Master Code used to enter programming only
- 1 To enter Pin code programming
- User ID # Any number between 1-999, this number is unique to each pin code/swipe tag and cannot be used twice
- SWIPE # Swipe the tag past the black APC window
- * To Exit programming and return to standby state
- *

Gate System SETUP Cycle

Before beginning this step you must first ensure that all your motor wiring connections are connected correctly, there are no loose wire strands and all connection points are joined and insulated correctly

The purpose of the SETUP cycle is so that the gate control panel can learn its opening and closing limits and learn its slowdown. If the control panel is not setup it may run inconsistently and/or may not reach its stopping points and/or slow down incorrectly..

Check your Magnet positions!

Preliminary checks prior to SETUP cycle

- Ensure gear rack is not binding with **ZERO** resistance
- Ensure gate is free of **ALL** bowing
- Ensure that the motor is firmly fixed
- Ensure that the connections are all correct with no loose wire strands
- Ensure that magnets are set correctly
- Ensure that the motor polarity is set correctly

GATE MUST BE CLOSED BEFORE BEGINNING THE STEPS BELOW

1
Press and **HOLD** the "Setup" Button.

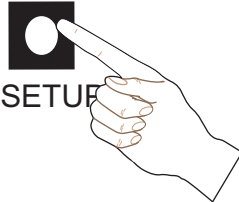

2
Release the setup button **IMMEDIATELY** after the buzzer sounds.



3
Press and **HOLD** "1" on the remote control for one second then release.



The SETUP cycle will now open and close the gate at full speed so that it can learn the time travel distance. It will follow the sequence illustrated below. Once the cycle below is completed the buzzer will sound indicating completion.

4 **Opening**

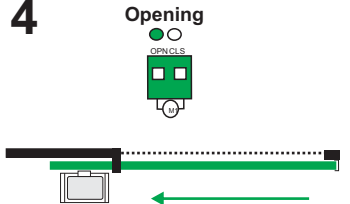

Gate will open to the full open position at full speed. Once at the open position the motor and the **GREEN OPN** indicator LED will switch off.

5 **Closing**

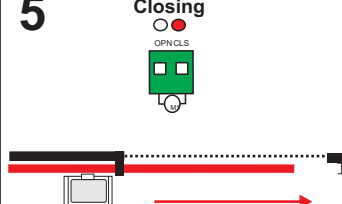

Gate will close to the full close position at full speed. Once at the closed position the motor and the **RED CLS** indicator LED will switch off.



Important !

Observe the LED indicators as illustrated and detailed above, if the gate reaches the open or close position and the motor LED does not switch off immediately switch off all power sources and see the troubleshooting section.

6  The Buzzer will now sound indicating completion of the setup cycle.
If the gate did not reach any of the full open or close cycles or has missed part of the cycle see the troubleshooting section.

APC Loop Detector For Auto Gate Opening

The APC Loop Detector will detect vehicles over the induction loop and automatically operate the gates to open.

-  When the Loop is Triggered the LOOP LED will momentarily illuminate.
-  A PE sensor setup set MUST be used in this application.

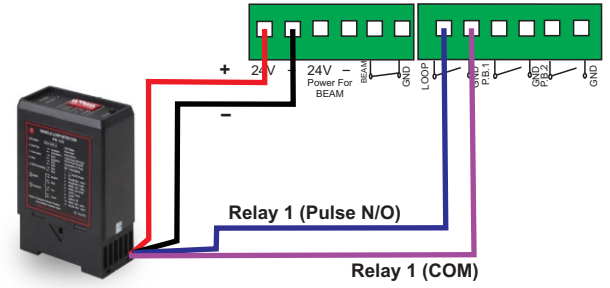

Please refer to the loop detector installation manual for the specific instructions for installation.

Eyevision® 2 Wire Intercom System Connection

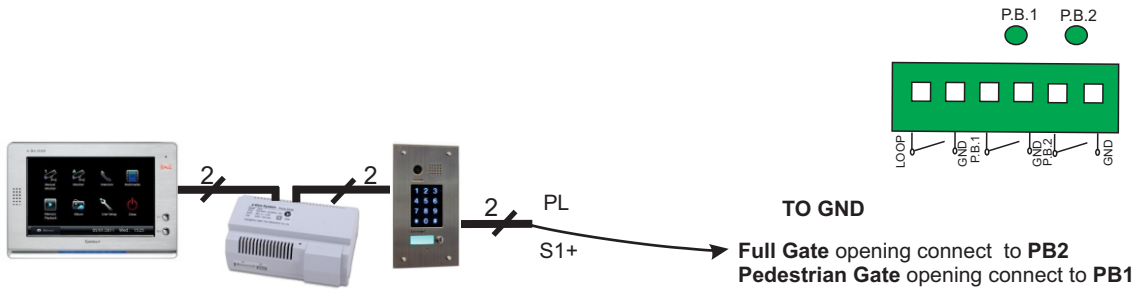

Eyevision® 4 Wire HYBRID Intercom and WIFI intercom System Connection

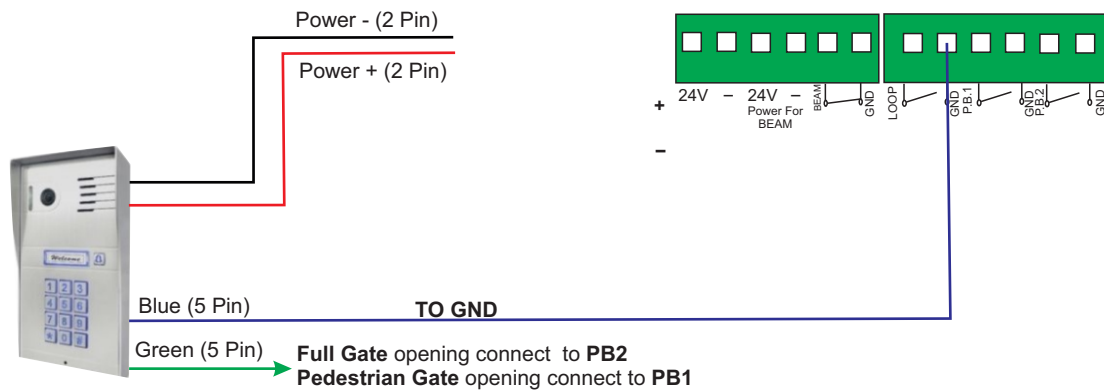

Connecting a Single PE Sensor (APC-PE-2000)

APC-PE-2000 PE sensor (Transmitter & Receiver) **must be connected back to the control panel.**

Install the PE-2000 Photoelectric sensor on the first entry point of the driveway from post to post at approx. 500mm above ground level.

The Transmitter and the Receiver must be inline with each other
(The inline LED will be off when aligned with the transmitter).

i The PE Sensor output will only output voltage to the PE sensor connection terminal only during the closing cycle

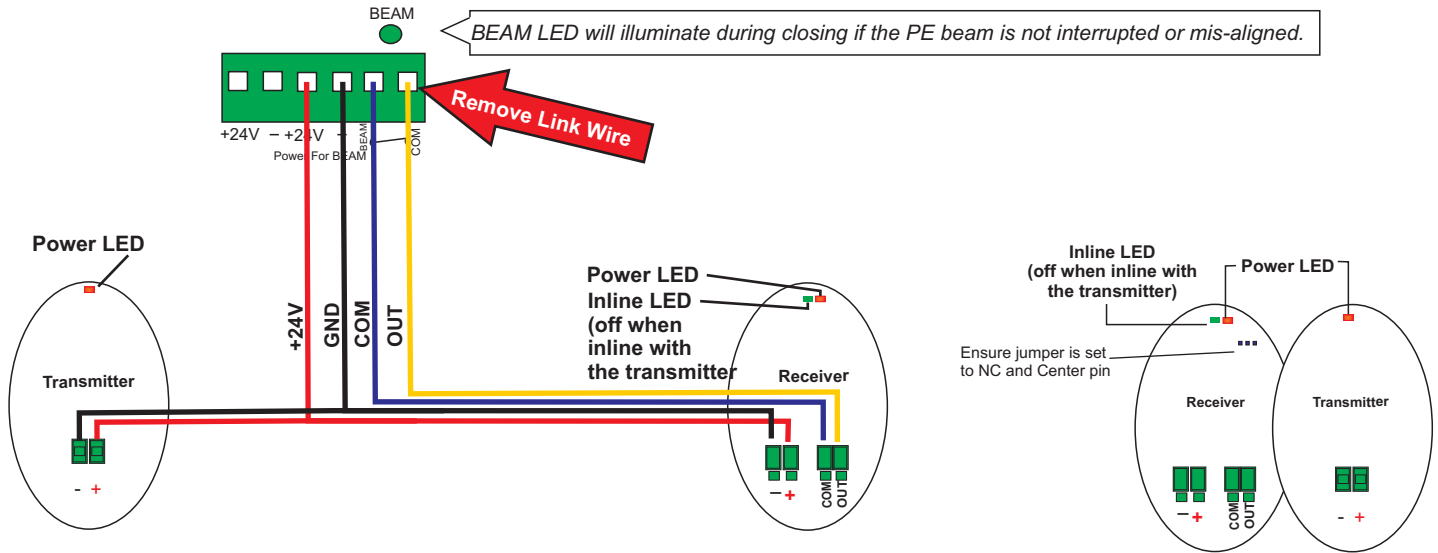

Connecting a Single Retro Reflective Sensor (APC-RR-11)

APC-RR-11 Reflective sensor (Transmitter only) **must be connected back to the control panel** (see wiring diagram).

Install the RR-11 Reflective sensor on the first entry point of the driveway from post to post at approx. 500mm above ground level.

The Transmitter and the Reflector must be inline with each other
(The yellow inline LED will be ON when Aligned with the transmitter).

i The PE Sensor output will only output voltage to the PE sensor connection terminal only during the closing cycle

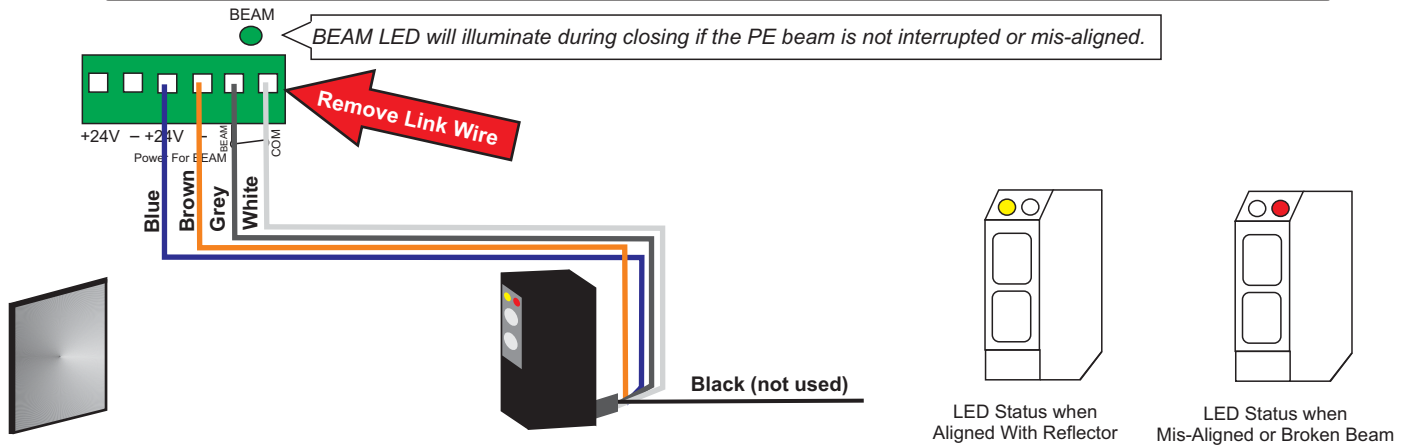

Connecting a Courtesy Light

Courtesy Lights are used to alert pedestrians to be cautious as there may be vehicles entering and exiting. A Strobe light is generally used due to their low drawing consumption to operate.

This internal relay will support an output of 24V 10W Maximum, The 24V source power used must be external to the system. Failing to follow the above will cause damage to the system.

! THIS OUTPUT IS NOT USED TO CONNECT DRIVEWAY LIGHTS

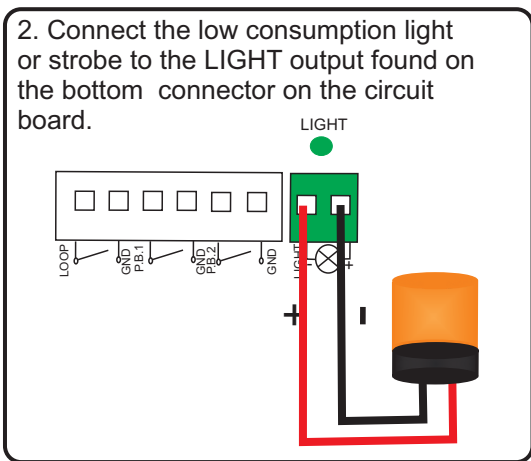
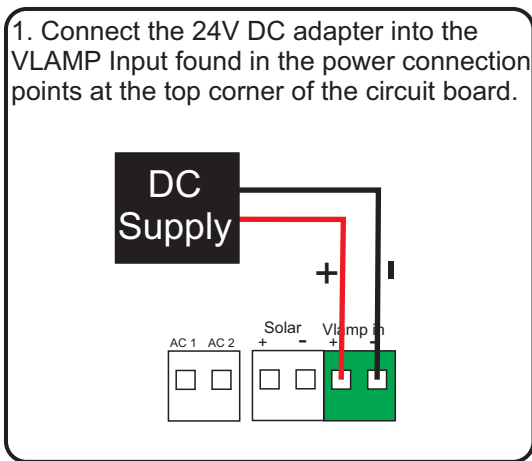

i This output is active when the gate is Opening, Idle in the open position and closing.
The output will turn off when the gate is Closed or Party Mode has been activated.

Connecting an APC-ANT1 External Antenna

The ANT-1 external antenna can boost the remote range drastically in most installations.

Suitable for Residential, commercial and rural installations this antenna used in conjunction with the **APC-RC450S** remote can boost functionality **UPTO 800m** distance. When used in conjunction with **APC-RC4S** it can boost functionality **UPTO 80m** distance.

W Inner core of the antenna cable to **ANT** on the control board.
Outer core/shield of the antenna to **GND** on the control board.

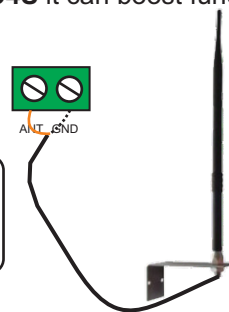

Compatible Equipment

The equipment listed below does not affect the warranty of the control panel and have been tested and approved for use. Limited warranty is applied to the control panel when used with third party equipment.

Solar Panels

- APC-SP24-20W
- APC-SP24-40W
- APC-SP24-60W

Sensors

- APC-PE2000
- APC-RR-11
- APC-LD2-12-24VACDC

Keypads

- APC-KP1-C
- APC-KP1-D
- APC-KP2W

Push Buttons

- APC-PBS (K/W/K/KW)
- APC-PBD (K/W/K/KW)
- APC-PBD211
- APC-PBD164

Remotes

- APC-RC4S
- APC-RC450S
- APC-RC4-SV

Receivers

- APC-Connect4

Internal Transformer

- PS-24INT

External Transformers

- PS-24-10

Courtesy Light

- APC-LAMP24

Troubleshooting

Scenario 1

Problem:
Gate will not OPEN/CLOSE Fully.

Possible Cause:
Step 1: Review the preliminary steps found in the setup section of the manual, check your gate motor installation and magnet positions.
Step 2: ONLY after completing step 1: Adjustment of System Sensitivity (REF) Further instructions found on Page 6 .

Solution:
Run the SETUP cycle from the CLOSED position, The must open once and close once.
if the gates do not run the full cycle an adjustment of REF may be required.

Further Information:
Contact technical support prior to adjusting REF.

Scenario 2

Problem:
System will not power ON (NO LED'S).
System is powered but will not function

Possible Cause:
Power supply not switched on (AC/DC).
Low battery voltage (SOLAR).

Solution:
Ensure that your power Source is ON/Allow ample time for batteries to charge.

Scenario 3

Problem:
Gate will not slow down before reaching the open and close positions.

Possible Cause:
Setup Cycle not completed correctly.
Motor Speed/Slowdown is set to high.

Solution:
Run the SETUP cycle from the CLOSED position the gate must open once and close once.
If the gates do not run the full cycle refer back to scenario 1.
Ensure that the motors switch off at the end of each cycle (using the motor status indicators).
Adjust the motor speed lesser than current value.

Further Information:
If the gate does NOT switch off at the end of there OPEN/CLOSE power off IMMEDIATELY and adjust your magnet position.

Scenario 5:

Problem:
Gate opens but does not close.

Possible Cause:
Broken Beam Circuit.

Solution:
Reconnect the original loop wire between Beam and GND and check if it is now functional.

Further Information:
If the unit becomes functional first check the accessories fuse then check the wiring and alignment of your safety sensor and power.

Scenario 6:

Problem:
Solar system will not operate but lights are ON.
Control panel beeps 3 times.

Possible Cause:
Low battery voltage.

Solution:
Test your battery voltage. If voltage is low allow the system time to charge through the system.

Further Information:
Alternately the batteries can be charged using a trickle charger whilst DISCONNECTED from the system.



APC WARRANTY

APC Automation Systems warrants the original purchasers or the APC gate(s) opening system for a period of twelve months from the date of purchase (not installation), the product shall be free of defects in materials and workmanship under normal use.

During the warranty period, APC shall, as its option, repair or replace any defective product upon return of the product to its factory, at no charge for labour and materials.

Any replacement and/or repaired parts are warranted for the remainder of the original warranty,

The original owner must promptly notify APC in writing that there is defect in material or workmanship, such written notice must be received in all events prior to expiration of the warranty.

International Warranty

APC shall not be responsible for any freight fees, taxes or customs fees.

Warranty Procedure

To obtain service under this warranty, AND AFTER CONTACTING APC, please return the item(s) in question to the point of purchase.

All authorized distributors and dealers have a warranty program, anyone returning goods to APC must first obtain an authorization number. APC will not accept any shipment for which prior authorization has not been used.

Conditions to Void Warranty

This warranty applies only to defects in parts and workmanship relating to normal use. It does not cover:

- Damage incurred in shipping or handling
- Damage caused by disaster such as fire, flood, wind, earthquake or lightning
- Damage due to causes beyond the control of APC such as excessive voltage, mechanical shock or water damage
- Damage caused by unauthorized attachment, alterations, modifications, or foreign objects.
- Damage caused by peripherals (unless such peripherals were supplied by APC)
- Defects caused by failure to provide a suitable installation environment for the products
- Damage caused by usage of the products for purpose other than those for which it was designed.
- Damage from improper maintenance
- Damage arising out of any other abuse, mishandling, and improper application of the products.

Under no circumstances shall APC be liable for any special, incidental, or consequential damages based upon breach of warranty, breach of contract, negligence, strict liability, or any other legal theory. Such damages include, loss of profits, loss of the product or any associated equipment, cost of capital, cost of substitute or replacement equipment, facilities or services, down time, purchaser's time, the claims of third parties, including customers, and injury to property.

Disclaimer of Warranties

This warranty contains the entire warranty and shall be in lieu of any and all other warranties, whether expressed or implied (including all implied warranties of merchantability or fitness for a particular purpose). And of all other obligations or purporting to act on its behalf to modify or to change this warranty, nor to assume for it any other warranty or liability concerning this product.

Out of Warranty Repairs

APC will at its option repair or replace out-of-warranty products which are returned to its factory according to the following conditions. Anyone returning goods to APC must first obtain an authorization number.

APC will not accept any shipment whatsoever for which prior authorization has not been obtained. Products which APC determines to be repairable will be repaired and returned. A set fee which APC has been predetermined and which may be revised from time to time will be charged for each unit repaired. Products which APC determines not repairable will be replaced by the nearest equivalent product available at that time. The current market price for the replacement product will be charged for each replacement unit.