



# The Next Generation in Locking



## 4321 C4 GARAGE DOOR LOCK INSTALLATION INSTRUCTIONS

### FRELATCH AND DEADLOCK MODES

This lock can be used in two different modes. Freelatch and Deadlock mode. This is an explanation on how to set it up in the chosen mode before fitting to the door.

#### 1. ORIENTATING THE BARREL

There is an 'F' for Freelatch and a 'D' for Deadlock mode on the inside of the mechanism body. The pin chamber must be positioned in the same side as the mode that is chosen. Push the barrel assembly into the desired side until the stop.

Pin chamber must be here for Deadlock.

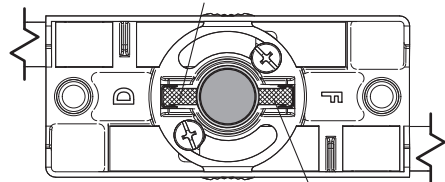

Pin chamber must be here for Freelatch.

#### 1a. FRELATCH MODE ONLY.

If freelatch mode has been selected, then the key

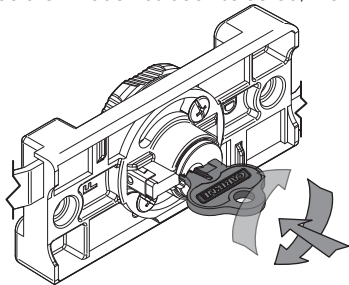

must be inserted and rotated 180°. This enables the correct orientation of the drive cam. **IMPORTANT:** Be careful not to pull the key out of the barrel whilst in this position.

#### 2. ATTACHING THE DRIVE CAM

This is applicable for both modes. Turn the lock so you have the turn knob facing you. Push the drive cam into the hole and screw into position.

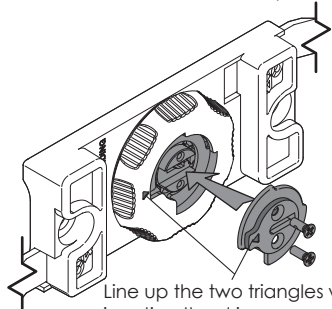

Line up the two triangles when inserting the drive cam.

#### 3a. FRELATCH MODE DRIVE CAM POSITION

Now the drive cam is fixed in position, rotate the key back 180° and remove it. This will put the drive cam in the position shown below.

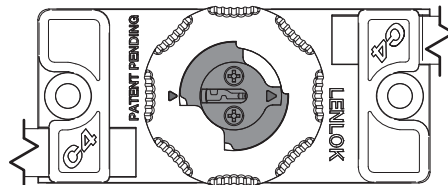

### ATTACHING LOCK TO THE DOOR

#### 1. USING THE TEMPLATE

If necessary, use the template to cut an aperture for the fascia to slide into.

#### 2. ATTACHING FASCIA TO GARAGE DOOR

Use masking tape provided to hold fascia in place against the door.

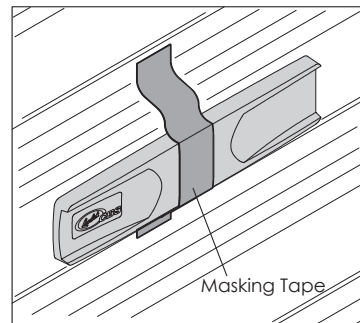

Masking Tape

#### 3. FIXING LOCK MECHANISM TO FASCIA

Use the Phillips head M5 screws for Freelatch mode and the Tamperproof screws for Deadlock mode. Use a Phillips or Flat head screwdriver to secure mechanism to fascia.

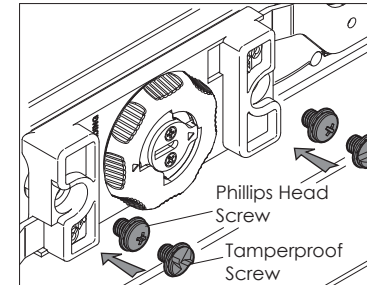

#### 4. ATTACHING THE LOCKING ARMS

Slide the garage locking arms onto the lock arms of the mechanism. Fix in place

with the M4 Phillips head or Tamperproof (for deadlock) screw depending on the mode selected for the lock.

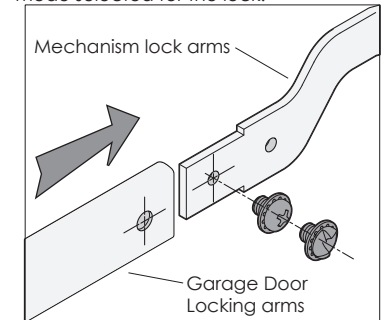

#### 5. TEST THE LOCK

Carefully remove the masking tape and test the lock. Turn the knob, ensure the arms move freely and key operates correctly.

#### 3b. DEADLOCK MODE DRIVE CAM POSITION

The drive cam is now in the position shown below. Test the lock by inserting the key and rotating it 360° and removing it.

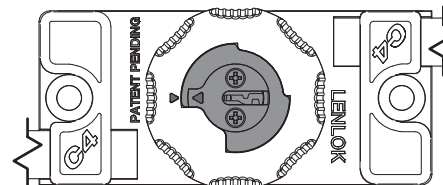

### USING THE REVERSE KEY FUNCTION IN DEADLOCK MODE (C4R KEY)

#### A. C4 BARREL

Push Reverse C4 Key into the slot and turn to retract or extend locking arms. Due to the patented cam design, in the locked position the drive cam cannot be removed even if the cam screws are removed.

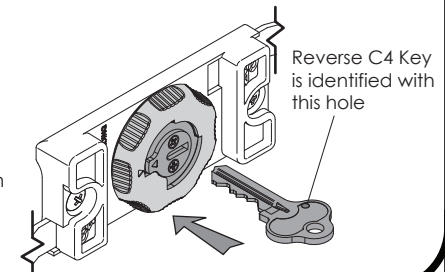

Reverse C4 Key is identified with this hole

**WARNING** IN DEADLOCK MODE, THE REVERSE KEY MUST BE USED TO UNLOCK THE DOOR FROM THE INSIDE. LOCK AND KEY, HOWARD F HUDSON AND THE DAVCOR GROUP DO NOT RECOMMEND THE USE OF THE DEADLOCKING FUNCTION ON DOMESTIC OR COMMERCIAL APPLICATIONS WHERE EGRESS IS REQUIRED, AND WILL THEREFORE ACCEPT NO RESPONSIBILITY FOR ANY CLAIMS FOR LOSS OR INJURY AT SITE WHERE DEADLOCKING FUNCTION HAS BEEN INSTALLED.

**NOTE** DUE TO VARIATIONS BETWEEN DIFFERENT DOOR MANUFACTURERS, MODIFICATION OF EXISTING LOCK CUTOUTS MAY BE REQUIRED FOR A GOOD FIT.

### GARAGE DOOR TEMPLATE

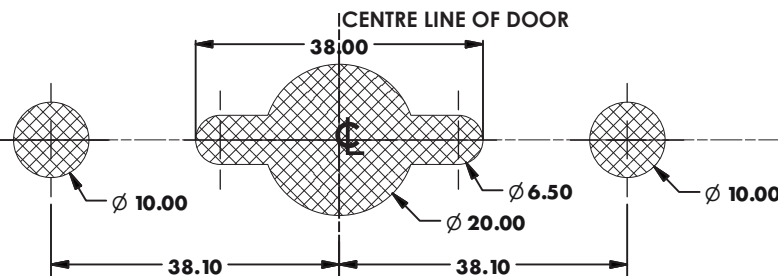

CUT ALONG LINE AS REQUIRED

**WARNING**  
Please keep contents away from small children, may lead to suffocation.

**NOTE**  
Please dispose of plastic bags & other packaging in a thoughtful manner.



ALL DIM'S IN MM