

# Dynamos

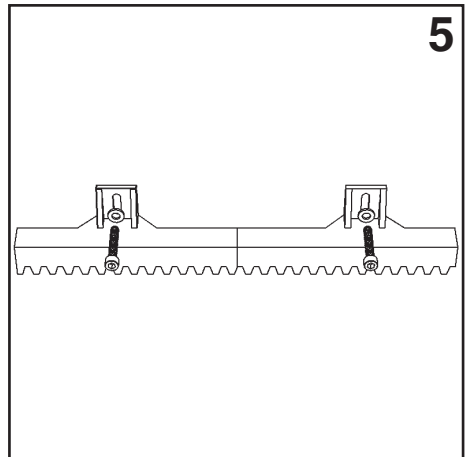

**INSTRUCTION MANUAL**

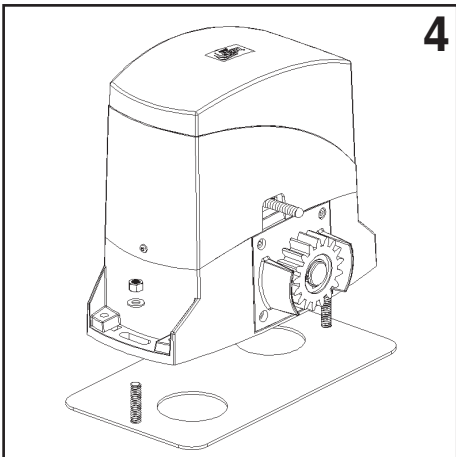
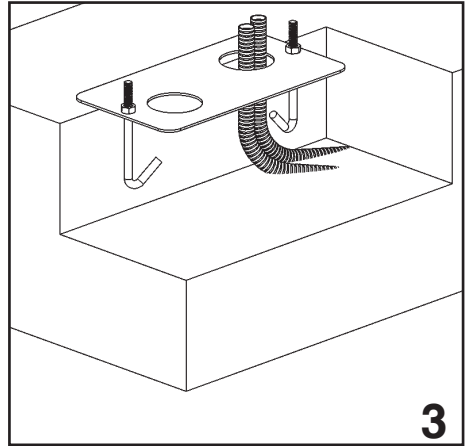
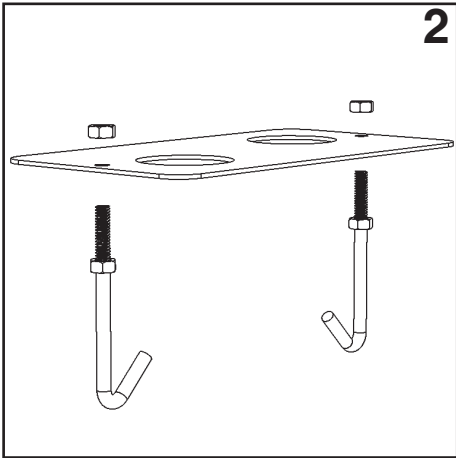
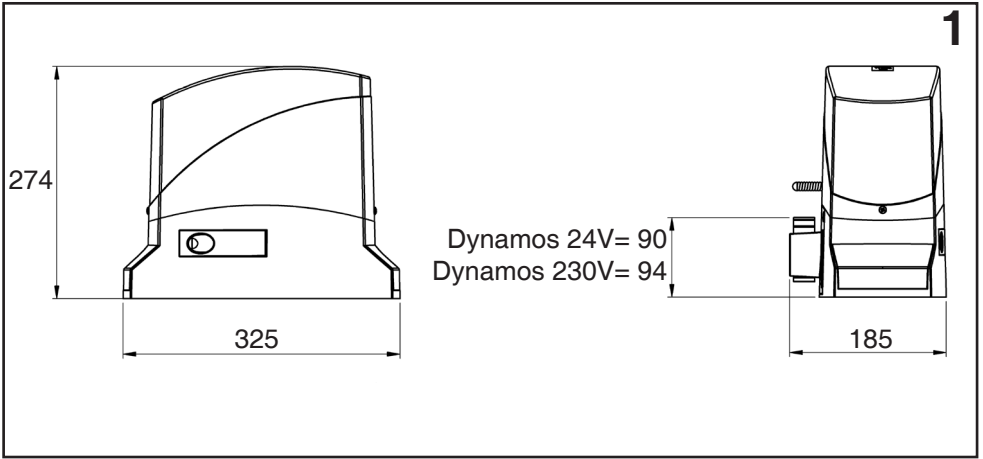

6

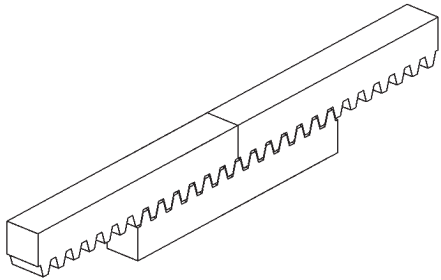

7

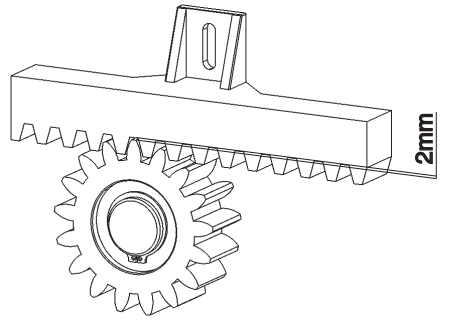

8

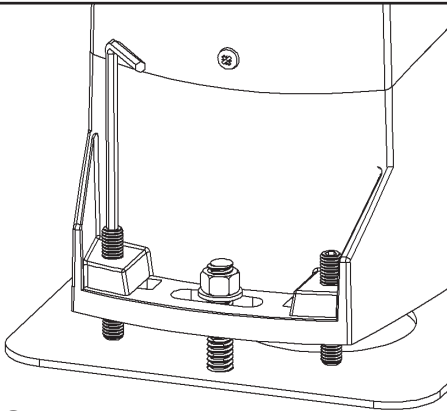

9

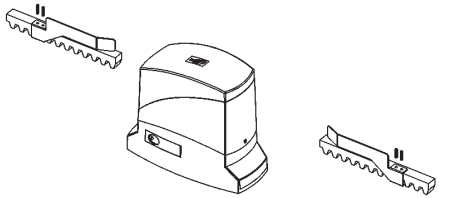

10

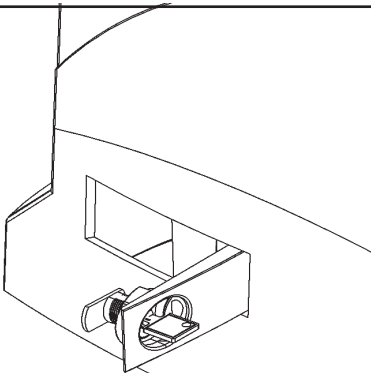

11

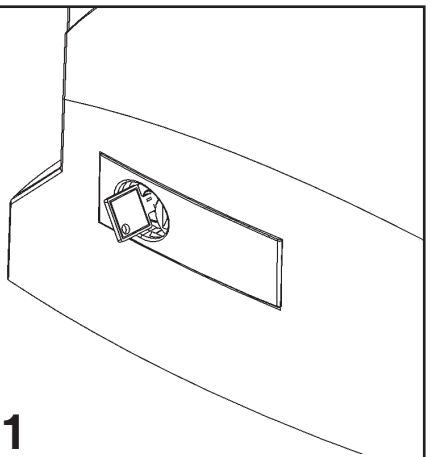

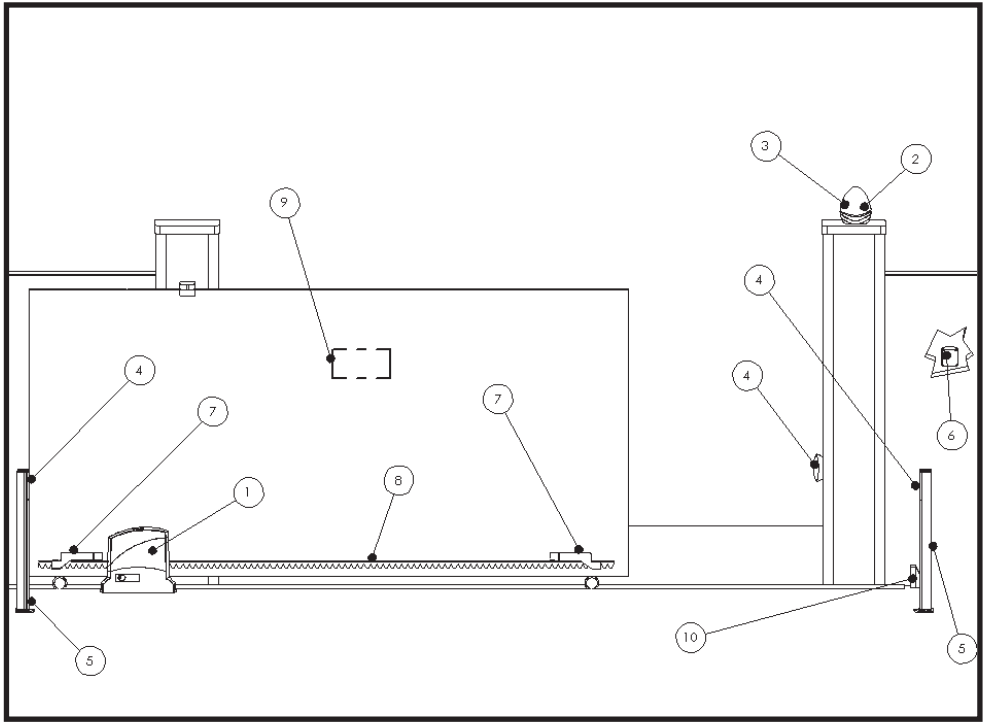

- 1- Gear-motor
- 2- Flash-light
- 3- Antenna
- 4- Photocell
- 5- Small column
- 6- Key selector
- 7- Limit switch
- 8- Rack
- 9- Warning sign
- 10- Stop locks

## ● AVAILABLE VERSIONS

<b>Code</b>	<b>Description</b>
Dynamos 500	Irreversible 230 Vac, incorporate control unit and radio receiver 433.92 Mhz, max 500 kg
Dynamos 1000	Irreversible 230 Vac, incorporate control unit and radio receiver 433.92 Mhz, max 1000 kg
Dynamos 24/400	Irreversible 24 Vdc, incorporate control unit and radio receiver 433.92 MHz, max 400kg
Dynamos 24/600	Irreversible 24 Vdc, incorporate control unit and radio receiver 433.92 MHz, max 600kg
Dynamos 24/1000	Irreversible 24 Vdc, incorporate control unit and radio receiver 433.92 MHz, max 1000kg

Before installing the product ascertain that safety conditions are observed according to the law, rules and regulation.

Use personal safety devices and locate warning signs on the motorized gate. Unfulfilment of the below listed direction will release the King gates srl, from any responsibility for damage caused to people or things.

- Ascertain the integrity of the packing when opening it.
- In case of anomalies in the functioning, turn immediatly off the gear-motor, disconnect electrical power and operate the gate manually the problem has been found and salved.
- Do not modify the product in any part.
- Only authorized and qualified staff is alloned to disassemble the product.
- Prevent any part of the automation from being next to any source of heat or in contact with liquid substances.
- Use only adequate power supply cables.
- To optimize the functioning of the automation, King gates accessories only.
- Disposal of waste material has to observe local regulations.
- Installing, testing and first functioning have to observe the laws in force.
- The gear-motor doesn't require any maintenance because provided with a permament lubrication system.

**ATTENTION:** Only authorized and qualified staff can to install the product according to the law in force.

## **PRELIMINARY CONTROL**

Before installing the product, read carefully the instructions whic provide guidelines about safety, installment, use and maintenance.

- Ascertain the solidity and appropriateness of the gate's frame.
- Ascertain the compatibility of the gate with the selected gear-motor.
- Ascertain the good balance of the gate.
- Ascertain the presence and good working condition of stopping devices.
- Ascertain that the gear-motor and the accessories are fixed on stable surfaces, protected from flooding and being hit.
- Ensure an easy and safe access to the manual release system.

- Remember to earth the power line.
- Ascertain the absence of power in pre-existent gates and remove any manual lock.
- Before the first functioning ascertain that the automation has been carried out according to the law in force.

## TECHNICAL DATA

Code	D 500	D 1000	D 24/400	D 24/600	D 24/1000
Power supply (Vac 50 Hz)	230				
Motor (Vac/Vdc)	230		24		
Motor power (W)	200	400	40	70	80
Speed (m/min.)	10		9 ÷ 15		
Overload cut-out (°C)	140		-		
Weight (kg)	10	12	9	11	
Max weight of the gate (kg)	500	1000	400	600	1000
Cycle of work (%)	30		50	80	
Dimensions (mm)	325x185x274				
Working temperature (°C)	-20 ÷ +55				

# INSTALLATION

GB

Read the instructions with care before installing the product.

The producer disclaims all responsibility for any damage or bad functioning caused by non-observance of the instructions or bad connection that may result in poor safety and functioning of the gear-motor.

## PLATE FIXING

Tighten the two foundation tie-beans on the plate with the two M10 nuts (**pic.2**)

In accordance with the size, fix the plate on a concrete base of adequate dimension, complying with fixing distances which have to be vertical and parallel to the gate.

Arrange one or more sheaths for electric cables (**pic.3**).

Once the base has hardened, loose the nuts, place the gear-motor on the foundation plate ascertaining it is parallel to the gate, and gently tighten the two nuts provided (**pic.4**).

## RACK FIXING

Set the gear-motor on manual functioning (**pic.10**).

Wide open the gate's door.

Place the rack, place the first element on the pinion and fix it with M6 screws to the gate (**pic.5**) Move the door manually and repeat the procedure with the other elements using a distance spacer to ensure the correct position from the rack (**pic.6**). It is advisable to leave 2mm between the rack the gear to avoid the gate resting on the gear-motor (**pic.7**).

## FINAL ADJUSTMENT

For the final height adjustment between the motor and the rack, use the 4 screws located on the external sides for a height up to 15mm (**pic.8**).

The final fixing of the gear-motor is done by tightening the 2 nuts placed on the foundation tie/beans.



## STOPPING STIRRUPS INSTALLING

Move the door to open/close position. Fix the left and right stop-stirrups on the rack with the screws provided, considering that when stopping, the gate slides for 2/3 cm more after the limit switch intervenes (**pic.9**).

Set the motor automatic functioning (**pic.11**).

## MANUAL CONTROL

### RELEASE

**ATTENTION:** before operating the manual release disconnect the power. The motor is anyway disconnected during the release, thanks to the presence of a safety micro-switch.

Manual control has been thought for manual opening of the gate in case of power-cut or motor breakdown.

Instruction (**pic.10**).

- Operate the manual release moving back the key hole cover.
- Insert the key in the cylinder lock and turn it of 90° clockwise direction.
- Pull the lever till it is perpendicular to the gear-motor.

### RESTORATION

Instruction (**pic.11**).

- Bring back the lever in the original position.
- Insert the key in the cylinder lock and turn it of 90° anticlockwise direction.

**ATTENTION:** the producer disclaims all responsibility for any damage or bad functioning caused by non-observance of the instructions or bad connection.