

# STAR 200

Motoriduttore per cancelli a battente  
Gear motor for hinged gates  
Motoréducteur pour portails à battants  
Motorreductor para cancelas batientes  
Antriebe für Drehtore  
Motorreductores para portões de batente  
Motoreduktor do bram skrzydłowych



# INDEX

<b>1</b>	<b>Safety warnings</b>	p. 9
<b>2</b>	<b>Product overview</b>	p. 10
2.1	Product description	p. 10
2.2	Technical characteristics	p. 10
<b>3</b>	<b>Preliminary checks</b>	p. 10
<b>4</b>	<b>Installing the product</b>	p. 11
4.1	Installation	p. 11
4.2	Electrical connections	p. 11
4.3	Setting of the mechanical limit switch while opening	p. 11
<b>5</b>	<b>Testing and commissioning</b>	p. 12
5.1	Testing	p. 12
5.2	Commissioning	p. 12
<b>6</b>	<b>Instructions and warnings for the end user</b>	p. 13
<b>7</b>	<b>Figures</b>	p. 44
<b>8</b>	<b>EC Declaration of Conformity</b>	p. 48

## 1 - SAFETY WARNINGS

**CAUTION – ORIGINAL INSTRUCTIONS - important safety instructions. Compliance with the safety instructions below is important for personal safety. Save these instructions.**

Read the instructions carefully before proceeding with installation.

**The design and manufacture of the devices making up the product and the information in this manual are compliant with current safety standards. However, incorrect installation or programming may cause serious injury to those working on or using the system. Compliance with the instructions provided here when installing the product is therefore extremely important.**

If in any doubt regarding installation, do not proceed and contact the Key Automation Technical Service for clarifications.

**Under European legislation, an automatic door or gate system must comply with the standards envisaged in the Directive 2006/42/EC (Machinery Directive) and in particular standards EN 12445; EN 12453; EN 12635 and EN 13241-1, which enable declaration of presumed conformity of the automation system.**

Therefore, final connection of the automation system to the electrical mains, system testing, commissioning and routine maintenance must be performed by skilled, qualified personnel, in observance of the instructions in the "Testing and commissioning the automation system" section.

The aforesaid personnel are also responsible for the tests required to verify the solutions adopted according to the risks present, and for ensuring observance of all legal provisions, standards and regulations, with particular reference to all requirements of the EN 12445 standard which establishes the test methods for testing door and gate automation systems.

**WARNING - Before starting installation, perform the following checks and assessments:**

ensure that every device used to set up the automation system is suited to the intended system overall. For this purpose, pay special attention to the data provided in the "Technical specifications" section. Do not proceed with installation if any one of these devices is not suitable for its intended purpose;

check that the devices purchased are sufficient to guarantee system safety and functionality;

perform a risk assessment, including a list of the essential safety requirements as envisaged in Annex I of the Machinery Directive, specifying the solutions adopted. The risk assessment is one of the documents included in the automation system's technical file. This must be compiled by a professional installer.

**Considering the risk situations that may arise during installation phases and use of the product, the automation system must be installed in compliance with the following safety precautions:**

never make modifications to any part of the automation system other than those specified in this manual. Operations of this type can only lead to malfunctions. The manufacturer declines all liability for damage caused by unauthorised modifications to products;

if the power cable is damaged, it must be replaced by the manufacturer or its after-sales service, or in all cases by a person with similar qualifications, to prevent all risks;

do not allow parts of the automation system to be immersed in water or other liquids. During installation ensure that no liquids are able to enter the various devices;

should this occur, disconnect the power supply immediately and contact a Key Automation Service Centre. Use of the automation system in these conditions may cause hazards;

never place automation system components near to sources of heat or expose them to naked lights. This may damage system components and cause malfunctions, fire or hazards;

all operations requiring opening of the protective housings of various automation system components must be performed with the control unit disconnected from the power supply. If the disconnect device is not in a visible location, affix a notice stating: "MAINTENANCE IN PROGRESS":

connect all devices to an electric power line equipped with an earthing system;

the product cannot be considered to provide effective protection against intrusion. If effective protection is required, the automation system must be combined with other devices;

the product may not be used until the automation system "commissioning" procedure has been performed as specified in the "Automation system testing and commissioning" section;

the system power supply line must include a circuit breaker device with a contact gap allowing complete disconnection in the conditions specified by class III overvoltage;

use unions with IP55 or higher protection when connecting hoses, pipes or cable glands;

the electrical system upstream of the automation system must comply with the relevant regulations and be constructed to good workmanship standards;

users are advised to install an emergency stop button close to the automation system (connected to the control PCB STOP input) to allow the door to be stopped immediately in case of danger;

this device is not intended for use by persons (including children) with impaired physical, sensory or mental capacities, or with lack of experience or skill, unless a person responsible for their safety provides surveillance or instruction in use of the device;

before starting the automation system, ensure that there is no-one in the immediate vicinity;

before proceeding with any cleaning or maintenance work on the automation system, disconnect it from the electrical mains;

special care must be taken to avoid crushing between the part operated by the automation system and any fixed parts around it;

children must be supervised to ensure that they do not play with the equipment.

**WARNING - The automation system component packaging material must be disposed of in full observance of current local waste disposal legislation.**

**WARNING - The data and information in this manual are subject to modification at any time, with no obligation on the part of Key Automation S.r.l. to provide notice.**

## 2 - PRODUCT OVERVIEW

### 2.1 - Description of the product

The STAR gear motors are destined to be installed in systems for the automation of gates with hinged doors.

The STAR gear motors have been designed and constructed to be fitted onto hinged doors within the weight limits indicated in the technical specifications table.

The use of gear motors for applications which differ from those indicated above is prohibited.

The use of gear motors for applications which differ from those indicated above is prohibited.

### 2.2 - Technical characteristics

#### TECHNICAL DATA

MODELS		STAR2024
TECHNICAL SPECIFICATIONS		
Speed	cm/s	20
Thrust Force	N	1400
Working cycle	%	80
Opening time at 90°	sec	adjustable
Control unit		14AB
Power supply	Vac (Vdc)	(24)
Absorption	A	3,5
Engine power	W	85
Degree of protection	IP	54
Dimensions (L - P - H)	mm	646 - 115 - 177
Weight	Kg	3
Operating temperature	°C	-20°+55
Leaves maximum weight	Kg	400

## 3 - PRELIMINARY CHECKS

Before installing this product, verify and check the following steps:

- Check that the gate or door are suitable for automation
- The weight and size of the gate or door must be within the maximum permissible operating limits specified in Fig. 2
- Check the presence and strength of the security mechanical stops of the gate or door
- Check that the mounting area of the product is not subject to flooding
- Conditions of high acidity or salinity or proximity to heat sources could cause malfunction of the product
- Extreme weather conditions (for example the presence of snow, ice, high temperature range, high temperatures) may increase the friction and therefore the force required for the handling and initial

starting point may be higher than under normal conditions.

- Check that the manual operation of gate or door is smooth and friction-free and there is no risk of derailment of the same
- Check that the gate or door are in equilibrium and stationary if left in any position
- Check that the power line to supply the product is equipped with proper grounding safety and protected by a magnetothermal and differential security device
- Provide the power system with a disconnecting device with a gap of contacts enabling full disconnection under the conditions dictated by the overvoltage category III.
- Ensure that all materials used for the installation comply with current regulations

## 4 - PRODUCT INSTALLATION

### 4.1 - Installation

Before proceeding with the installation, check the integrity of the product and that all components are present in the package. Also make sure that the mounting area of the gear motor is compatible with the dimensions (Fig.1). Check the permitted opening angle, based on the mounting points of the brackets with the graph (Fig.4).

Fig.3 shows a typical installation:

- Gear motors
- Photocells
- Columns for photocells
- Flashing light with antenna
- Key switch or digital keypad
- Control unit

#### Installing the rear fixing bracket

The fixing position of the rear bracket is determined according to the graph (Fig. 4). Important: installations where the values of "A" and "B" (Fig. 5) are as

similar to each other as possible are preferred.

If necessary, cut the rear bracket (Fig. 6) to obtain the value "B", then weld the fixing bracket to the wall.

Secure the bracket to the wall using welding, screws or bolts (not included).

#### Installing the front fixing bracket

The front bracket must be fixed to the door according to dimension "E" (Fig.5).

#### Installing the gear motor

Place the gear motor against the rear bracket and insert the fixing screw.

Insert the pin of the sliding bracket into the bush of the front bracket and secure it with the screw and washer provided.

Tighten the screw on the rear bracket previously mounted with the nut.

### 4.2 - Electrical connections

Insert the supply cable to the terminal. Connect the wires of the supply cable to the terminal following the electrical drawing in Fig. 9.

## 5 - TESTING AND COMMISSIONING THE AUTOMATION

The testing of the system must be performed by qualified technicians who must perform the tests required by relevant legislation related to risks, ensuring compliance with the provisions of the

regulations, in particular the EN12445 standard, which specifies the testing methods for the automation of doors and gates.

### 5.1 Testing

All system components must be tested following the procedures outlined in the respective instruction manuals.

Check that they meet the guidelines in Chapter 1 - Safety warnings  
Check that the gate or door can move freely once the automation is unlocked, and that they are in equilibrium and stationary if left in any position.

Check the correct operation of all connected devices (photocells, sensitive edges, emergency buttons, etc.), testing the opening, closing and stopping of the gate or door via the connected control devices (transmitters, buttons, switches).

Carry out measurements of the impact force, as prescribed by standard EN12445 adjusting the functions of speed, motor force and deceleration of the unit if the measurements do not give the desired results until you find the right setting.

### 5.2 Commissioning

Following the successful testing of all (and not just some) devices in the system you can proceed with the commissioning.

You must prepare, and keep for 10 years, the technical file of the system with the wiring diagram, drawing or photo of the system, risks analysis and solutions adopted, manufacturer declaration of conformity of all devices connected, instruction manual of each device and maintenance schedule of the system.

Fix on the gate or door a plaque indicating the automation data, the name of the person responsible for the commissioning, the serial number and year of construction, the CE mark.

Attach a plaque indicating the steps required to manually unlock the system.

Implement and deliver to the end user the declaration of conformity, the instructions and warnings for use for the end user and the maintenance schedule of the system.

Make sure the user understands proper automatic, manual and emergency operation of the automation.

Inform the end user in writing of the dangers and risks still present.

## 6 - INSTRUCTIONS AND WARNINGS FOR THE END USER

Key Automation S.r.l. produces systems for the automation of gates, garage doors, automatic doors, shutters, parking lots and road barriers. However, Key Automation is not the manufacturer of your automation system, which is rather the result of a process of analysis, evaluation, selection of materials, and installation performed by your own installer. Each automated system is unique and only your installer has the experience and professionalism required to create a system to suit your needs, safe and reliable over time, and carried out in a workmanlike manner, i.e. compliant with the current regulations. Even if your automation system meets the security level required by law, this does not exclude the existence of "residual risks", i.e. the possibility that it may cause dangerous situations, usually as a result of improper or irresponsible use; for this reason we would like to give you some suggestions:

- Before using the automation for the first time, ask the installer to explain the origin of residual risks.
- Keep this manual for future use and deliver it to any new owner of the automation.
- Inappropriate or improper use of the automation can make it dangerous: do not command the movement of the automation if people, animals or things are in its range.
- Children: If properly designed, an automation system ensures a high degree of security, preventing movement in the presence of people or things with its detection systems, and ensuring always predictable and safe activation. It is prudent to prevent children from playing near the automation and keep remote controls out of their reach to prevent accidental activation.
- Malfunctions: As soon as you notice any malfunctions, disconnect the system from the power supply and operate the manual release. Do not attempt any repairs by yourself, but require the assistance of your installer: meanwhile, the system can operate like a non-automated opening device after releasing the motor reducer with the release key supplied with the system.
- In case of failures or power failures: While awaiting the arrival of your installer or the restore of the electricity, if the system is not equipped with backup batteries, the automation can be operated as any normal non-automated opening device. To do this, you must run the manual release.

Release and manual movement: before performing this operation pay attention that the device can be released only when the door is stationary.

- Maintenance: Like any machine, your automation needs periodic maintenance to ensure its long life and total safety. Agree with your installer on a maintenance plan on a periodic basis; Key Automation recommends a frequency of 6 months for normal domestic use, but this period may vary depending on the intensity of use. All inspection, maintenance or repairs should be performed only by qualified personnel.

- Do not change the system and control or programming parameters of the automation: the responsibility lies with your installer.

- The testing, routine maintenance and any repairs must be documented by the person who performs them, and related documents must be kept by the owner.

The only interventions that are possible for the user and should be carried out periodically are the cleaning of the slides and photo-cells, as well as the removal of any leaves or rocks that could hinder the automation. To prevent anyone from activating the gate or door, before proceeding, remember to release the automation and clean only with a cloth slightly dampened with water.

- Disposal: At the end of the automation useful life, make sure that the dismantling is carried out by qualified personnel and the materials are recycled or disposed of according to local regulations in force.

- Operate the gate or door (with remote control, key switch, etc.); if everything is working properly, the gate or the door will open and close normally, otherwise the flashing light flashes and the maneuver does not start.

With the safeties out of use, the automation must be repaired as soon as possible.

Replacing the remote control battery: if your remote control seems to work worse or not work at all after a while, this may simply depend on the exhaustion of the battery (depending on use, it may take several months to over a year). In that case, you will see that the confirmation of transmission light does not turn on, or comes on only briefly.

The batteries contain polluting substances: do not throw them in the garbage but use the methods prescribed by local regulations.

Thank you for choosing keyautomation; for more information feel free to visit our website [www.keyautomation.it](http://www.keyautomation.it).

## IMAGES

**Fig. 1 IT - Dimensioni d'ingombro**  
 EN - Space dimensions  
 DE - Abmessungen  
 ES - Dimensiones

FR - Dimensions d'encombrement  
 PT - Dimensões globais  
 PL - Wymiary

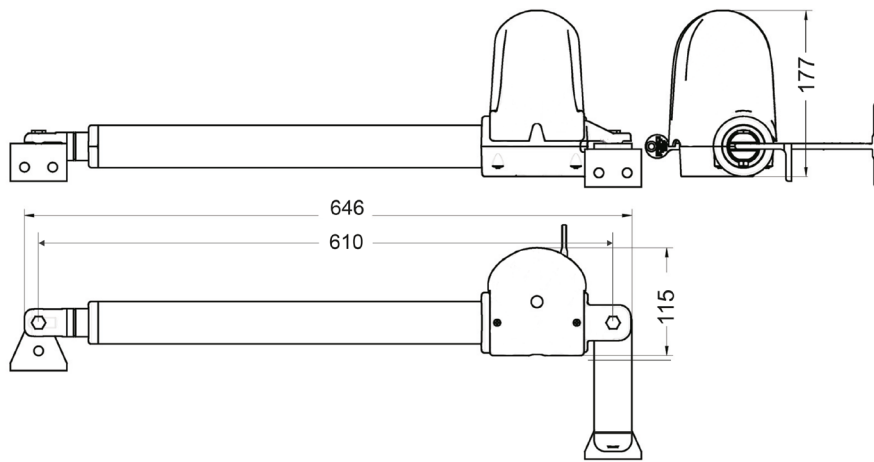

**Fig. 2 IT - Limiti di impiego**  
 EN - Use limitations  
 DE - Einsatzgrenzen  
 ES - Límites de uso

FR - Limites d'utilisation  
 PT - Limites de uso  
 PL - Ograniczenia użytkowania

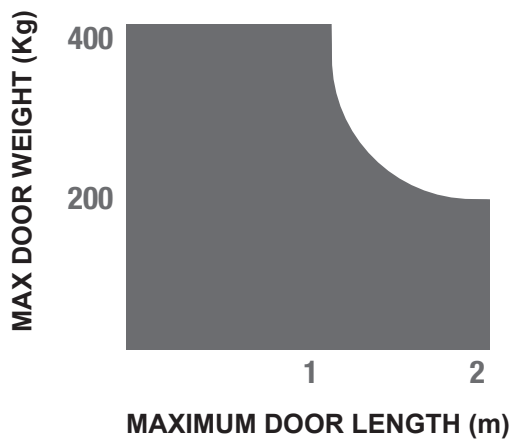

KG

IT - Peso massimo dell' anta del cancello  
 EN - Maximum weight of the gate door  
 FR - Poids maximum du battant du portail  
 ES - Peso máximo de la puerta de la cancela  
 DE - Maximales Gewicht des Torflügels  
 PT - Peso máximo do painel do portão  
 PL - Waga maksymalna skrzydła bramy

m  
 IT - Lunghezza massima dell' anta del cancello  
 EN - Maximum length of the gate door  
 FR - Longueur maximum du battant du portail  
 ES - Longitud máxima de la puerta de la cancela  
 DE - Maximale Länge des Torflügels  
 PT - Comprimento máximo do painel do portão  
 PL - Długość maksymalna skrzydła bramy

**Fig. 3 IT - Installazione tipica**  
 EN - Typical Installation  
 DE - Typische Installation  
 ES - Instalación típica

FR - Installation type  
 PT - Instalação típica  
 PL - Typowy sposób instalacji

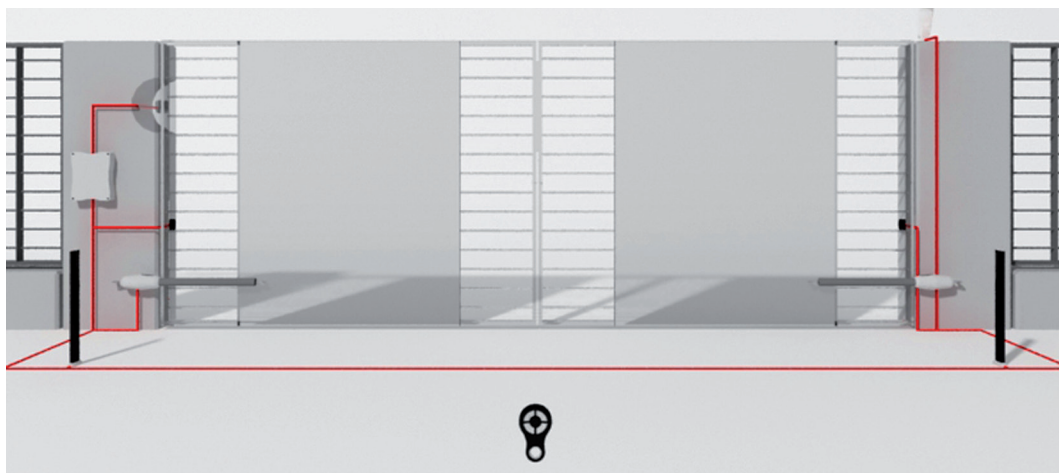



Fig. 4 IT - Rappresentazione quote  
 EN - Quotes representation  
 DE - Darstellung der Werte  
 ES - Representación cuotas

FR - Représentation hauteurs  
 PT - Quotas de representação  
 PL - Przedstawienie wartości

	OPENING ANGLE C									
B / A	80	100	120	140	160	180	200	220	240	260
100	92	101	109	116	122	120	109	103	98	94
120	91	99	106	113	118	111	103	97	93	90
140	90	97	104	110	115	103	97	92		
160		96	102	108	104	96	91			
180		95	101	106	95	90				
200		94	99	94						
220		93	93							
240		92								

	POSITION FRONT CLAMPS D									
B / A	80	100	120	140	160	180	200	220	240	260
100	712	727	744	761	779	785	765	745	725	705
120	730	744	758	774	791	784	764	744	724	704
140		761	774	789	803	783	763	743		
160		779	791	804	802	782	762			
180		797	808	820	800					
200		815	825	818						
220		834	835							
240		852								

	TOTAL EXTENSION E									
B / A	80	100	120	140	160	180	200	220	240	260
100	792	827	864	901	939	965	965	965	965	965
120	811	844	879	915	951	965	965	965	965	965
140		863	896	930	965	965	965	965		
160		882	914	947	965	965	965			
180		902	933	965	965					
200		923	953	965						
220		945	965							
240		965								

Fig. 5 IT - Grafico angolo di apertura  
 EN - Opening angle graph  
 DE - Zeichnung zum Öffnungswinkel  
 ES - Gráfico ángulo de apertura

FR - Graphique angle d'ouverture  
 PT - Gráfico ângulo de abertura  
 PL - Wykres kąta otwarcia

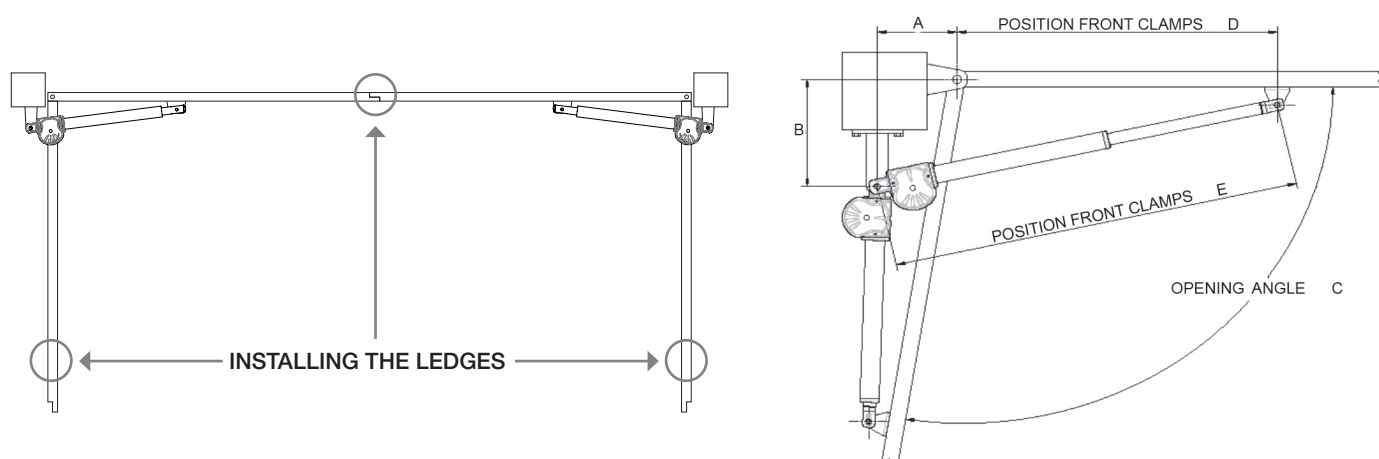

**Fig. 6 IT - Taglio staffa posteriore**  
 EN - Cutting the rear bracket  
 DE - Schneiden des hinteren Bügels  
 ES - Corte estribo posterior

FR - Coupe du chevron arrière  
 PT - Tamanho suporte posterior  
 PL - Przecięcie obejm tylny

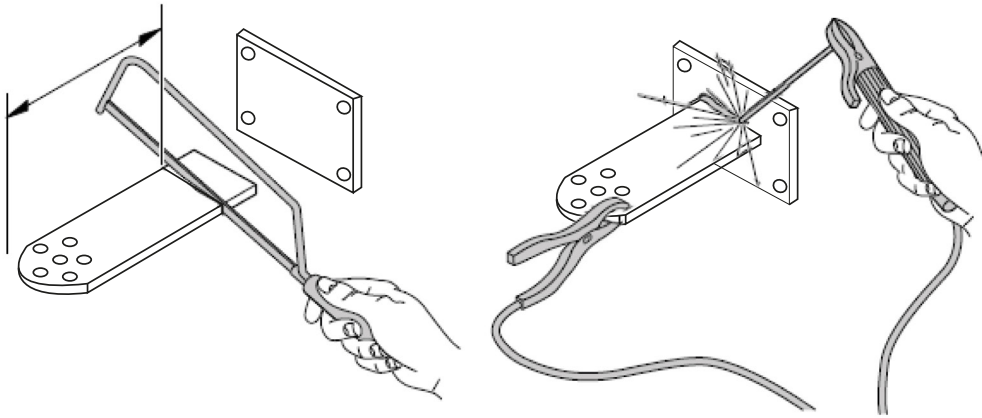

**Fig. 7 IT - Fissaggio staffa anteriore**  
 EN - Attaching the front bracket  
 DE - Befestigung des vorderen Bügels  
 ES - Fijación del estribo anterior

FR - Fixation du chevron avant  
 PT - Fixação suporte anterior  
 PL - Mocowanie obejmi przedniej

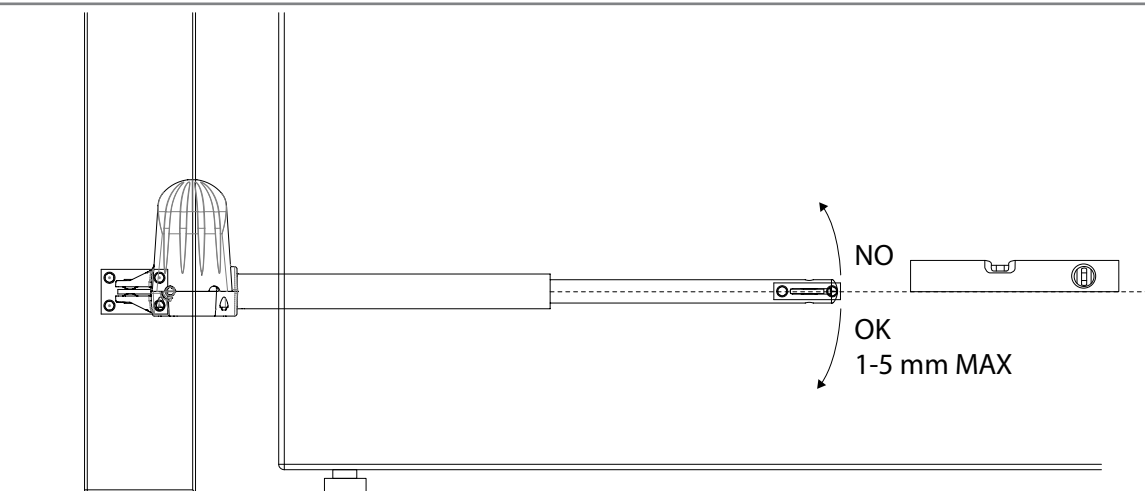

**Fig. 8 IT - Sblocco del motoriduttore**  
 EN - Gearmotor release  
 DE - Entriegeln des Getriebemotors  
 ES - Desbloqueo del motorreductor

FR - Déblocage du motoréducteur  
 PT - Desbloqueio do motorreductor  
 PL - Odblokowanie motoreduktora

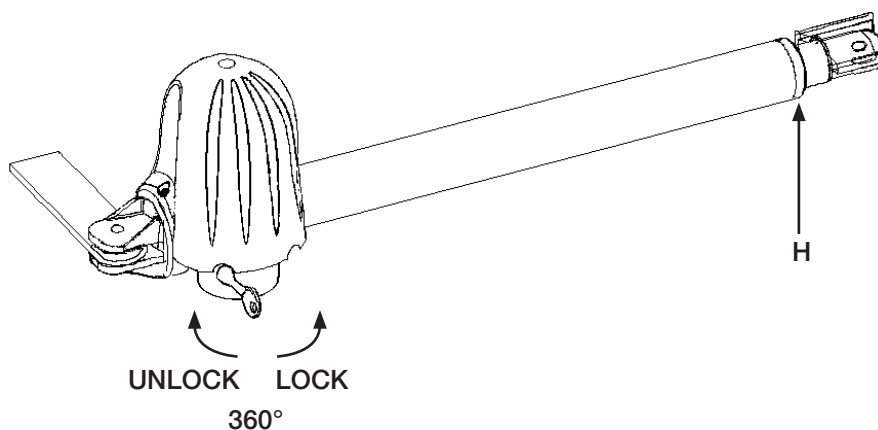
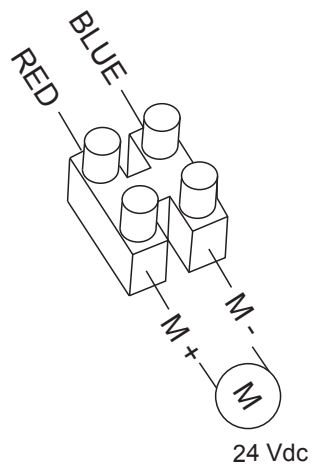

Fig. 9 IT - Conessioni elettriche  
EN - Electrical connections  
DE - Elektrische Anschlüsse  
ES - Conexiones eléctricas

FR - Connexions électriques  
PT - Conexões eléctricas  
PL - Połączenia elektryczne



## DICHIARAZIONE DI INCORPORAZIONE DI QUASI-MACCHINA

### DECLARATION OF INCORPORATION OF PARTLY COMPLETED MACHINERY

Il sottoscritto Nicola Michelin, Amministratore Delegato dell'azienda  
*The undersigned Nicola Michelin, General Manager of the company*

Key Automation srl, Via Alessandro Volta, 30 - 30020 Noventa di Piave (VE) – ITALIA

dichiara che il prodotto tipo:  
*declares that the product type:*

#### **STAR 24**

Motoriduttore elettromeccanico irreversibile 24Vdc a pistone per cancelli battenti  
*Electromechanical irreversible 24Vdc piston for swing gates*

Models:  
*Models:*

900STAR2024, STAR2024DX, STAR2024SX  
900PS400-24FA

E' conforme a quanto previsto dalle seguenti direttive comunitarie:  
*Is in conformity with the following community (EC) regulations:*

Direttiva macchine / *Machinery Directive 2006/42/EC*  
Direttiva compatibilità elettromagnetica / *EMC Directive 2004/108/EC*

Secondo quanto previsto dalle seguenti norme armonizzate:  
*In accordance with the following harmonized standards regulations:*

EN 55014-1:2006 + A1:2009 + A2:2011  
EN 55014-2:1997 + A1:2001 + A2:2008  
EN 61000-3-2 + EN 61000-3-3  
EN 61000-6-1 + EN 61000-6-2 + EN 61000-6-3 + EN 61000-6-4  
EN 62233:2008

Dichiara che la documentazione tecnica pertinente al prodotto è stata redatta conformemente a quanto previsto dalla direttiva 2006/42/CE Allegato VII parte B e verrà fornita a fronte di una richiesta adeguatamente motivata dalle autorità nazionali.

*Declares that the technical documentation is compiled in accordance with the directive 2006/42/EC Annex VII part B and will be transmitted in response to a reasoned request by the national authorities.*

Dichiara altresì che non è consentita la messa in servizio del prodotto finché la macchina, in cui il prodotto è incorporato, non sia stata dichiarata conforme alla direttiva 2006/42/CE.

*He also declares that is not allowed to use the above mentioned product until the machine, in which this product is incorporated, has been identified and declared in conformity with the regulation 2006/42/EC.*

Noventa di Piave (VE), 05/08/14

Amministratore Delegato  
*General Manager*  
Nicola Michelin



Key Automation S.r.l.  
Via A. Volta, 30  
30020 Noventa di Piave (VE)  
P.IVA 03627650264 C.F. 03627650264  
[info@keyautomation.it](mailto:info@keyautomation.it)

Capitale sociale 1.000.000,00 i.v.  
Reg. Imprese di Venezia 03627650264  
REA VE 326953  
[www.keyautomation.it](http://www.keyautomation.it)



Organizzazione con sistema di gestione certificato  
ISO 9001:2008

# NOTE

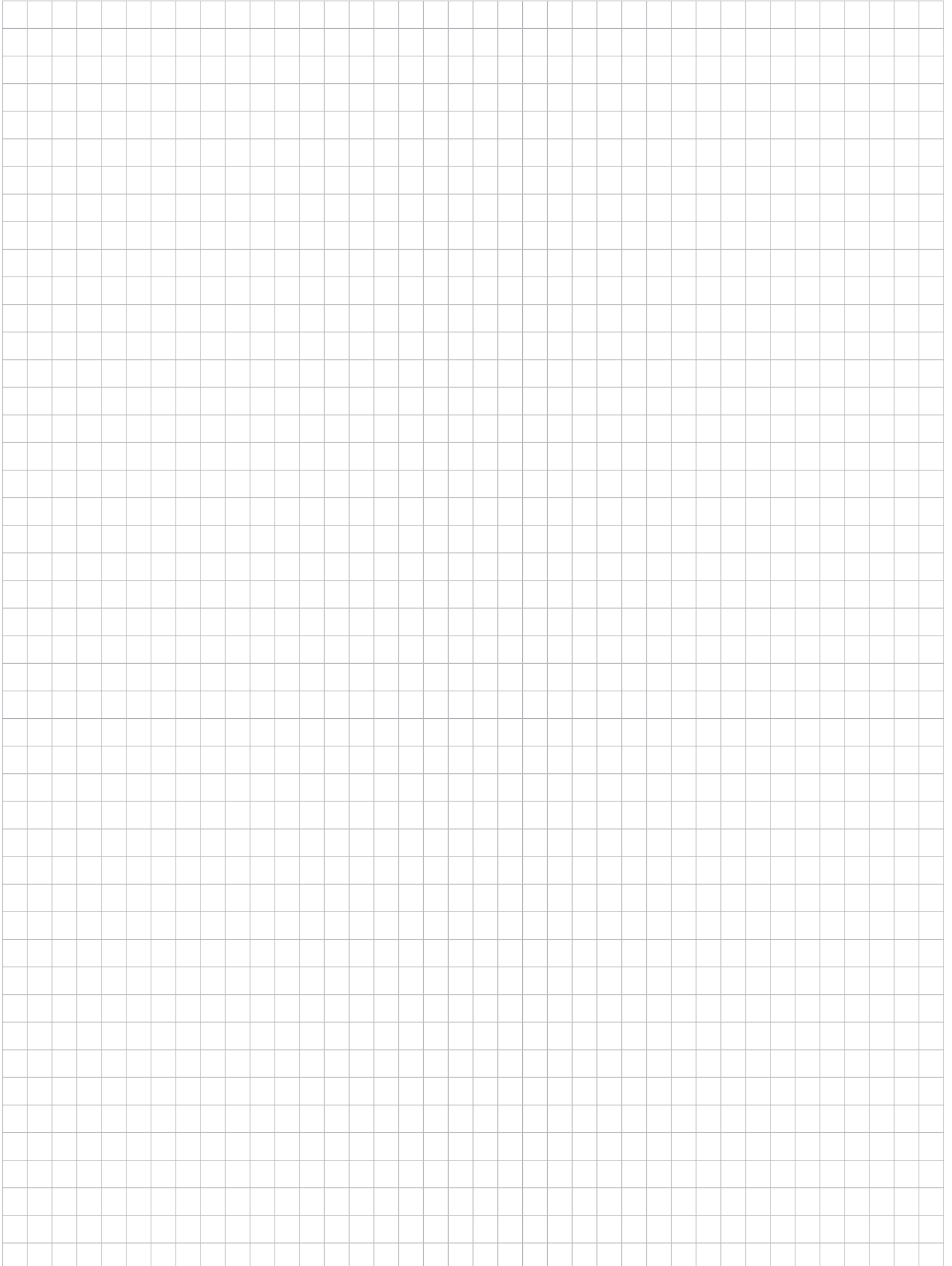



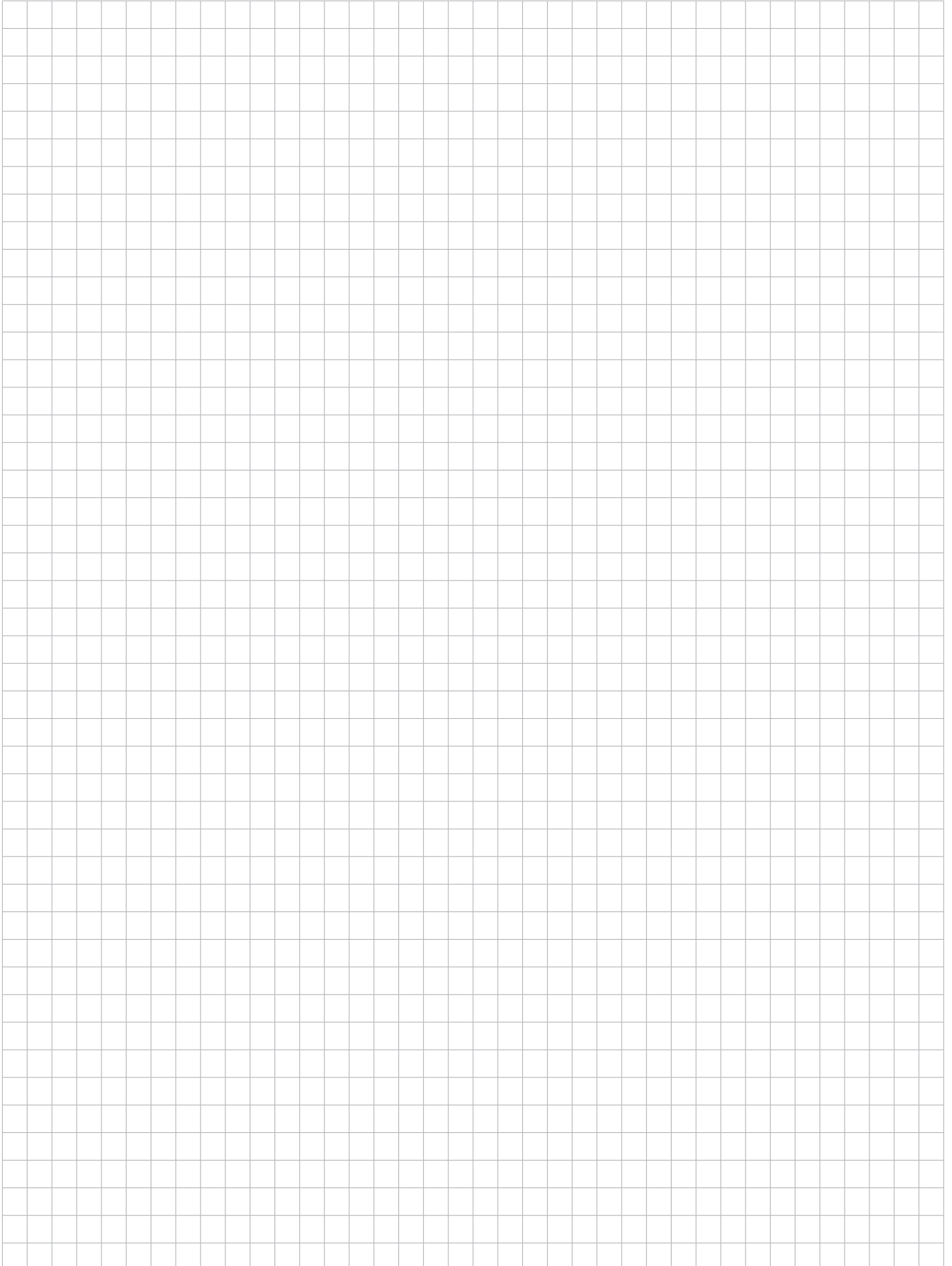

**Key Automation**

Via A. Volta 30 - 30020 Noventa di Piave (VE)

T. +39 0421.307.456 - F. +39 0421.656.98

info@keyautomation.it - www.keyautomation.it

Instruction version  
580ISSTAR200 REV.02