

PROUD MANUFACTURERS & SUPPLIERS OF:

SLIDE GATE OPERATORS:

- COMPACT 300
- COMPACT 500
- SOLO
- CONDO
- CONDO AC/DC

SWING GATE OPERATORS:

- DURASWING

GARAGE DOOR OPERATORS:

- LAZER SECTIONAL
- LAZER ROLL UP
- LAZER VERTICAL ROLL UP
- LAZER TIP UP

TRANSMITTER & RECEIVERS:

- DURATRONIC 2; 3; 4 & 6 BUTTON REMOTES
- DURATRONIC On-BOARD & EXTERNAL RECEIVERS

SAFETY BEAMS:

- DURAOPTICS

VEHICLE DETECTION LOOP:

- DURALOOP



DURASWING GATE OPERATORS

INSTALLATION AND OWNERS MANUAL



INDEX

INTRODUCTION _____	P3
LEGAL REQUIREMENTS _____	P3
SPECIFICATIONS _____	P3
GENERAL INFORMATION _____	P4
TERMS AND DEFINITIONS _____	P4
GENERAL SITE LAYOUT _____	P5
GENERAL OPERATOR LAYOUT _____	P6
MAIN PC BOARD LAYOUT _____	P7
ELECTRICAL WIRING _____	P7
TRANSFORMER (POWER SUPPLY) _____	P8
MOUNTING THE OPERATORS _____	P9
PEDESTAL MOUNT _____	P10
<i>INWARD SWING</i> _____	P11
<i>OUTWARD SWING</i> _____	P12
<i>PANHANDLE</i> _____	P13
WALL MOUNT _____	P14
<i>INWARD</i> _____	P14
<i>OUTWARD</i> _____	P15
WIRING THE SLAVE OPERATOR _____	P16
SETTING THE LIMITS _____	P17-18
PROGRAMMING & ERASING REMOTES _____	P19
PC BOARD CONNECTIONS _____	P20
DIPSWITCH SETTINGS _____	P21
LED FUNCTIONS _____	P22
OTHER FUNCTIONS _____	P23
CONNECTING AUXILIARY EQUIPMENT _____	P24-29
CONNECTING A SOLAR PANEL _____	P30
WARRANTY & FAULT FINDING _____	P31

WARRANTY

D.A.C.E. offers a Factory Warranty on this equipment. The following terms and conditions apply to ALL warranty claims.

D.A.C.E. warrants the **ORIGINAL** purchaser, at the point of sale, that the product is in good working order and is free from any defect.

ANY warranty claim **must** be accompanied by the **original** invoice.

The original purchaser is responsible for checking that the equipment is free from any visible defect before it leaves the point of sale.

The warranty period is **24 months** from date of **MANUFACTURE**.

The warranty is a **“walk in “**warranty. **No** warranty claim will be entered into **“on site”**.

The equipment must be returned to the factory with the original invoice for any repair or replacement. The **transport** cost is for the end **users account**.

If the equipment was purchased at a dealer, merchant or agent of D.A.C.E. the claim must be directed to said merchant, dealer etc.

The warranty will **not cover** any of the following circumstances in any way.

- **Incorrect installation of the equipment.**
- **Incorrect wiring of the equipment.**
- **Lightning, flooding, power-surge, fire, corrosion, insect infestation or any form of abnormal use of the equipment.**

NOTE: the **transformer is not guaranteed** in any manner, due to power fluctuations.

Any warranty claim must be inspected and tested by a D.A.C.E. representative before any further claim is entered into.

FAULT FINDING

FAULT	REASON	ACTION
One gate does not operate at all or operates erratically.	Motor fuse (8 amp) blown or micro switch faulty.	Replace 8 amp fuse or replace micro switch.
Gates stop when closing and then re-open automatically.	Over current/ gate jamming.	Check gate / hinges / conrod / crank arm & any other possible obstruction. Decrease sensitivity on close POT.
Gates opens without any trigger input. (opens on its own)	Motor wires are the wrong way & Auto-close function is activated.	Change motor direction.
Gates are jammed and will not move at all.	General shut down.	Remove all power and reconnect power.
Gates do not operate from the remote but will operate using the test button on the PC Board.	Receiver faulty or loose wire connection or 3 amp fuse blown on PC Board.	Tighten wires, replace fuse or replace receiver. Disconnect power for 2 minutes to allow fuse to reset.

CONNECTING A SOLAR PANEL

A REGULATOR IS NOT REQUIRED WHEN CONNECTING A SOLAR PANEL

SOLAR PANEL
(min 20 Watts)

An external regulator is NOT required when connecting a solar panel. Ensure that the panel does NOT exceed the min and max specifications.

Solar Panel Specifications:

- **Min output voltage 16.5 VDC**
- **Max output voltage 21 VDC**
(an output voltage below 16.5 VDC will not charge the internal battery).

Connect the solar panel wires to the 16 VAC plug on the main PC Board.
(Wire polarity is not important)

16 VAC connector from transformer

Negative wire (-)

Positive wire (+)

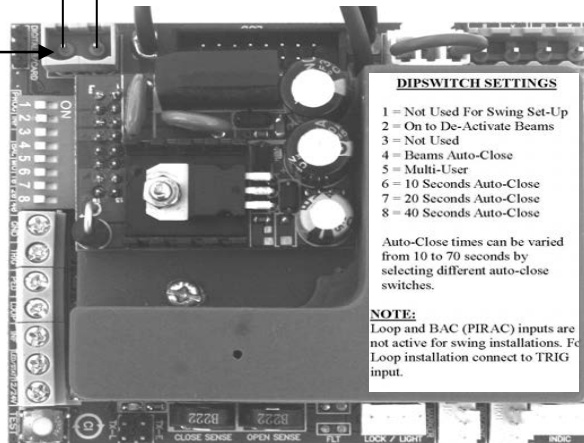

INTRODUCTION AND RECOMMENDATIONS

Congratulations on purchasing your **DURASWING** gate operators. D.A.C.E has proven to be a leader in the automation field and strives to manufacture high quality products using the latest technology available. D.A.C.E is constantly working on upgrading their products to bring you, the customer, a product of the highest quality. Other products manufactured include:

- Slide gate operators - SOLO; CONDO; CONDO AC/DC; COMPACT 300 & 500
- Infrared beams - DuraOptics
- Remotes & receivers - DuraTronic
- Vehicle detection loop - DuraLoop

It is recommended that an experienced gate installer is used to install your gate operator. If you intend to install this operator yourself, please read this manual carefully before any installation begins.

It is strongly recommended that **DuraOptics** safety beams are used on all installations, as this reduces the risk of the gate closing on a pedestrian or vehicle.

It is also recommended that a theft deterrent bracket is installed to deter any tampering with the operator.

NOTE : D.A.C.E. supplies an on-board receiver with every operator. D.A.C.E. cannot guarantee the range of the receiver due to interference or obstacles in the path of the receiver. Should more range be required, it is recommended that an external **DuraTronic** receiver be used.

This automatic gate operator is **NOT** a security device. It is designed to make access to a premises undemanding.

LEGAL REQUIREMENTS AND WARNINGS

- It is recommended that your local E.C.A. (Electrical Contractors Association) is contacted in order to obtain the legal wiring regulations pertaining to the area.
- Electrical Shock may occur while installing this equipment.
- Injury or death by electrocution may lead to law suits against the installer/homeowner.
- If you intend to run 230V directly from the Mains supply (house supply) to the transformer, the wiring should be done by a qualified/registered electrician. This is a legal requirement and failure to do so may lead to non-compliance of property or law suits against the property owner in the event of an accident.
- It is a legal requirement to run all cabling in conduit. The power supply must be run in a separate conduit to ANY other cables.
- Mains supply may only be run in a guarded cable. Under no circumstances may 230V be run using Communication cable, Ripcord or Cabtyre.
- D.A.C.E will not be held liable for any accident / incident resulting in damage, injury or death ensuing from the installation of the automatic gate operator.
- Although the DURASWING operators have built-in collision sensing, substantial damage may still occur. For this reason safety beams should be used on all installations.
- Do not allow children to play near or with any gate, gate operator or remote control.
- It is the responsibility of the installer to ensure that the gate is in good working condition before automating the gate.
- This D.A.C.E. operator is supplied with a 16 VAC transformer. This transformer should be plugged into a normal plug socket. **DO NOT** open the transformer.

SPECIFICATIONS

Motors	_____	12v/dc (battery operated with charging system)
Maximum gate size	_____	2,5 m per leaf
Maximum gate mass	_____	100 kg per leaf
Maximum number of operations	_____	100 per day
Maximum operating degrees	_____	110 (recommended 90 degrees)

SPECIFICATIONS cont.

Charging system _____	16 VAC transformer and 600mA 13.4 v/dc trickle charger.
Battery _____	12v/dc 7 amp/hour
Limit detection _____	Mechanical micro switch
Trigger _____	Negative

GENERAL INFORMATION

Before installing these **DURASWING** operators please read the following:

There are a number of different methods of installing swing gate operators. The main factors that influence the installation are as follows.

- **Direction the gate/s swing:**

Inward swing method — the gates are pulled open towards the operators.

Outward swing method — the gates are pushed open away from the operators.

The above two methods are normally determined by the type of gate and / or slope of the driveway.

- **Mounting method:**

Pedestal mount — a steel pedestal is buried in the ground and the operator is mounted on top of the pedestal.

Wall mount — a steel wall mount bracket is bolted to the wall / pillar and the operator is mounted on to the bracket.

Before installation begins the gates must be in good working order. Check the following points and rectify if not in order before installing the operators:

- The gates must swing easily ie the gate must swing through the full arc using the force of two fingers only.
- The gate posts must be solid and the hinges must be in good working order.
- Ensure the gates comply with the operator specifications.

NOTE: Fully clad wooden or fibreglass gates can be problematic in windy conditions.

TERMS AND DEFINITIONS

- **Auto-close:** allows gate to close automatically after a selected time period.
- **Pedestrian access:** allows only partial opening of the gate and will auto-close after 6 seconds.
- **Party mode:** this allows autoclose to be overridden as required.
- **Multi-user mode:** commonly used in a town house/complex situation. The gate will open completely, regardless of any other trigger received to prevent accidental closure.
- **Collision sensing:** in the event of a collision while closing, the gate will stop and then re-open. If collision occurs while opening, the gate will stop.
- **Battery:** 12 volt 7 amp/hour, operates the operator.
- **Charger module:** the on-board charger receives 16 VAC from the transformer and then delivers a trickle charge to maintain \pm 13.4 VDC charge to the battery.
- **Transformer:** the transformer reduces the mains power (230V) to 16 VAC. **NOTE!** The cable to be used from the transformer to the main PC board must be a minimum of 1.5mm cable. DO NOT use communications cable.
- **Main PC Board:** this is the printed circuit board that contains all the electronic components that operate the operator. **NOTE!** Always remove the power from the PC board before connecting any out-put wires.
- **Receiver:** receives a signal from the transmitter and triggers the operator.
- **Remote/Transmitter:** usually a hand held product which transmits a signal to the receiver.
- **Intercom:** there are many types of intercoms available. An intercom allows communication between the gate and the house. Most intercoms have trigger buttons to operate the gate.
- **Test button:** found on the main PC Board and is used to activate the operator. Used during the programming of the operator.
- **Limit switch:** stops the operator when the rotor activates the switch.
- **Limit switch rotor:** is a cam shaped rotor that is connected to the main shaft. The rotor turns with the shaft and activates the limit switch in order to stop the operator.

4

CONNECTING AN EXTERNAL STATUS LED

An external status LED can be connected to the main PC Board. This LED will indicate the status of the gate. The LED can be fitted to the intercom or any other convenient place.

CONNECTOR BLOCK ON MAIN PC BOARD

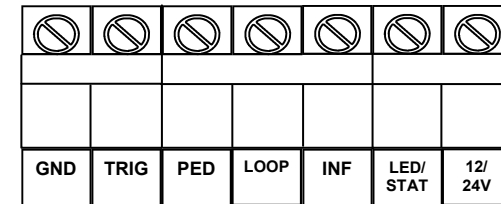

5mm leaded LED

CONNECTING A VEHICLE DETECTION LOOP ON A SWING GATE OPERATOR

A vehicle detection loop is used to automatically open the gates when a vehicle approaches (most commonly in the exit direction). The following instructions are for a DuraLoop Vehicle Detector. Note that whatever product is used it is important to follow the manufacturers installation instructions as these may differ from one product to another.

It is extremely important that the loop is placed in such a way that the vehicle that triggers the loop is not in any way within the opening arc of the gates as this will cause damage to the vehicle if the gates strike the vehicle.

Number 5 dipswitch (Multi User) must be ON when using a loop vehicle detector. This will avoid a second vehicle triggering the gates closed.

CONNECTOR BLOCK ON MAIN PC BOARD

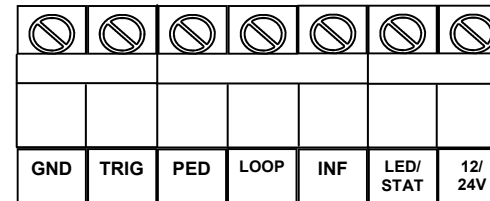

PLEASE NOTE: LOOP input is used for slide operators ONLY!!

Twisted feeder cable to driveway

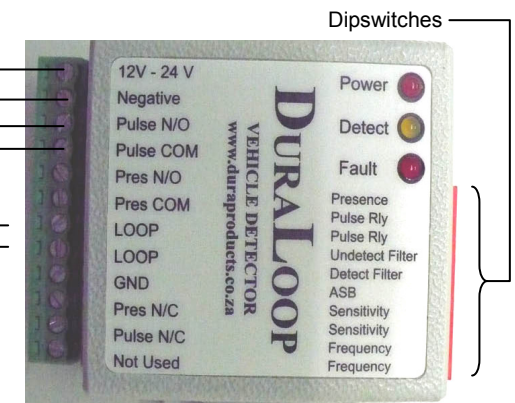

**CONNECTING A MAGNETIC OR STRIKE TO THE LOCK/LIGHT RELAY BOARD -
(SINGLE SWING ONLY SA038)**

The Light /Lock card (SA038) is designed to operate pillar lights or a magnetic or strike lock (lock used on single swing gates only). The pillar lights will remain on for four minutes after activation. So too a toggle switch can be connected to the Light/Lock card to switch the pillar lights as and when required. Place the jumper over the pins MAG or STRIKE when selecting a Magnetic Lock or Strike Lock instal-

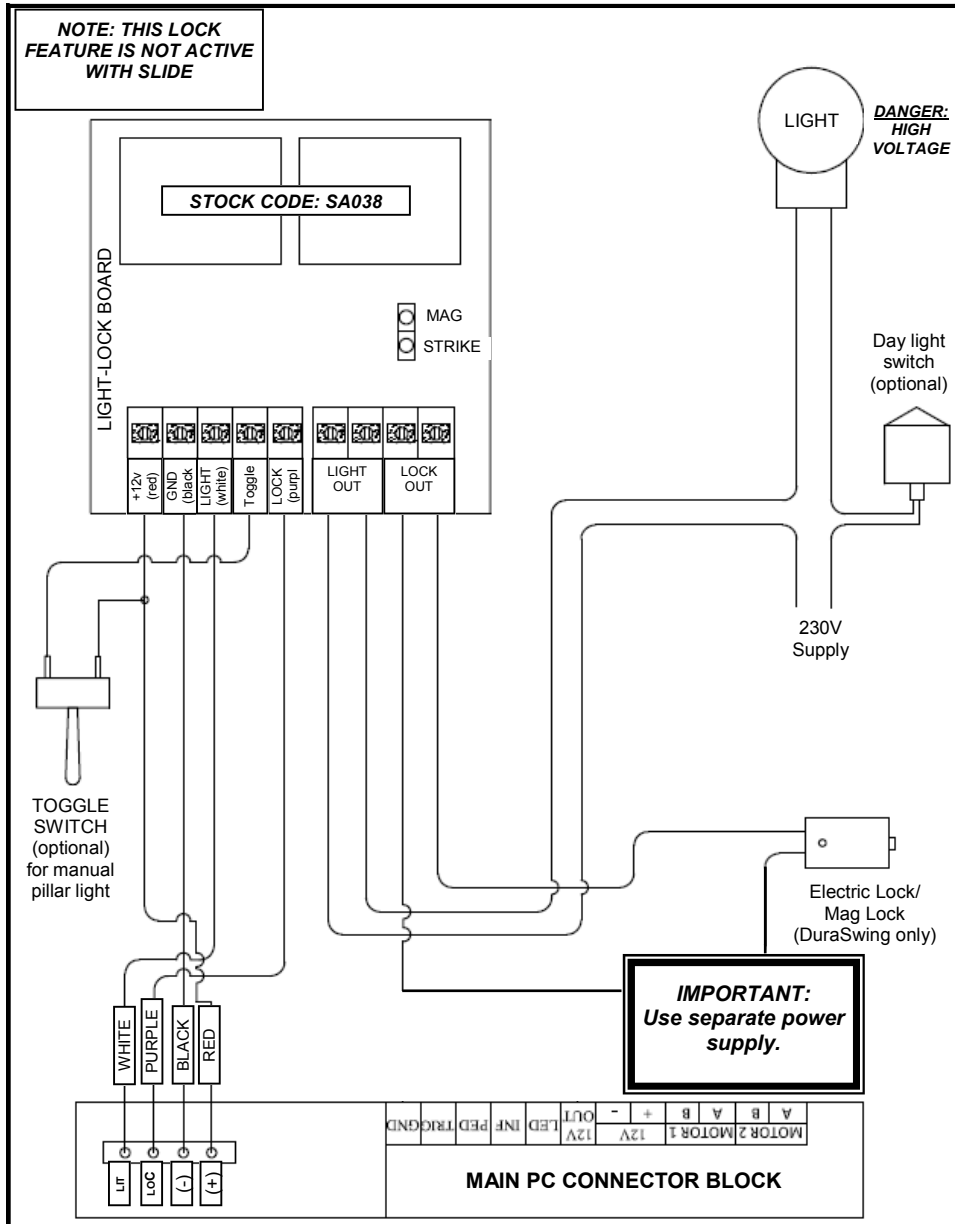

GENERAL SITE LAYOUT

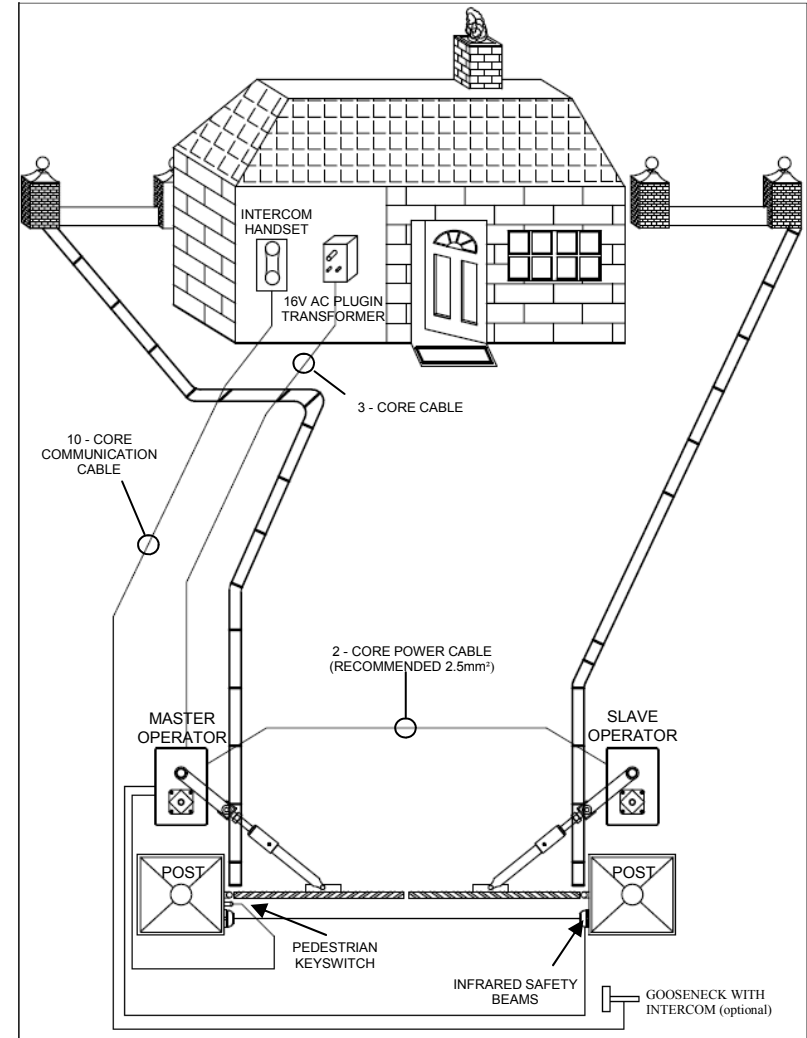

Typical inward swing, pedestal mount operation.

All cabling should be in conduit a minimum of 300 mm underground. Ensure that any high voltage (230V) cables are run in separate conduit. The transformer should be placed inside the house and then 16 VAC run to the charger module in the operator. The cable used to run the 16 VAC power should be 1.5 mm three core cable. **Do not use communication cable.** Alternatively a registered electrician can run 230V power to the gates and the transformer can be housed inside the gate operator.

GENERAL OPERATOR LAYOUT

Diagram showing the general layout for a pedestal mount type installation.

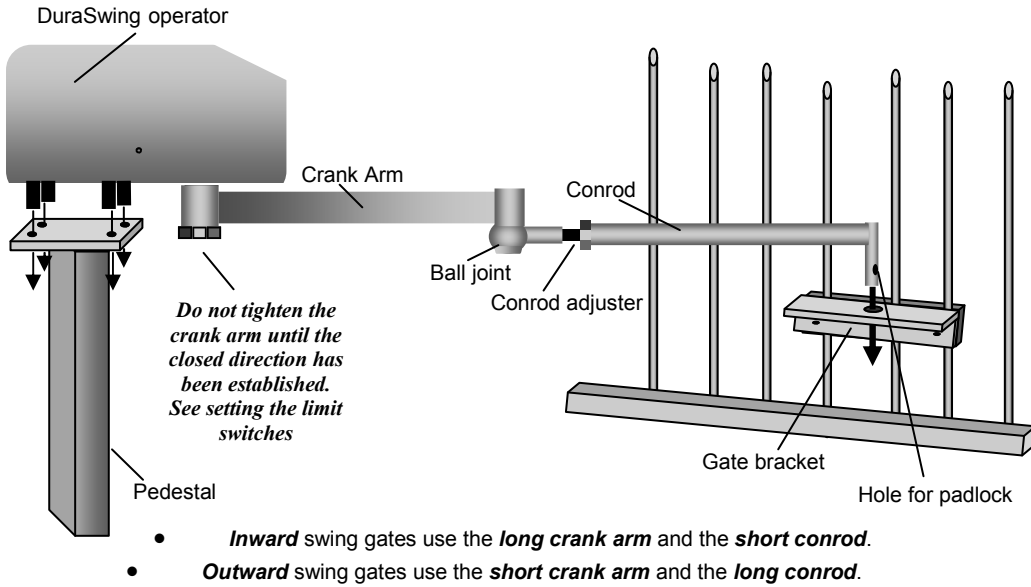
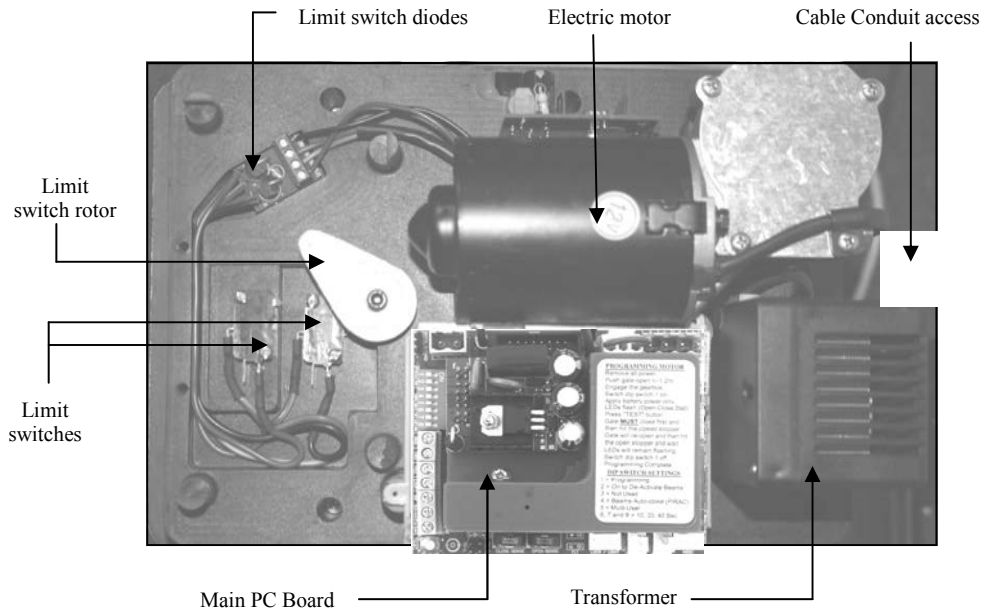
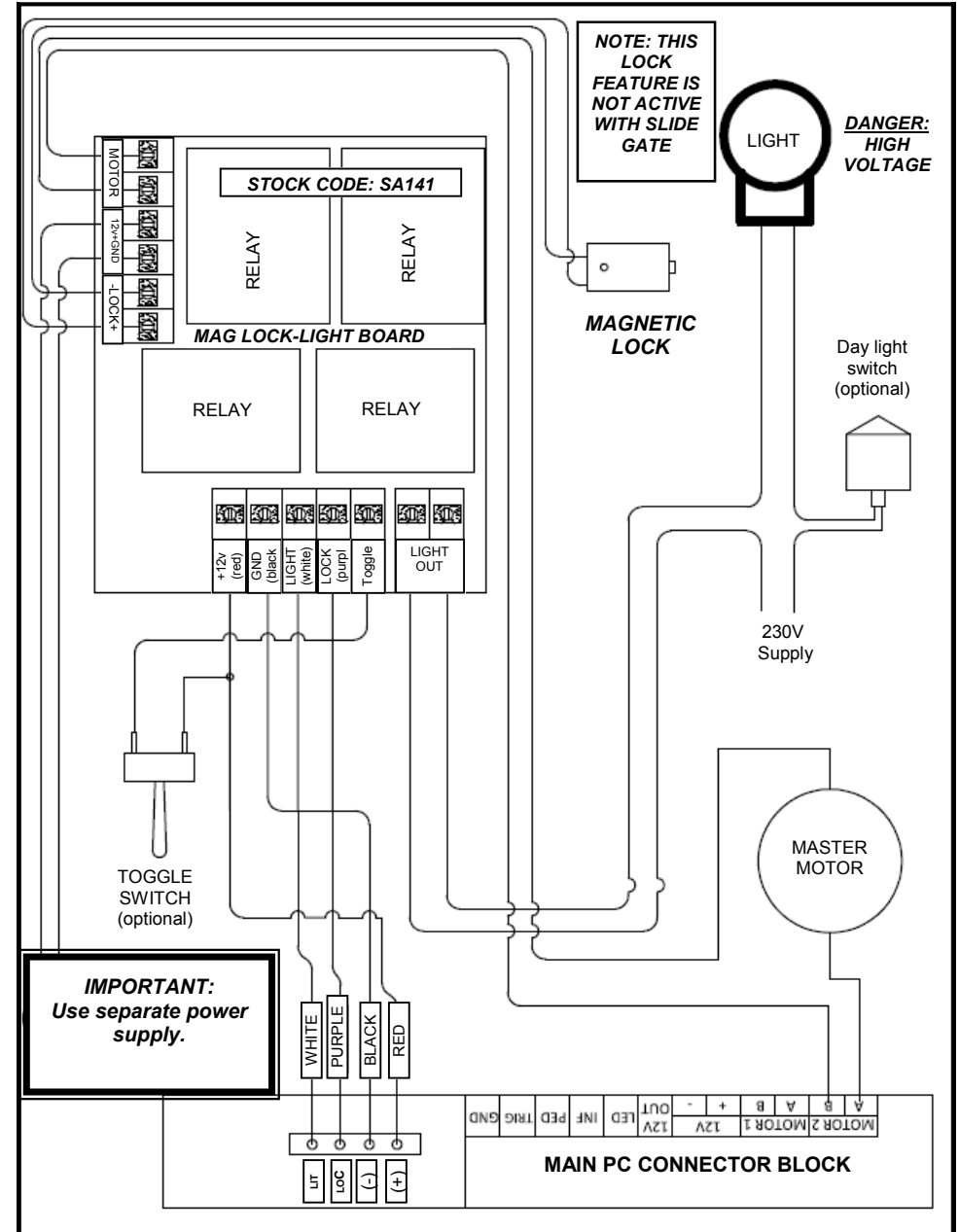

Diagram showing the top view of the operator with the lid and battery removed.



CONNECTING A MAG LOCK/LIGHT RELAY BOARD - (DOUBLE SWING ONLY SA041)

A magnetic lock can be set up on a double swing gate to provide extra security. Check the manufacturer's specifications before installing a magnetic lock. In order for the magnetic lock to operate on the DuraSwing gate motor, a D.A.C.E Mag Lock Card (SA141) must be connected to the main PC Board. The Mag Lock card will delay the opening of one leaf of the gate for 2 seconds. The power supply to the Mag Lock must not be taken from the motor battery or the PC Board as this will result in a flat battery or malfunction of the PC Board. The Mag Lock Card can also turn pillar lights on when a trigger is received. Pillar lights should only be connected by a registered electrician.



WIRING TWO SETS OF INFRARED SAFETY BEAMS (DuraOptics)

Used to stop the gate closing even if the vehicle is past the first set of beams but it may still be in the path of the closing gate. One set mounted on the gate posts and the other set mounted clear of the gate when the gate is in the open position.

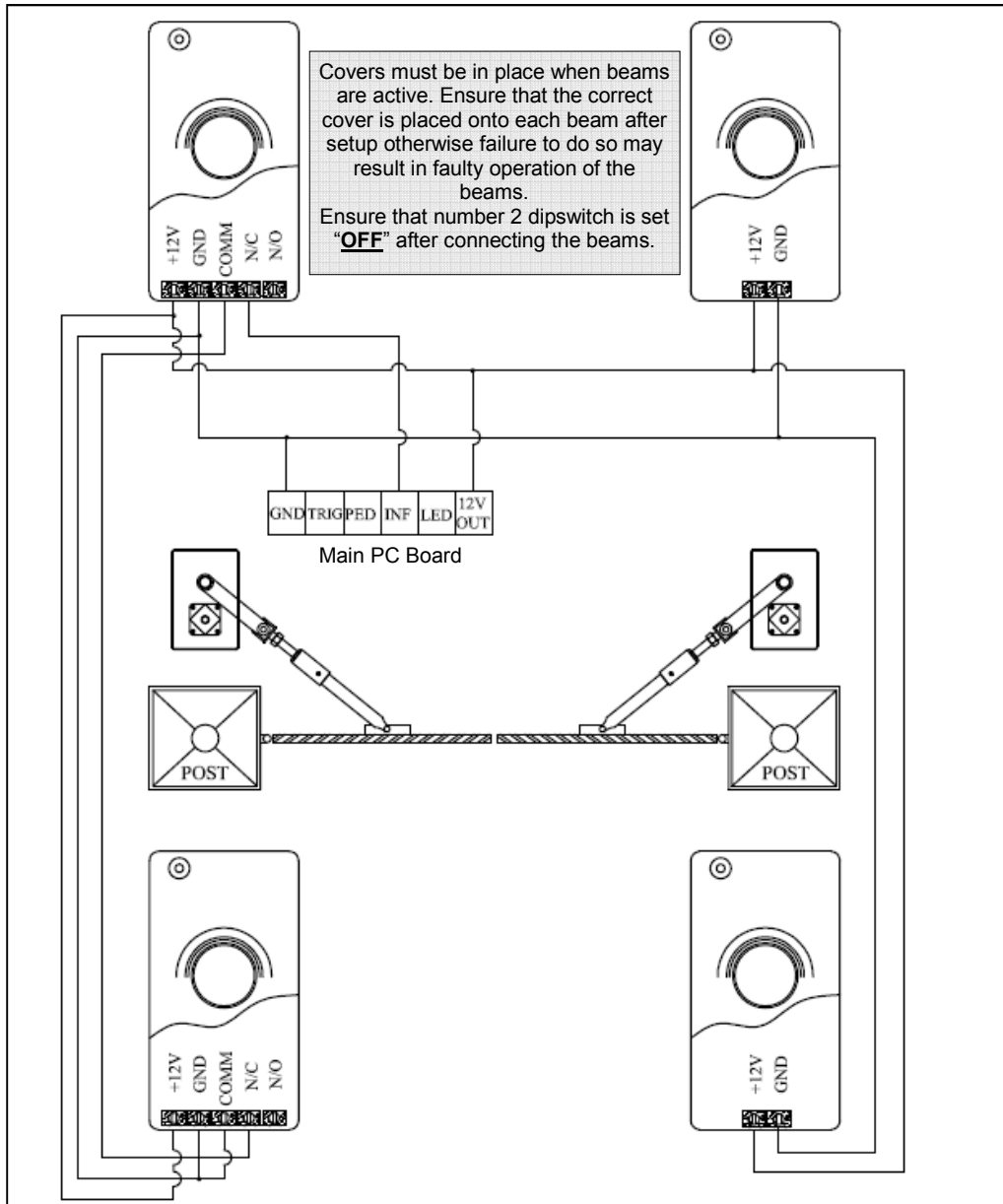

MAIN PC BOARD LAYOUT

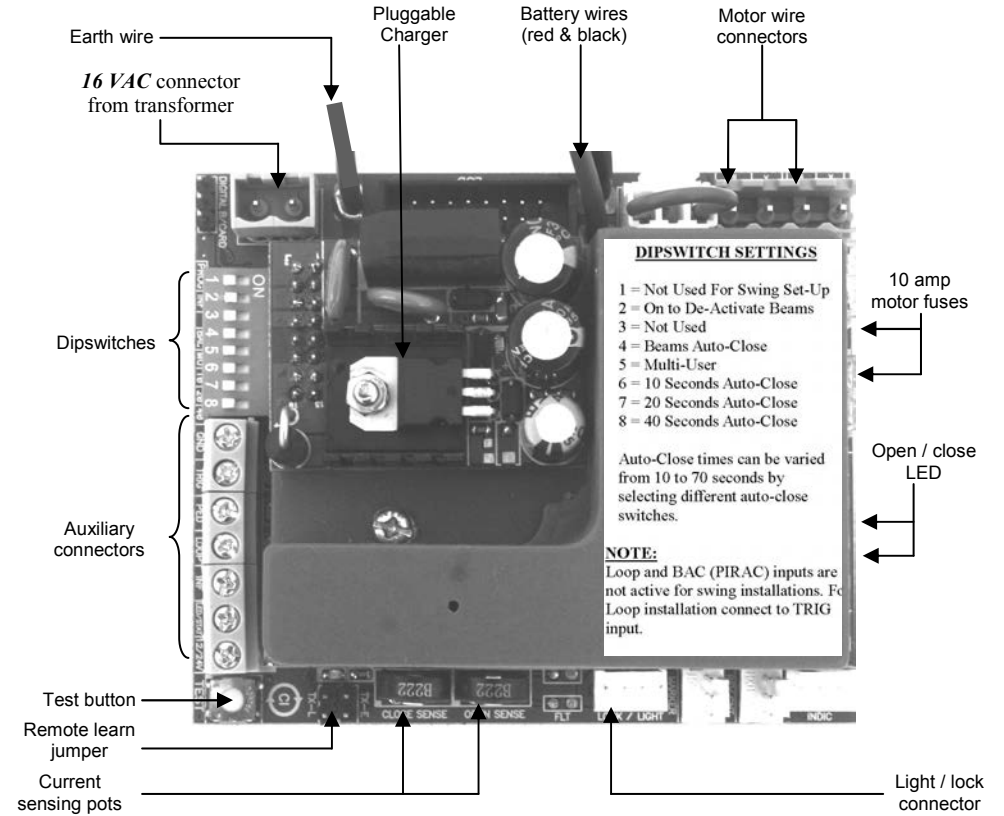

NOTE: The PC Board is a delicate piece of electronic equipment. Take care when connecting or disconnecting any wiring from the board. Ensure that **ALL** power is removed before any wiring connections are done on the board, failure to do so may damage the board. **Do not reverse the battery polarity** as this will cause serious damage to the PC board. Do not spray any type of insecticide or lubricant spray onto the board as this may cause damage. Never touch the board with any metal objects (screwdrivers etc). Do not attempt to repair the board in any way, take the board to a recognized D.A.C.E. dealer for any repairs needed.

ELECTRICAL WIRING

WARNING: electrical shock may occur during installation of this equipment, please use caution at all times.

If the intention is to run **230V (high voltage)** to the motor, it is strongly recommended that the local E.C.A. (Electrical Contractors Association) is contacted in the area before **any** wiring is done to obtain the local requirements regarding electrical wiring regulations. Running 230V must be done by a **registered electrician**, failure to do this may lead to legal action in the case of electrical shock. Furthermore it is **illegal** to run 230V and communication (intercom) cables in the same conduit. D.A.C.E. recommends that the transformer is removed from the motor and plugged into an outlet socket inside the house. This means that the power running to the operators is 16 VAC and does not require an electrician to install it. All wiring must be sealed in conduit and buried underground. **(DO NOT** connect to pool pump that uses a timer or to pillar lights with a day night sensor. This will result in a flat battery).

ELECTRICAL WIRING cont.

To connect the power supply, run a three core 1.5mm cable from the transformer to the main PC board in the master operator. The 16 VAC output on the transformer must be connected to the 16 V input on the main PC Board. The remaining wire must be connected from the E on the transformer to the earth wire on the main PC Board. (see diagram). Alternatively the green earth wire must be connected to an earth spike buried in the ground.

DO NOT USE COMMUNICATION CABLE FOR POWER!!

WIRING FROM TRANSFORMER TO CHARGER

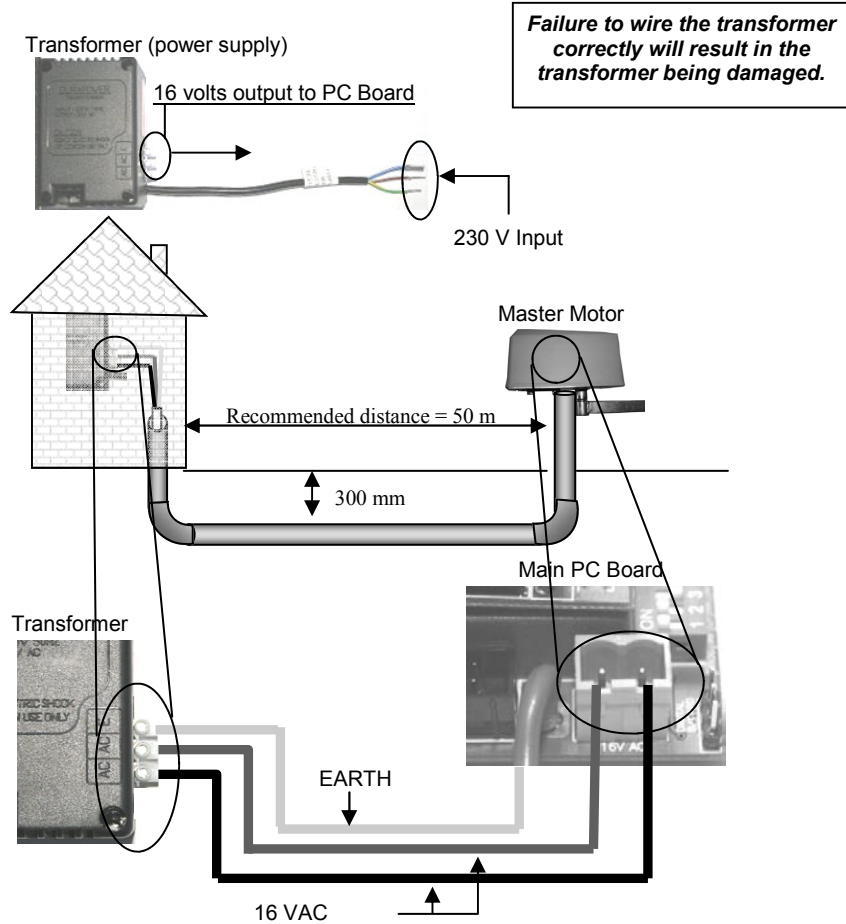

Place the cable in conduit a minimum of 300mm underground. The cable must be a minimum of 1.5mm three core cable. Ensure that the conduit is waterproof. Do not use communication type cable for the power supply. Do not join cables underground.

WIRING ONE SET OF INFRARED SAFETY BEAMS (DuraOptics)

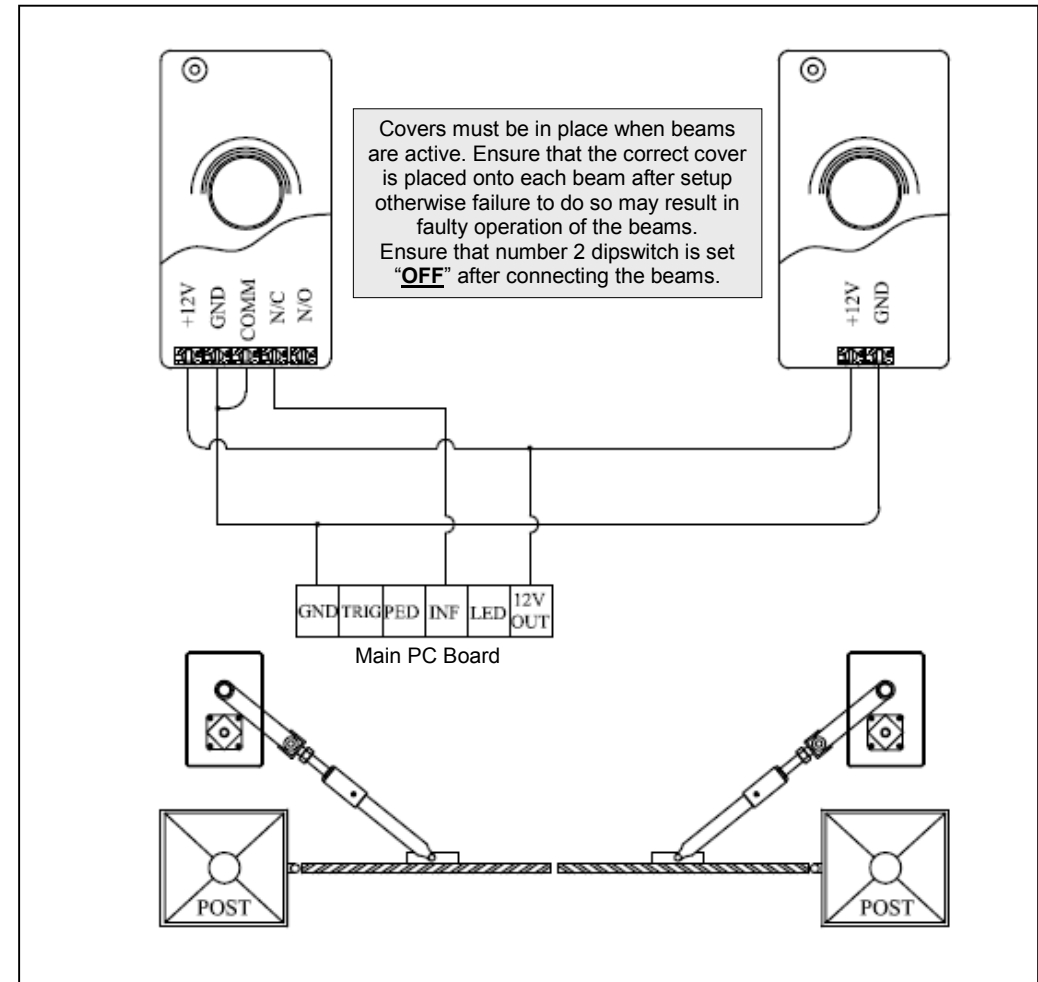

Note: although the installation of infrared safety beams does reduce the risk of the gate striking an object while closing it does not guarantee against it.

CONNECTING AN EXTERNAL RECEIVER

When connecting any auxiliary equipment to the PC Board ensure that all power is removed from the PC Board.

A DuraTronic external receiver can be connected to the PC Board. This will be necessary if there are more than 15 remotes to be used or if the range of the on-board receiver is not sufficient. The DuraTronic external receiver can hold 128 remotes. The DuraTronic receiver should be mounted outside the operator housing for increased range.

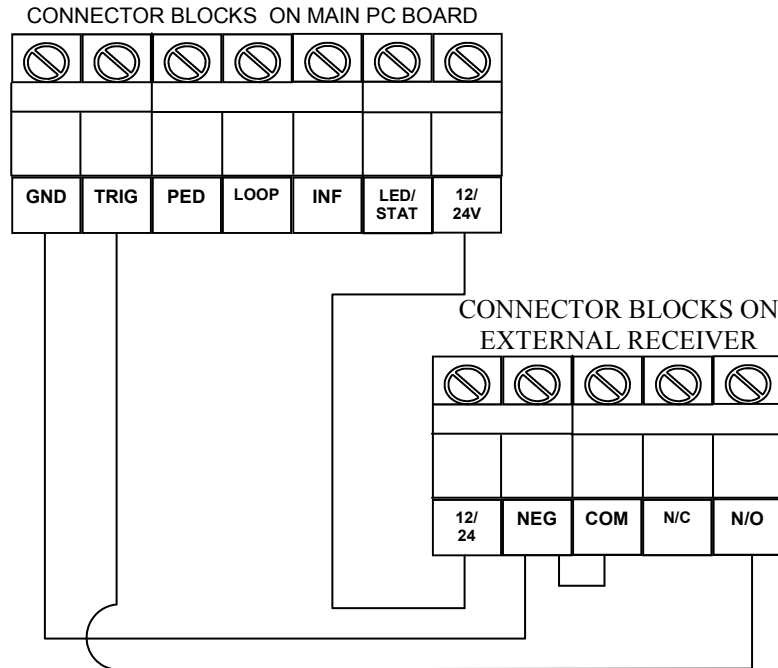

To program remotes to the receiver:

1. Press and hold the button on the remote.
2. Place the jumper over the two TX LEARN pins for 1 second.
3. Remove the jumper.
4. Release the button on the remote.

Repeat the above steps for each remote to be programmed.

PEDESTRIAN OPERATION: A separate receiver, keyswitch or keypad must be connected to operate the gate in the pedestrian mode. The connection is done in the same manner as the diagram above with the exception of the TRIG connection. Instead of TRIG to N/O it must be PED on the main PC Board to N/O.

In pedestrian mode the gate will open partially and then close automatically after 6 seconds.

MOUNTING THE OPERATORS

The operators can be mounted either as a **Wall Mount** and **Pedestal Mount**.

The diagrams below show the two types of mounting.

When a **Wall Mount** is used it is recommended that normal coach screws and plugs are used to secure the wall mount to the wall.

For a **Pedestal Mount** a 400mm square hole must be dug (per pedestal) and then filled with concrete and the pedestal placed in the centre. Do not mount the operators until the concrete is fully cured.

NOTE: the diagrams below show mounting position for Inward Swing. For Outward Swing the operators must be turned 90° on the mountings. (see pg 12 or 15).

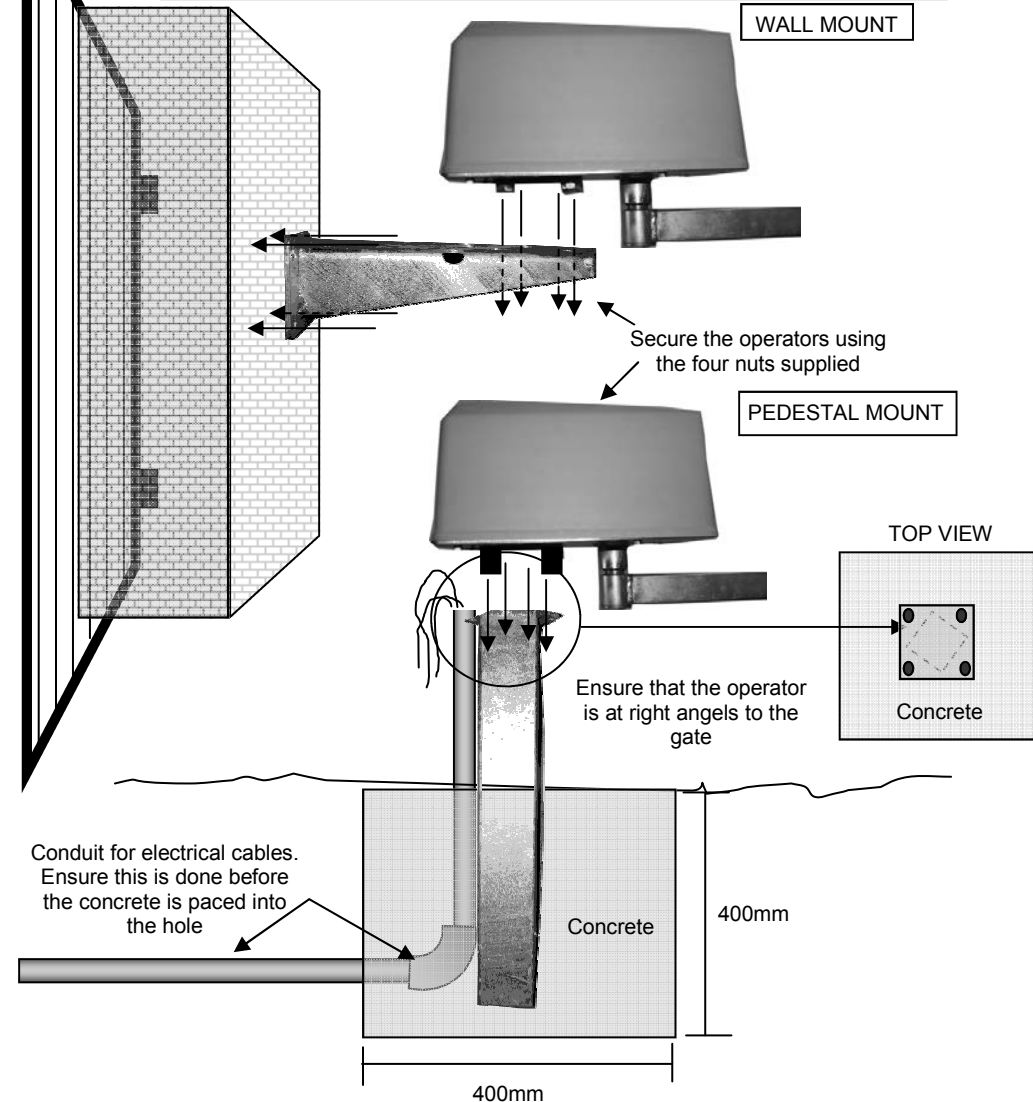

PEDESTAL MOUNT

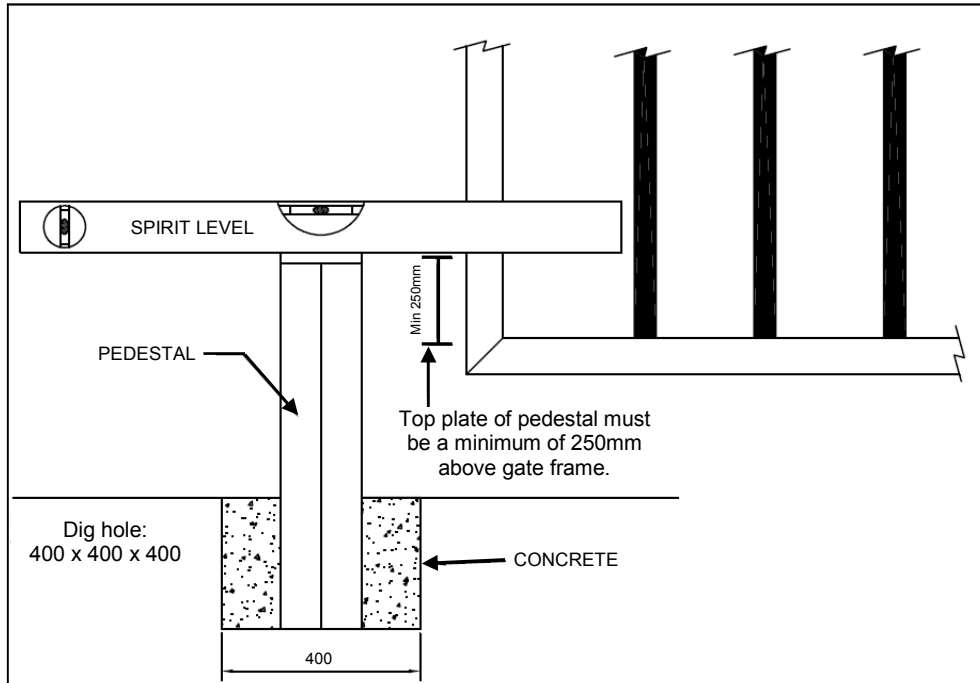

Some points to remember:

- Measurements given for the mounting positions are guidelines only and should be used as such.
- Each installation will vary slightly.
- To establish the correct position of the operators they should be held temporarily in position with the crank arms loose on the shaft, the gates can then be opened and closed by hand to ensure that they are in the correct position.
- For a **Pedestal Mount** the pedestal must be placed in the centre of a hole 400mm square and the hole then filled with concrete. The concrete must be set completely before the operators are mounted on the pedestals.
- When wall mounts are to be used, the wall mount should be mounted using coach screws and plugs.
- In certain cases such as outward swing on wall mounts, the wall mount may need to be altered in order to make the wall mount completely secure on the wall.. (see pg 15).

When outward swing gates are setup the operators will protrude into the driveway by 155mm on each side of the driveway. Any attempt to mount the operators in any other manner will cause operational problems with the gates.

OTHER FUNCTIONS

PARTY MODE: or Auto-close override. This function is normally used when higher than normal traffic volumes are expected and one does not wish to repeatedly open the gate. To operate the party mode set up, push and hold the gate's trigger button until the gate starts to open. Release the trigger. The gate will now stay open until it is reset into normal operating mode. To reset the gate into normal operating mode, push the gate's trigger button twice within three seconds. The gate will now operate as normal.

OVERCURRENT SENSING: the PC Board is designed to detect overcurrents. This means that if the gate hits an object or is obstructed it will see an increase in the current and the gates will stop driving. The results of the detected overcurrent will be different depending on what the gate is doing at the time of the overcurrent.

- If the gate is closing and an overcurrent is detected the gate will stop and then re-open.
- If the gate is opening and an overcurrent is detected, the gate will stop and will not move until it receives another trigger or the auto-close time is reached.
- If the gate senses an overcurrent 5 times in succession, the gate will stop working regardless of any trigger. To reset the gate the AC power must be disconnected for 5 seconds then reconnected. The gate will operate as normal as long as the obstruction has been removed.

Setting the overcurrent sensitivity:

The sensitivity can be adjusted dependent on gate's requirements. It must be noted that if the sensitivity is set too low, the gate will drive harder when an obstruction is encountered increasing the risk of injury or damage to a vehicle/object. Before adjusting the sensitivity check that the gate is operating correctly i.e. look for hinges that are rusted, branches or garden growth hindering operation etc.

There are two **POTs** found on the PC Board. One pot is to set the open sensitivity and the other is to set the close sensitivity.

To decrease sensitivity (usually because a heavier gate is being automated or due to wear and tear over time) use a small flathead screwdriver and turn the pot clockwise. The adjustment should be done in very small increments, until the desired sensitivity is achieved. Use **extreme caution** when setting the pots as this can cause severe injury or damage if the sensitivity is set too low.

To increase sensitivity (usually because a very light gate is being automated) turn the pot anti-clockwise. Take care not to set the pot too sensitive as this may cause the gate to overcurrent due to other external forces such as wind etc.



CLOSED POT OPEN POT

Flathead Screwdriver

LED FUNCTIONS

TRG: this LED will flash once when a trigger signal has been detected. If this LED is on solid it indicates a possible fault in one of the trigger wires i.e. intercom, receiver etc.

PED: this LED is the same as the trigger LED. It will indicate when a pedestrian trigger has been received.

LOOP: the connector is a dedicated input for slide operators and as such this LED is not active with swing operators.

INF: this LED will switch off when a vehicle or pedestrian crosses the beam. If this LED is off continuously it indicates a possible fault with the beams or the wires that connect the beams.

LED/STAT: this LED has a number of functions and it displays the following:

Flashing once every two seconds	= gate closed and AC power is connected.
Flashing once per second	= gate moving.
On solid (no flashing)	= gate open.
Off	= AC (mains) power disconnected.

12/24V: -this LED indicates that the 12 volt output is working. If this LED is off it indicates that the 3 amp resettable fuse has blown. In this case the power must be removed from the board and then re-connected to the board. This will reset the fuse and normal operation can continue.

CHARGE: this LED is on when the AC power (mains) is connected. If this light is not on the battery will continue to operate the gate but will eventually run flat and the gate will stop working. This LED must be on at all times.

OPEN: this LED is on when the gate is opening or is in the open position.

CLOSE: this LED is on when the gate is closing or is in the closed position.

REV: this LED flashes when the motor operates (*for slide gate operators only*).

LOW BATT: this LED indicates that the battery is low or flat. This is a red LED and will flash continuously until the battery is either recharged or changed.

LED LAYOUT

PLEASE NOTE:
LOOP input is used
for slide operators
ONLY!!

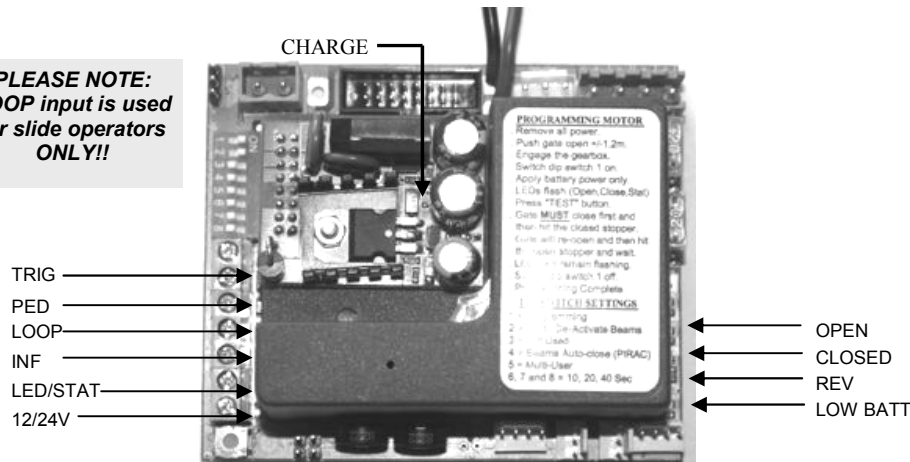

PEDESTAL MOUNT : INWARD SWING

All INWARD swing installations require LONG crank arms and SHORT conrods.

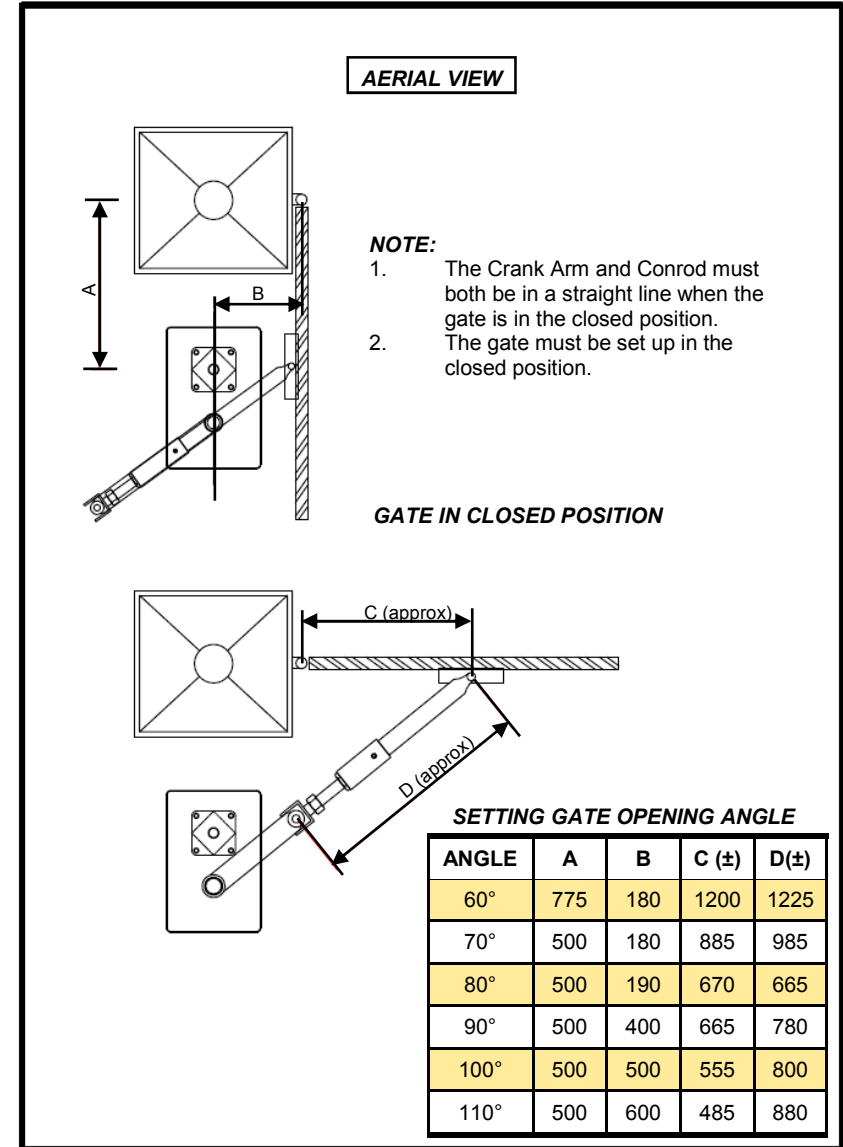

The above diagram shows the correct position for the pedestal when installing an Inward Swing pedestal mount motor.

Measurements **A**, **B** and **C** are all taken from the **hinge** of the gate.

When the gate is in the closed position the crank arm and conrod must extend away at the point of the ball joint and form a **straight line**. Likewise, when the gate is in the open position the crank arm must **rotate back** over the conrod and still form a **straight line**.

PEDESTAL MOUNT : OUTWARD SWING

All OUTWARD swing installations require SHORT crank arms and LONG conrods.

AERIAL VIEW

NOTE:

1. Accurate positioning of the pedestal is critical.
2. Gate can only open a maximum of 90°
3. Order short Crank Arms when installing outward swing operators.
4. Recommended that measurement A should not be less than 475mm.
5. The Crank Arm and Conrod must be in a straight line when in the open position.
6. The gate must be set in the OPEN position.

SETTING GATE OPENING ANGLE

ANGLE	A	B	C	D
90°	475	70	772	1000
90°	500	70	550	890
90°	800	70	500	1110

NB: All measurements are given as guidelines. Each installation will vary marginally.

CRANK ARM
This system uses the short (205mm) Crank Arm.

When outward swing gates are setup the operators will protrude into the driveway by 155mm on each side of the driveway. Any attempt to mount the operators in any other manner will cause operational problems with the gates.

DIPSWITCH SETTINGS

AUTO-CLOSE

Auto-close is an option that allows the gate to close automatically after a chosen time delay, this delay can be from 10 to 70 seconds. Auto-close is selected by using the dipswitches on the main PC Board. Dipswitch numbers 6,7 and 8 are the auto-close time select switches. The times are as follows.

- 6 off ; 7 off; 8 off = no auto-close
- 6 on; 7 off; 8 off = 10 seconds
- 6 off; 7 on; 8 off = 20 seconds
- 6 off; 7 off; 8 on = 40 seconds
- 6 on; 7 on; 8 on = 70 seconds

Any combination can be used to select the desired auto-close time.

It is strongly recommended that DuraOptics safety beams are used when Auto-Close is selected as this reduces the chance of the gate closing on an object and causing injury or damage.

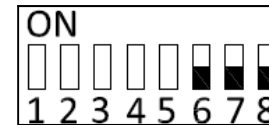

No's 6; 7 & 8: SETTING AUTO-CLOSE

INFRARED SAFETY BEAMS

Number 2 dipswitch is used to activate the safety beams. If no safety beams are used, number 2 dipswitch must be in the ON position. If safety beams are connected, number 2 dipswitch must be set to the OFF position. NOTE if number 2 dipswitch is OFF and there are no beams connected, the gate will not close.

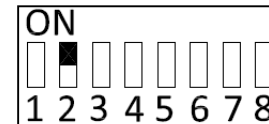

No.2: ON IF NO BEAMS

MULTI-USER MODE

To set multi-user mode, place number 5 dipswitch in the ON position.

NOTE !!! If Multi-user is selected, an auto-close time must also be selected. If an auto-close time is not selected, the gate will immediately close after opening.



No.5: ON FOR MULTI-USER

BEAMS AUTO-CLOSE

B.A.C. is not active with swing operators.



No. 4: MUST REMAIN OFF FOR SWING OPERATORS

PC BOARD CONNECTIONS

The following connectors are found on the main PC Board:

GND: This connector is used as a common ground for all auxiliary equipment. (**NOTE: THIS IS NOT EARTH**)

TRIG: This connector is the TRIGGER input, this will open /close the gate. This is normally used for the receiver and /or intercom trigger (not for pedestrian mode)

PED: This connector is to accommodate a pedestrian trigger (optional). The opening distance is pre-set and can not be changed. When the pedestrian trigger is used the gate will open partially and will close automatically after 6 seconds.

LOOP: This is a dedicated input for slide operators and is NOT active with swing operators. Please see page 29 for instructions for connecting a Loop Detector for a swing motor.

INF: This connector is used to connect infrared beams (optional). If the gate is closing and the beam is interrupted the gate will stop and reopen. If the gate is opening and the beam is interrupted it will have no effect on the gate. (see wiring diagrams for more details on wiring infrared beams)

LED/STAT: This connector can be used to connect a remote Light Emitting Diode (LED), an optional facility. The anode (+) must be connected to the LED connector and the cathode (-) must be connected to the GND connector. The remote LED will give the same indication as the STATUS LED on the PC Board.

12/24V: This connector is used to supply power to auxiliary equipment used i.e intercom; receiver; infrared beams etc. This output has a resettable fuse for protection. (see wiring diagrams for more details on wiring auxiliary equipment). **This is not to be used to power up a Magnetic Lock or Strike Lock.**

Ensure that all power is disconnected from the P.C.BOARD before any connections are made. Failing to do this will result in electrical shorts and major damage may occur to the PC BOARD.

CONNECTOR BLOCK ON MAIN PC BOARD

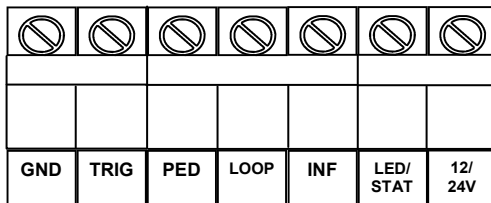

PLEASE NOTE: LOOP input is used for slide operators ONLY!!

PEDESTAL MOUNT : PANHANDLE INWARD SWING

All INWARD swing installations require LONG crank arms and SHORT conrods.

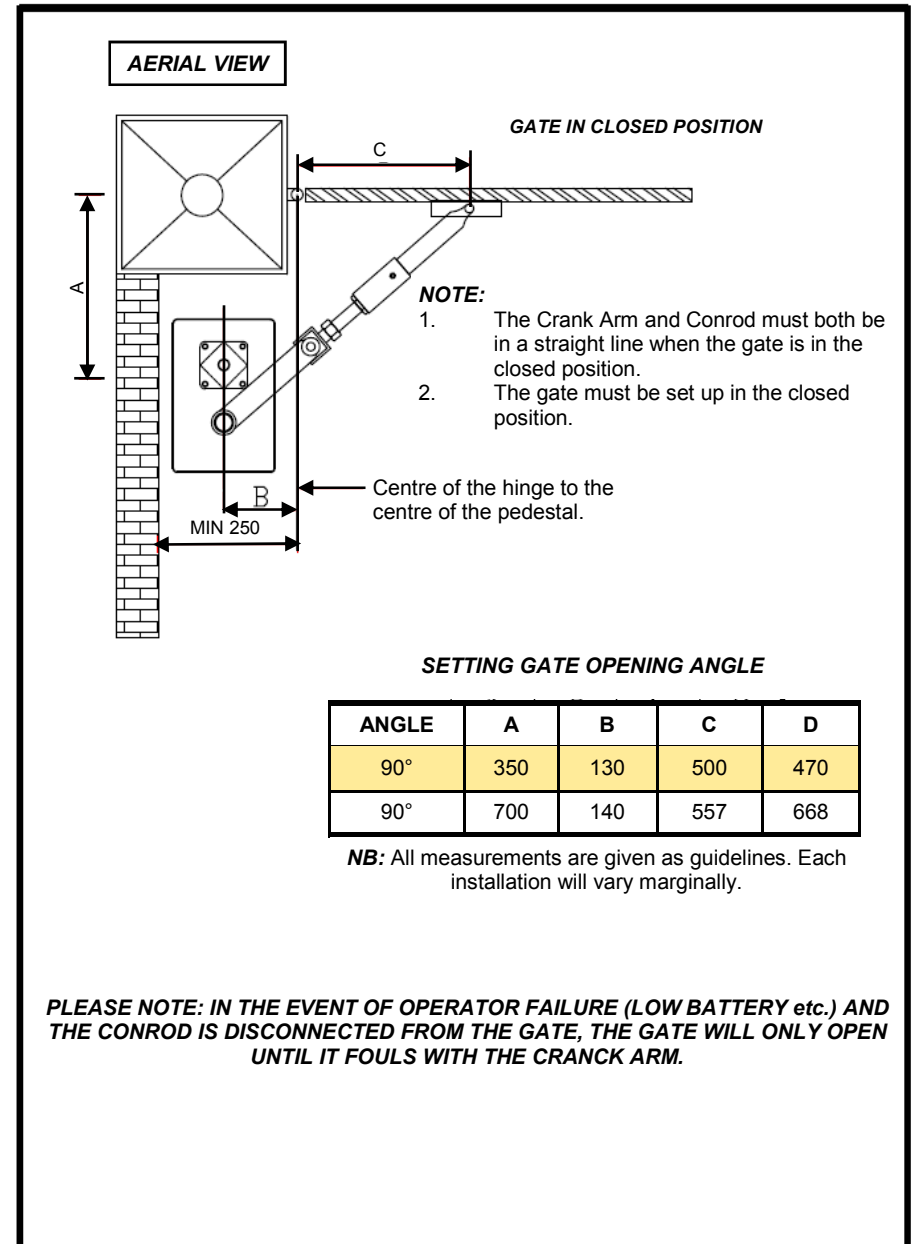

WALL MOUNT : INWARD SWING

All INWARD swing installations require LONG crank arms and SHORT conrods.

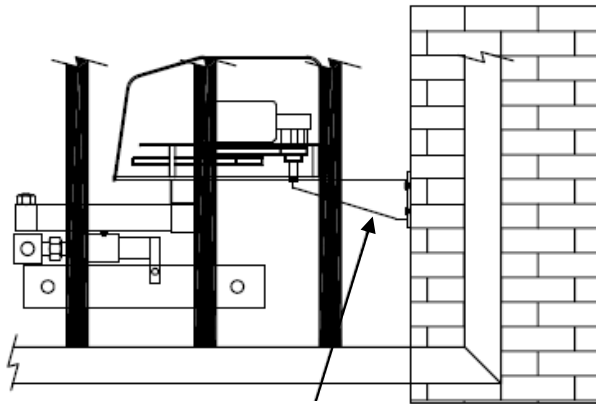

Use 12mm Coach Screws to secure the Wall Mount Bracket. Use a minimum of 4 screws per Wall Mount

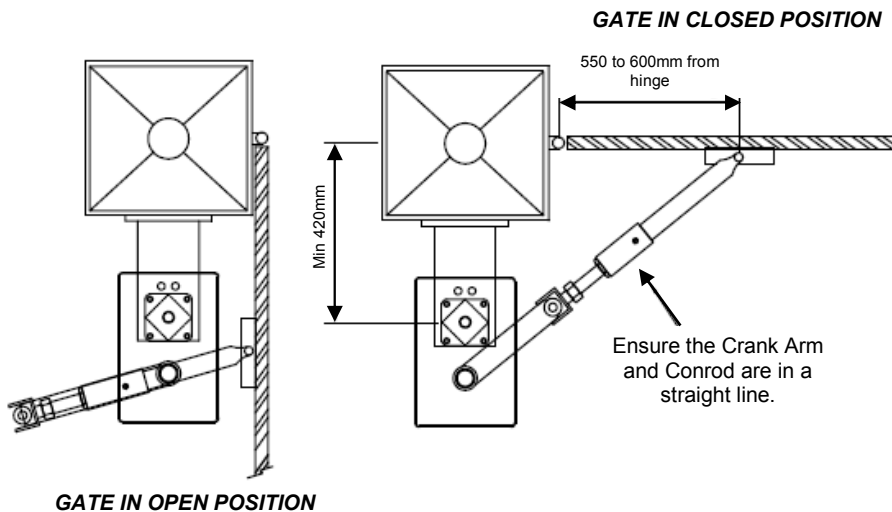

PROGRAMMING THE REMOTES

To program remotes to the on-board receiver complete the following steps. It is recommended that the remotes are numbered in order of programming. This will assist with erasing any lost or stolen remote at a later stage.

Step 1: press and hold the button that is to trigger this application on the remote. It is important that this button is continuously held from step 1 through to 3.

Step 2: place the jumper over the two pins on the PC Board called **TX- L** for 2 seconds.

Step 3: remove the jumper from the two pins.

Step 4: release the button on the remote.

That particular button on the remote is now programmed to the receiver.

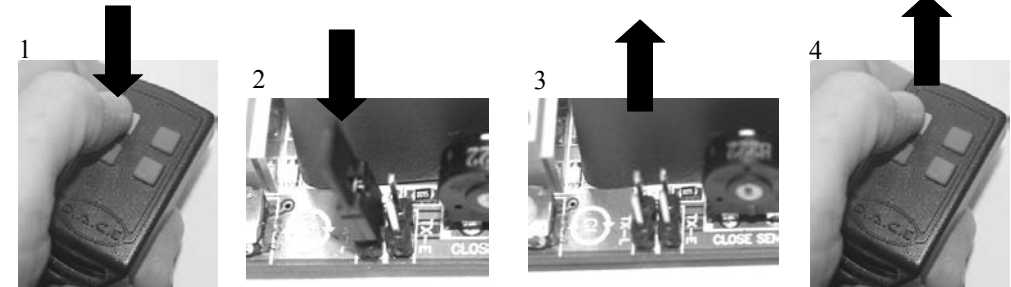

ERASING ALL REMOTES PROGRAMMED TO THE RECEIVER

Step1: place the jumper over the two pins called **TX-E** and count 4 flashes on the yellow LED on the receiver.

Step2: remove the jumper.

Step 3: replace the jumper and count 2 flashes on the LED.

Step 4: remove the jumper.

Step 5: replace the jumper and count 4 flashes on the LED

The LED will now flash rapidly for one second to indicate that all remotes have successfully been erased.

NOTE: The time between the jumper being removed and replaced on the pins must NOT exceed 2 seconds.

ERASING A SINGLE REMOTE PROGRAMMED TO THE RECEIVER

If the remotes are not numbered all remotes will need to be erased and reprogrammed once again. If all remotes are numbered it is possible to erase a single remote. The preceding remote is needed to erase the required remote. For example remote number 6 will erase remote number 7 etc.

Step 1: place the jumper over the **TX-E** pins.

Step 2: press the button of the preceding remote.

Step 3: remove the jumper.

The remote will now be erased. The next remote to be programmed will take the place of the erased remote. In this example it will take the place of number 7 and must be numbered as such.

4

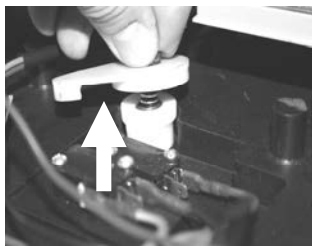
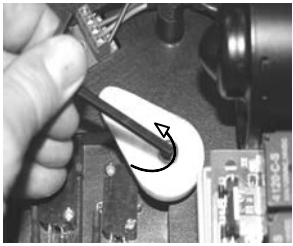

Loosen the limit rotor . The rotor is a black plastic cam shaped rotor. The rotor can be removed completely to assist with the set-up

5

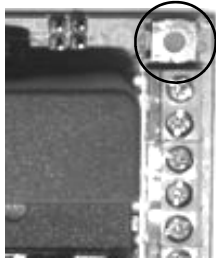

Press the test button on the PC Board. The gates will now start **opening**.

6

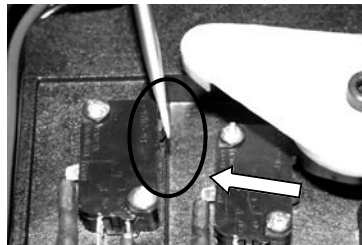

When gate reaches the required open position, press the limit switch. This is made easier using a small flat screwdriver. The motor will stop. The limit switch can be released when the operators have stopped running.

7

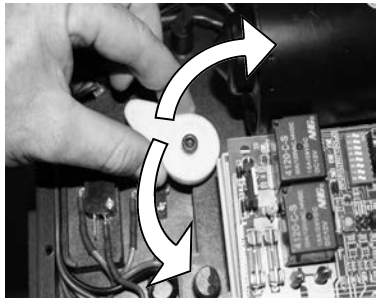

Lift and turn the rotor until it presses on the limit switch.

8

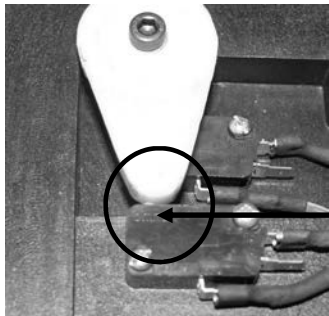

Tighten the rotor . **Do not over tighten**. The limit switches are now set and the gates can now be operated.

Rotor on open limit switch.
Rotor must be in this position when the gates are fully open.

WALL MOUNT : OUTWARD SWING

All OUTWARD swing installations require SHORT crank arms and LONG conrods.

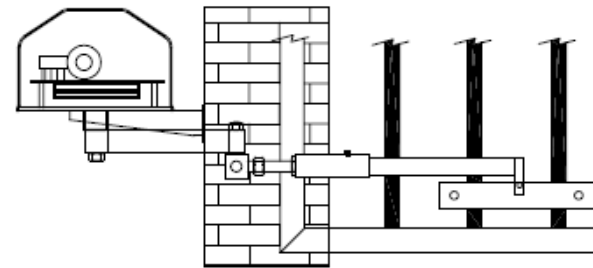

GATE IN OPEN POSITION

This measurement is critical!

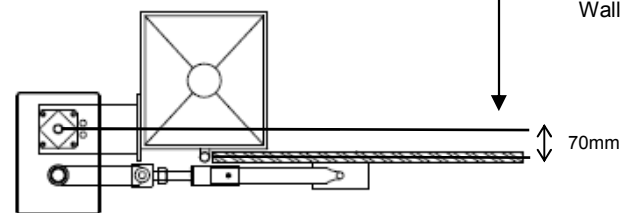

With the gate in the open position, the distance between the centre line of the Wall Mount Bracket and the inner face of the gate must be 70mm.

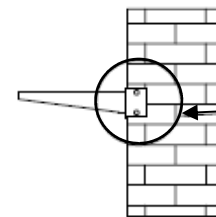

With the outward swing Wall Mount method, the Wall Mount Bracket must be modified and a steel plate (not supplied) must be bolted or welded to the bracket so that it can be fastened on the inside of the gate post.

When outward swing gates are setup the operators will protrude into the driveway by 155mm on each side of the driveway. Any attempt to mount the operators in any other manner will cause operational problems with the gates.

WIRING THE SLAVE OPERATOR

Conduit must be run between the two operators with a **2.5mm cable** from the master motor to the slave motor. This cable is connected from the main PC Board on the master to the slave motor limit switch diodes. Using thinner cable will result in a voltage drop across the driveway resulting in the gates operating at different speeds (i.e the slave will move slower than the master).

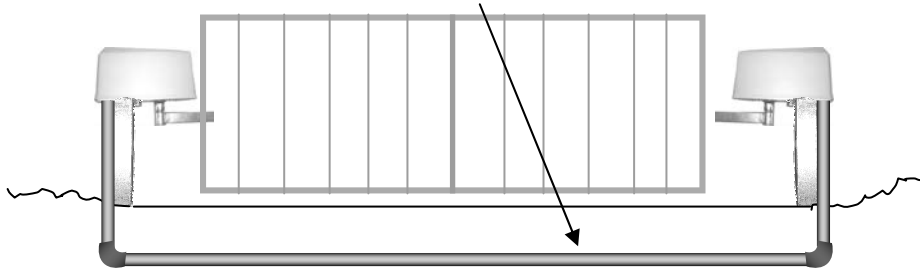

Ensure that the cable is connected in the correct order. The cable must be connected from the PC Board output labeled **MOTOR 2**, to the limit switch diodes on the slave operator. The cable that is connected to the "A" output must be connected to the "A" input on the limit switch diodes. And the "B" output must be connected to the "B" input. See diagram below.

Main PC Board on the operator

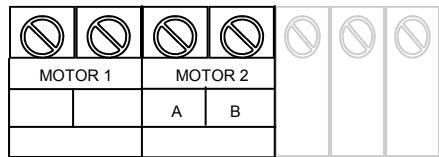

Limit switch diodes on the slave operator

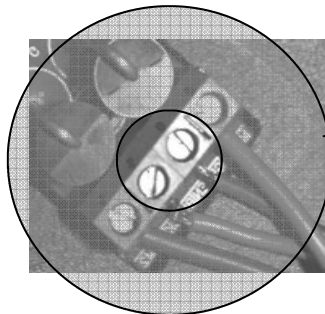
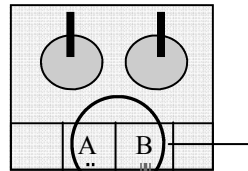

SETTING THE LIMITS

There are two limit switches and a limit rotor in each operator. The function of these is to stop the operators turning when the limit switch is struck by the rotor which is attached to the main shaft. Before setting up the limit switches you have to establish the closing direction of the operators. The operators should automatically drive to the closed position when first powered up but as each site is unique it may not. Apply power to the motor and take note of the direction that the shaft turns.

NOTE: If it is determined that the operators are turning the correct way, continue to set up the limit switches as shown below.

If the operators are turning the incorrect way you must reverse the motor wires. Follow the instruction below before continuing to set up the limit switches.

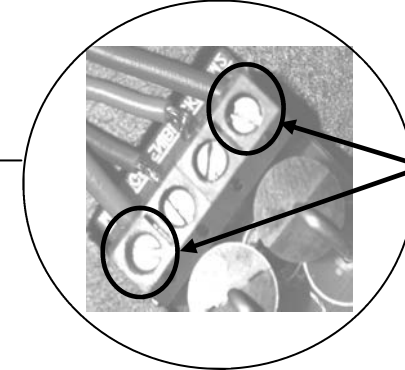
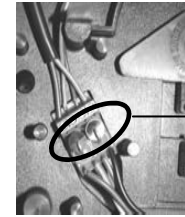

In order to reverse the motor direction, reverse these two wires.

Remove the power. Reverse the motor wires at the limit diodes as shown above. The operators should be running in the correct direction i.e. when the CLOSE LED is on the gates must be closed and when the OPEN LED is on the gates must be open. Now proceed to set up the limit switches.

1



Stand the battery up in a vertical position to allow for access to the limit rotor.

2

DO NOT REVERSE BATTERY CABLES

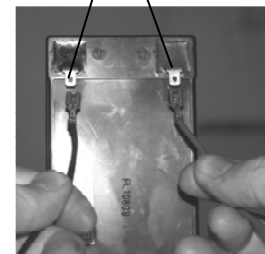

Apply the battery power. The operators will automatically turn until the **closed** limit is struck.

3



Before tightening the crank arms ensure that the gates are set up correctly using the diagrams on pages 11 –15. The gates must now be placed in the closed position and the crank arms can now be tightened. (23mm spanner.)