

SmartSolar™ Kit Gen 2

Solar Power Kits For Automatic Technology Openers

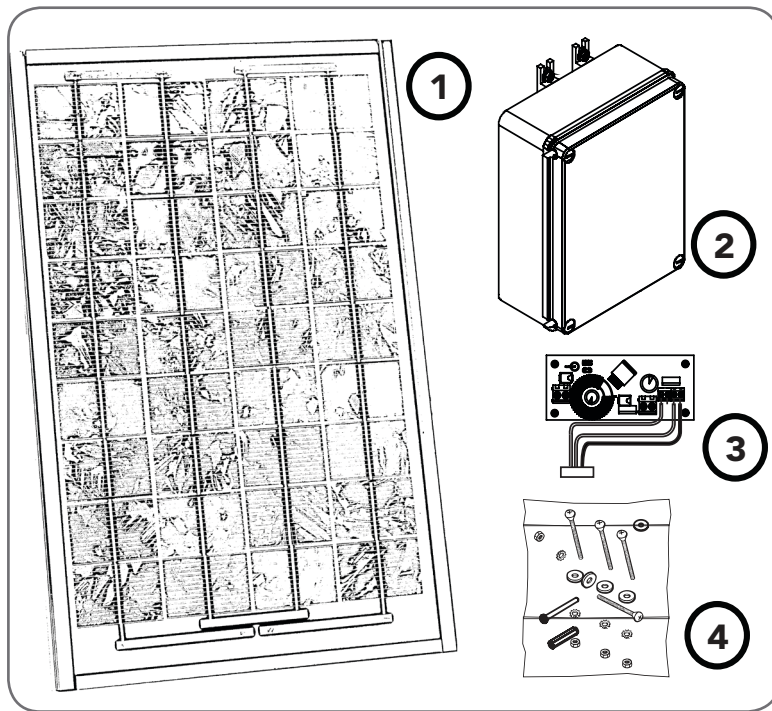

| SMARTSOLAR™ KIT GEN2 | | |
|----------------------|------------------------------------|-----|
| ITEM | DESCRIPTION | QTY |
| 1 | SOLAR PANEL - 30 WATT STP030-12/Lb | 1 |
| 2 | BATTERY PACK (2 X 12 Ah) | 1 |
| 3 | CHARGER BOARD (WITH HARNESS) | 1 |
| 4 | ACCESSORY PACK | 1 |

| ACCESSORY PACK | | |
|------------------------------------|---------------------------------|-----|
| ITEM | DESCRIPTION | QTY |
| 5 | 2 PIN SOLAR SHUNT | 1 |
| GEWISS MOUNTING KIT (64805) | | |
| 6 | MOUNTING LUGS FOR GEWISS BOX | 4 |
| 7 | SCREW "P" M3.5 X 13 | 4 |
| SOLAR BATTERY CABLE KIT (61821) | | |
| 8 | CABLE 2 CORE R&B X 1.0MM (2.5M) | 1 |
| 9 | NYLON GLAND M16-07B | 1 |
| SOLAR PACK 01 (61783) | | |
| 10 | PAN HEAD SCREW M4 X 8 | 4 |
| SOLAR PACK 02 (61784) | | |
| 11 | TAPTITE SCREW "P" M4 X 8 | 4 |
| SOLAR PACK 03 (61492) (GDO-8 ONLY) | | |
| 12 | BRUSH CARD 2047 L/F HARNESS | 1 |
| 13 | NYLON CABLE GLAND PGB7-07B | 2 |
| 14 | PAN HEAD SCREW M6 X 12 | 1 |
| 15 | WASHER 6.4X20.6X1.2 GAL | 1 |
| 16 | WASHER RUBBER 1/16"X1"X3/8" | 1 |
| 17 | TIE MOUNT CM-13 (ADHEISIVE) | 4 |
| 18 | CABLE TIE 4" GT-100M | 4 |
| SOLAR PACK 04 (61786) | | |
| 19 | TAPTITE SCREW "P" M3 X 8 | 4 |
| SOLAR PACK 05 (61787) (GDO-9 ONLY) | | |
| 20 | THRUSS SER HD SCREW "S" M4 X 8 | 2 |
| 21 | TAPTITE SCREW "P" M4 X 8 | 3 |
| 22 | PCB SUPPORT 76X27 | 1 |

Installing the Solar Panel

| TOWN | Latitude (L°) | Panel Angle (α°) |
|---|---------------|------------------|
| HOBART | 42.5° S | 57.5° |
| MELBOURNE | 37.5° S | 52.5° |
| CANBERRA, ADELAIDE, AILBANY | 35° S | 50° |
| SYDNEY | 33.5° S | 48.5° |
| NEWCASTLE, BROKEN HILL, PORT AUGUSTA, PERTH | 32.5° S | 47.5° |
| BRISBANE, OODNADATTA, GERALDTON | 27.5° S | 42.5° |
| TOWNSVILLE, TENNANT CREEK, PORT HEDLAND | 20° S | 35° |
| DARWIN | 5° | 20° |

Unpack the Kit

Unpack the Battery Box and the Solar Panel and inspect them for any damage in transit.

Mount the Solar Panel

- Determine a mounting point for the solar panel as close as possible to the intended opener. The length of cable from solar panel to solar charger must not exceed 5m.
- The solar panel should be faced to the North for maximum effect. Solar panel output is directly proportional to the amount of sunlight to which it is exposed. Thus, the panel should be positioned to the north due to Australia's southern location.
- The angle to tilt the solar panel for maximum exposure to the sun is determined by the following equation: $\alpha^\circ = L^\circ + 15^\circ$

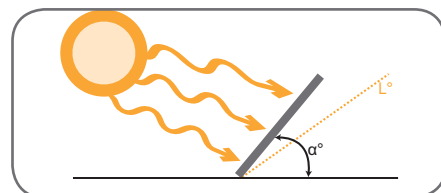

Where "α°" is panel's tilt angle from the horizontal, and "L°" is the latitude of the mounting location. Refer to table, for a list of pre-calculated panel angles for major centres in Australia.

Swing Gate Opener Set Up

DCB-05V2

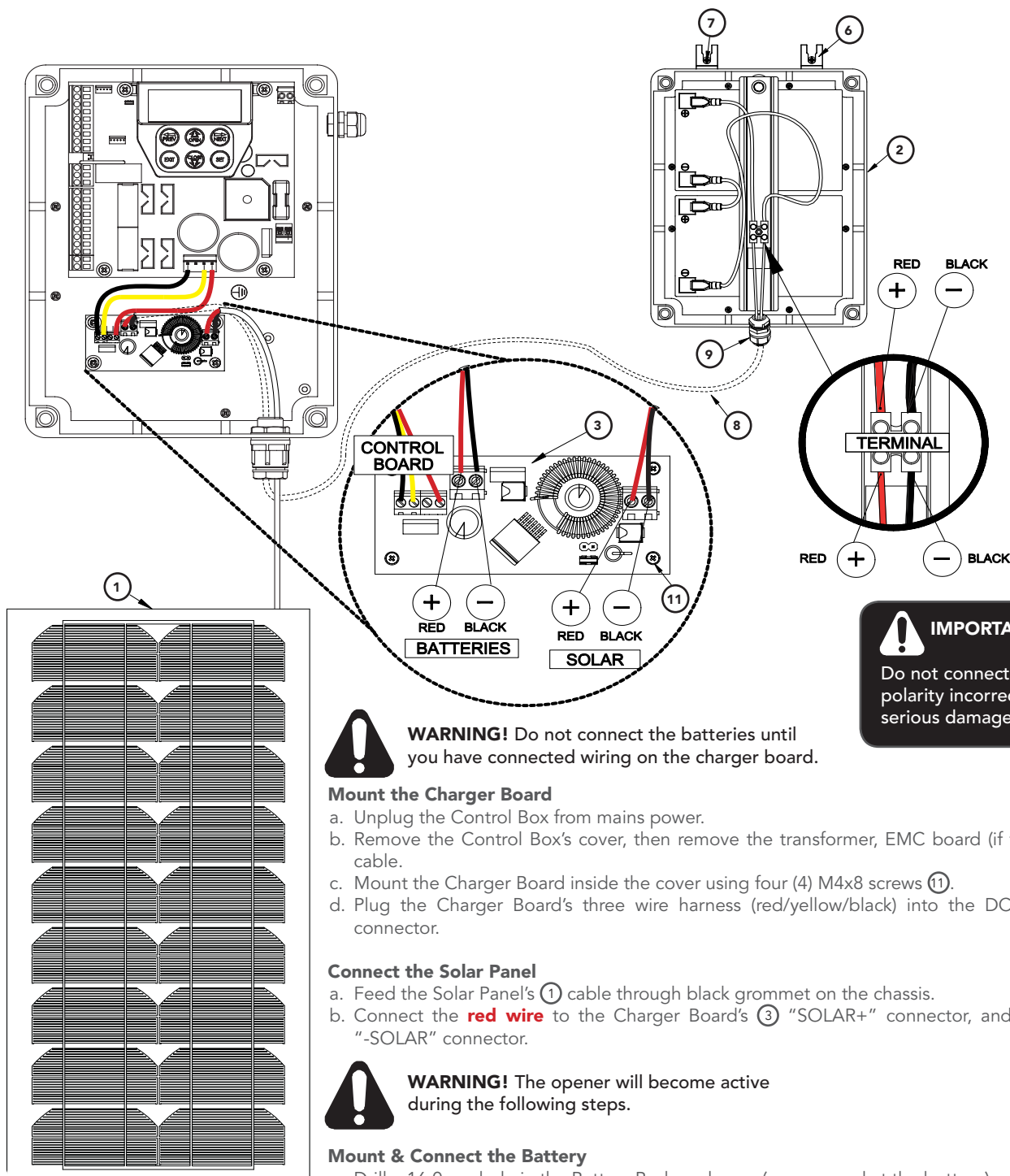

WARNING! Do not connect the batteries until you have connected wiring on the charger board.

Mount the Charger Board

- Unplug the Control Box from mains power.
- Remove the Control Box's cover, then remove the transformer, EMC board (if fitted) and mains power cable.
- Mount the Charger Board inside the cover using four (4) M4x8 screws (11).
- Plug the Charger Board's three wire harness (red/yellow/black) into the DCB-05 board's "SBC-02" connector.

Connect the Solar Panel

- Feed the Solar Panel's (1) cable through black grommet on the chassis.
- Connect the **red wire** to the Charger Board's (3) "SOLAR+" connector, and the **black wire** to the "-SOLAR" connector.



WARNING! The opener will become active during the following steps.

Mount & Connect the Battery

- Drill a 16.0mm hole in the Battery Pack enclosure (recommend at the bottom) and fit nylon gland (9).
- Mount the Battery Pack (2) using the mounting lugs (6) and screws (7) close to the control box.
- Feed the 2-core 18awg gauge cable (8) through the Battery Box's nylon gland (9).
- Connect the **red wire** to the Battery Box's "+" terminal, and the **black wire** to the "-" terminal
- Feed the other end of the 2-core 18awg gauge cable (8) through the drive unit's black grommet.
- Connect the **red wire** to the Charger Board's (3) "BAT+" connector, and the **black wire** to the "-BAT" connector.

Setup and Test the Opener

- Select Menu 7 on the DCB-05 control board, press "SET", select Sub Menu 7 ("Battery/Solar") and enable using the "OPEN" and CLOSE" buttons.
- Setup travel limits and transmitters as per the DCB-05V2 instruction manual.
- Press either "OPEN" or "CLOSE" buttons, or use a transmitter to operate the gate.
- Refit the Control Box's cover.



IMPORTANT WARNING!

Do not connect battery or solar panel polarity incorrectly - this will result in serious damage to components.

Sliding Gate Opener Set Up

NeoSlider™V2

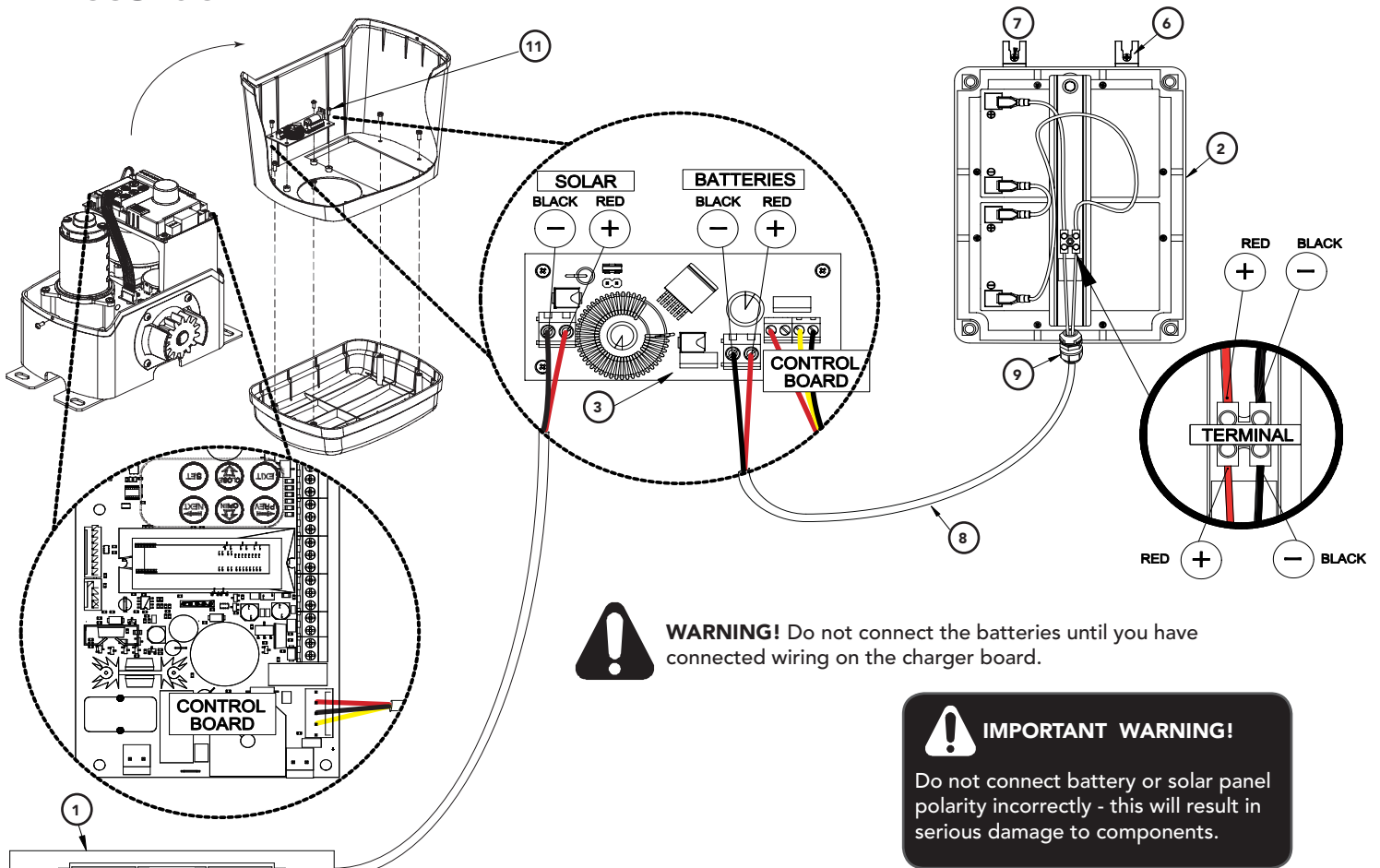

Mount the Charger Board

- Unplug the drive unit from mains power.
- Remove the main cover, then remove the transformer, EMC board (if fitted) and mains power cable.
- Mount the Charger Board inside the cover using four (4) M4x8 screws (11).
- Plug the Charger Board's three wire harness (red/yellow/black) into the control board's "SBC-02" connector.

Connect the Solar Panel

- Feed the Solar Panel's (1) cable through black grommet on the chassis.
- Connect the **red wire** to the Charger Board's (3) "SOLAR+" connector, and the **black wire** to the "-SOLAR" connector.



WARNING! The opener will become active during the following steps.

Mount & Connect the Battery

- Drill a 16.0mm hole in the Battery Pack enclosure (recommend at the bottom) and fit nylon gland (9).
- Mount the Battery Pack (2) using the mounting lugs (6) and screws (7) close to the opener.
- Feed the 2-core 18awg gauge cable (8) through the Battery Box's nylon gland (9).
- Connect the **red wire** to the Battery Box's "+" terminal, and the **black wire** to the "-" terminal
- Feed the other end of the 2-core 18awg gauge cable (8) through the drive unit's black grommet.
- Connect the **red wire** to the Charger Board's (3) "BAT+" connector, and the **black wire** to the "-BAT" connector.

Setup and Test the Opener

- Select Menu 7 on the control board, press "SET", select Sub Menu 7 ("Battery/Solar") and enable using the "OPEN" and "CLOSE" buttons.
- Setup travel limits and transmitters as per the slider instruction manual.
- Press either "OPEN" or "CLOSE" buttons, or use a transmitter to operate the gate.
- Refit the main cover.



Roll Up Door Opener Set Up

GDO-6V4 EasyRoller®, RDO-1V3

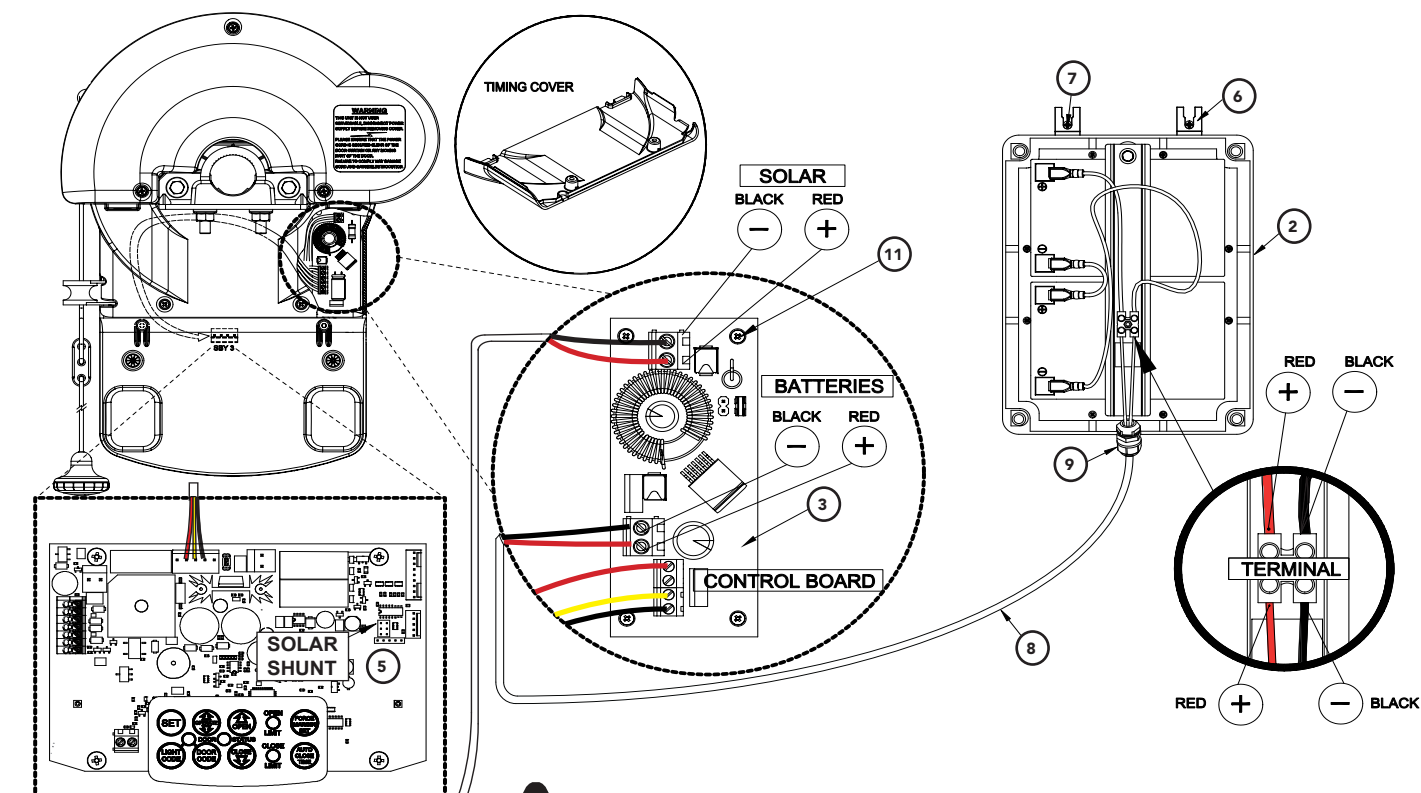

WARNING! Do not connect the batteries until you have connected wiring on the charger board.

Mount the Charger Board

- Unplug the drive unit from mains power.
- Disengage motor using manual release cord.
- Remove the main cover, timing cover and light diffuser, then remove the transformer, EMC board and mains power cable.
- Fix the Charger Board (3) under the timing cover using four (4) M4x8 screws (11).
- Feed the four wire cable attached to the Charger board (3) through the opening, then connect the three wire harness (red/yellow/black) into the control board's "SBC-02" connector.
- Plug the solar shunt (5) onto the control board's "J13" connector.

Connect the Solar Panel

- Feed the Solar Panel's (1) cable through black grommet on the chassis.
- Connect the **red wire** to the Charger Board's (3) "SOLAR+" connector, and the **black wire** to the "-SOLAR" connector.



WARNING! The opener will become active during the following steps.

Mount & Connect the Battery

- Drill a 16.0mm hole in the Battery Pack enclosure (recommend at the bottom) and fit nylon gland (9).
- Mount the Battery Pack (2) using the mounting lugs (6) and screws (7) close to the opener.
- Feed the 2-core 18awg gauge cable (8) through the Battery Box's nylon gland (9).
- Connect the **red wire** to the Battery Box's "+" terminal, and the **black wire** to the "-" terminal.
- Feed the other end of the 2-core 18awg gauge cable (8) through the drive unit's black grommet.
- Connect the **red wire** to the Charger Board's (3) "BAT+" connector, and the **black wire** to the "-BAT" connector.
- Refit the timing cover, main cover and light diffuser.

Setup and Test the Opener

- Setup travel limits and code transmitters as per the openers instruction manual.
- Press either the Operate button on the opener or use a programmed transmitter to test the opener.



IMPORTANT WARNING!

Do not connect battery or solar panel polarity incorrectly - this will result in serious damage to components.

Roll Up Door Opener Set Up

GDO-8 EasyRoller®

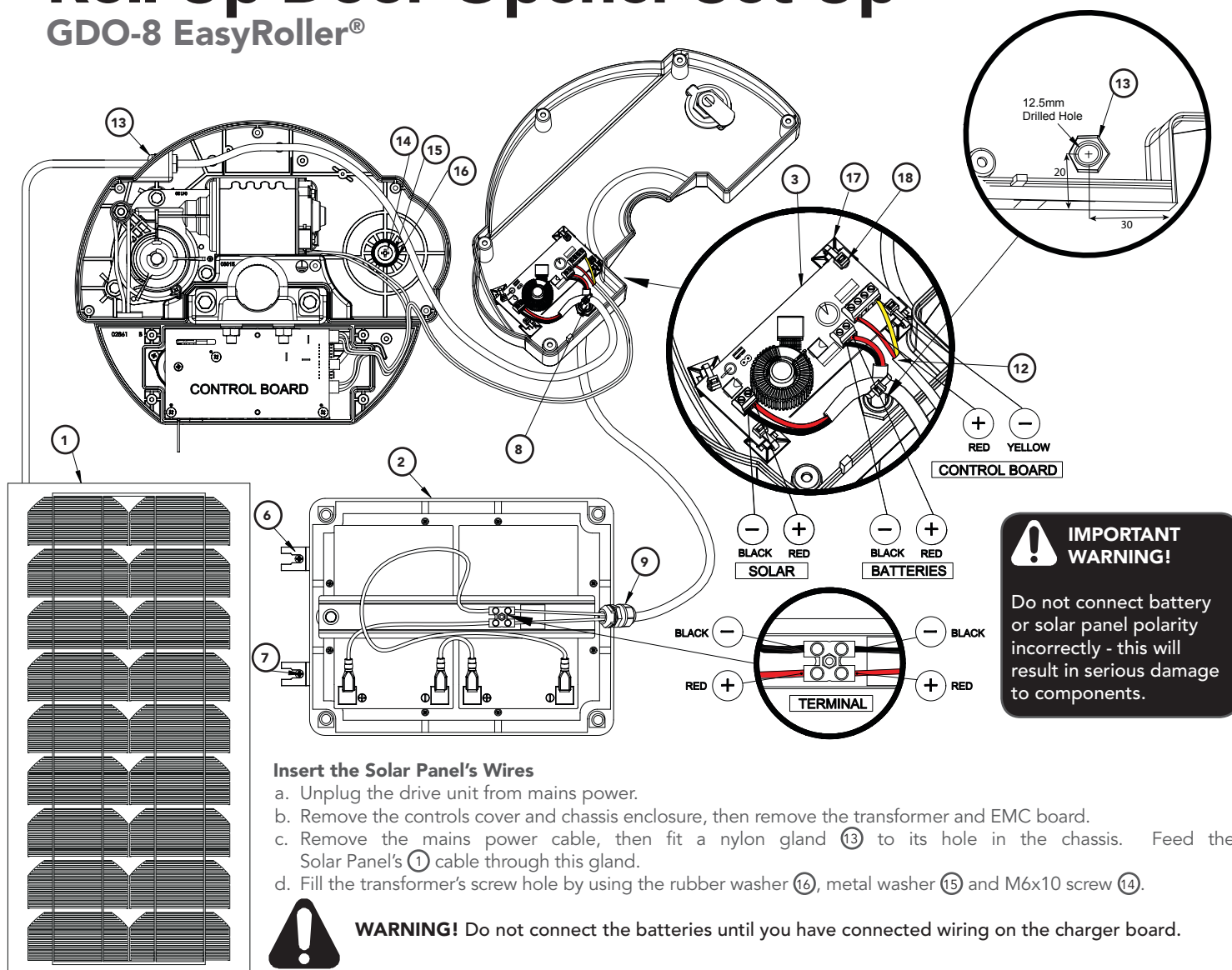

Insert the Solar Panel's Wires

- Unplug the drive unit from mains power.
- Remove the controls cover and chassis enclosure, then remove the transformer and EMC board.
- Remove the mains power cable, then fit a nylon gland (13) to its hole in the chassis. Feed the Solar Panel's (1) cable through this gland.
- Fill the transformer's screw hole by using the rubber washer (16), metal washer (15) and M6x10 screw (14).



WARNING! Do not connect the batteries until you have connected wiring on the charger board.

Mount the Battery Box

- Drill a 12.5mm hole in the chassis enclosure as shown above.
- Fit a nylon gland (13) to this hole.
- Drill a 16.0mm hole in the Battery Pack enclosure (recommend at the bottom) and fit nylon gland (9).
- Mount the Battery Pack (2) using the mounting lugs (6) and screws (7) close to the opener.
- Feed the 2-core 18awg gauge cable (8) through the Battery Box's nylon gland (9) and the nylon gland (13) in the openers chassis.
- DO NOT CONNECT THE WIRES to the Charger Board or battery terminals.



WARNING! The opener will become active during the following steps.

Mount & Wire the Charger Board

- Secure the adhesive mounts (17) to the Charger Board with cable ties (18). Affix the Charger Board (3) inside the chassis enclosure above the 12.5mm drilled hole.
- Unscrew and remove the four-wire harness from the Charger Board. Replace with the two-wire (red/yellow) harness (12), connecting wires as shown.
- Plug the two wire (red/yellow) harness (12) into the control board's "24vac supply" connector.
- Connect the **red wire** to the Charger Board's "SOLAR+" connector, and the **black wire** to the "-SOLAR" connector.
- Connect the 2 core cable to the battery by; connecting the **red wire** to the Battery Box's "+" terminal, and the **black wire** to the "-" terminal.
- Refit covers and chassis enclosures to the opener.

Setup and Test the Opener

- Setup travel limits and code transmitters as per the GDO-8 instruction manual.
- Press either the Operate button on the opener or use a programmed transmitter to test the opener.



Overhead Door Opener Set Up

GDO-9V2 GEN2 Enduro, GDO-9V3 GEN2 Dynamo,
SDO-2V2 CAD P Diamond & SDO-3V2 CAD S

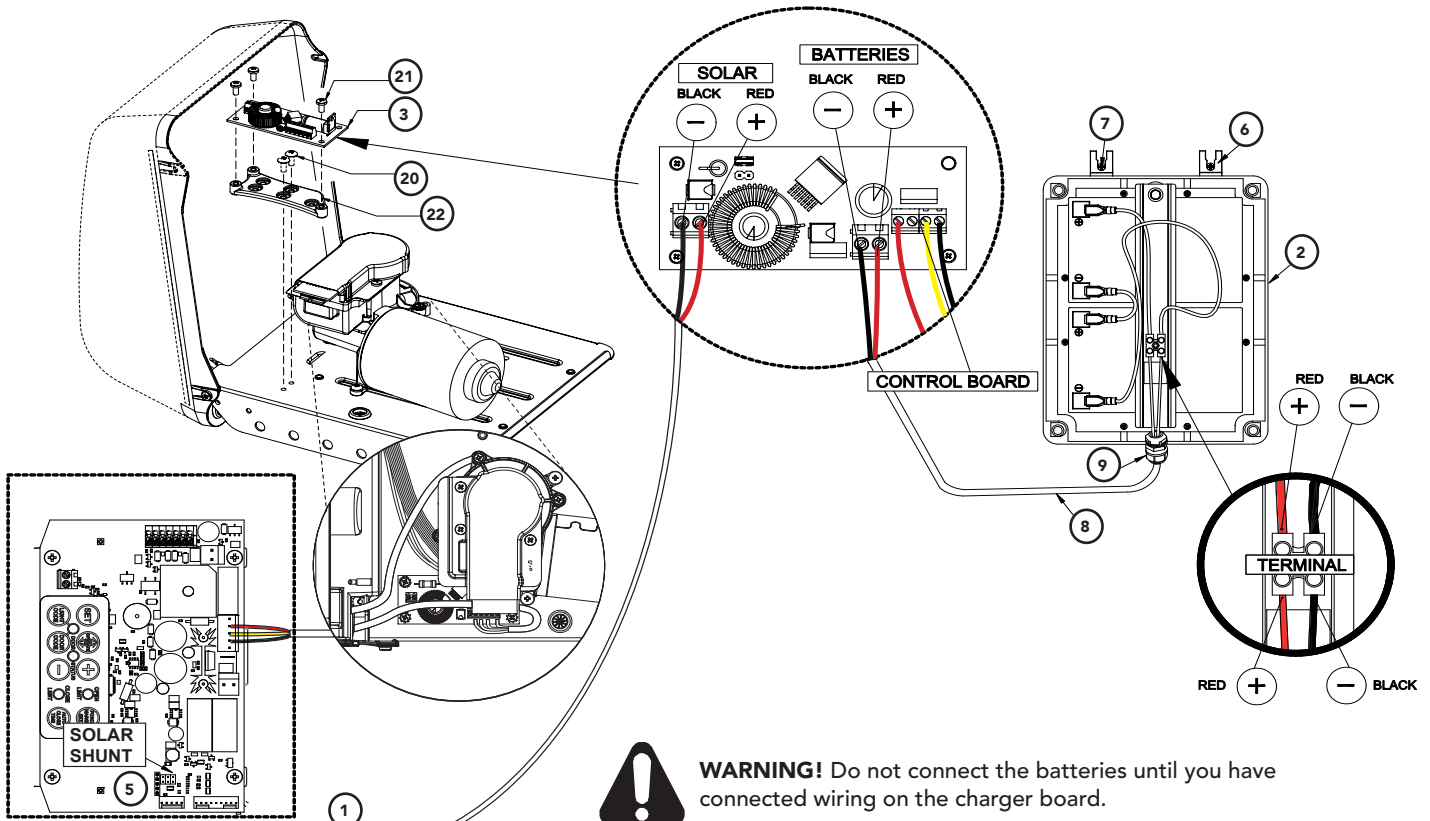

WARNING! Do not connect the batteries until you have connected wiring on the charger board.

Mount the Charger Board

- Unplug the drive unit from mains power.
- Remove the screws and swing open the main cover and remove the light diffuser.
- Remove the transformer, EMC board (if fitted) and mains power cable.
- Fit the PCB Support (22) to the base plate under the timing assembly using the two (2) M4 x 8 screws (20).
- Fix the Charger Board (3) onto the PCB Support using three (3) Taptite M4x8 screws (21).
- Feed the four wire cable attached to the Charger board (3) through the opening, then connect the three wire harness (red/yellow/black) into the control board's "SBC-02" connector.
- Plug the solar shunt (5) onto the control board's "J13" connector.

Connect the Solar Panel

- Feed the Solar Panel's (1) cable through black grommet on the chassis.
- Connect the **red wire** to the Charger Board's (3) "SOLAR+" connector, and the **black wire** to the "-SOLAR" connector.



WARNING! The opener will become active during the following steps.

Mount & Connect the Battery

- Drill a 16.0mm hole in the Battery Pack enclosure (recommend at the bottom) and fit nylon gland (9).
- Mount the Battery Pack (2) using the mounting lugs (6) and screws (7) close to the opener.
- Feed the 2-core 18awg gauge cable (8) through the Battery Box's nylon gland (9).
- Connect the **red wire** to the Battery Box's "+" terminal, and the **black wire** to the "-" terminal.
- Feed the other end of the 2-core 18awg gauge cable (8) through the drive unit's black grommet.
- Connect the **red wire** to the Charger Board's (3) "BAT+" connector, and the **black wire** to the "-BAT" connector.
- Refit the main cover and light diffuser.

Re-setup and Test the Opener

- Setup travel limits and code transmitters as per the openers instruction manual.
- Press either the Operate button on the opener or use a programmed transmitter to test the opener.



IMPORTANT WARNING!

Do not connect battery or solar panel polarity incorrectly - this will result in serious damage to components.

Specifications

| SmartSolar™V2 Technical Specifications* | | Garage Door | Slider | Swing Gate |
|--|-----------------------|--------------|-------------|---------------|
| Load Voltage | | 24 | 24 | 24 |
| Load Continuous Current | | 3 - 5A | 5A | 5 - 10A |
| Number of Cycles per Day | | 10 | 10 | 10 |
| Average Cycle Time (Opening and Closing) | | 40 seconds | 90 seconds | 72 seconds |
| Max. Standby Current | - Without P.E. Beams | 100mA | 100mA | 100mA |
| | - With P.E. Beams | 180mA | 180mA | 180mA |
| | - With 2 x P.E. Beams | | | 260mA |
| Average total consumption current per day | - Without P.E. Beams | 2.75 - 3Ah | 3.7Ah | 3.4 - 4.4Ah |
| | - With P.E. Beams | 4.66 - 4.8Ah | 5.55Ah | 5.31 - 6.3Ah |
| | - With 2 x P.E. Beams | | | 7.23 - 8.23Ah |
| Average total consumption current per hour | - Without P.E. Beams | 0.11 - 0.13A | 0.16A | 0.14 - 0.18A |
| | - With P.E. Beams | 0.194 - 0.2A | 0.23A | 0.22 - 0.26A |
| | - With 2 x P.E. Beams | | | 0.3 - 0.343A |
| Recommended storage battery capacity / voltage | | 10.5Ah/24v | 12Ah/24V | 12 - 18Ah/24V |
| Wire Gauge and Length from Battery to Charger board (max) | | 18AWG, 3m | 18AWG, 3m | 18AWG, 3m |
| Solar panel average rated output generation time per day (winter months) | | 4 hours | 4 hours | 4 hours |
| Solar Panel Output voltage / current | | 18V / 1.19A | 18V / 1.75A | 18V / 1.75A |

Important Safety Instructions



WARNING!

- **DO NOT** short the output of batteries. **Serious personal injury** and/or property damage can result from failure to follow this warning
- **DO NOT** connect battery wires incorrectly to solar charger - Observe the polarity carefully!
- During charging and discharging cycles the lead-acid batteries may release explosive gases. Ensure that the area around the batteries is well ventilated
- Take care not to allow any metal objects to make contact with the positive and negative terminals. This will short circuit the battery causing sparks and possible damage to the battery, the solar charger module, or even cause an explosion.
- **DO NOT** connect the battery box directly to solar panel.
- Install the solar charger kit in a location where it is out of reach of children.



ELECTROCUTION!

- The solar charger and battery box unit should be installed away from sprinkler systems.
- **DO NOT** immerse in water or spray directly with a hose or other device.
- **DO NOT** connect any other source of power to the opener if a SmartSolar™ kit is installed.



CAUTION:

Muscular strain

Fall from ladder

Burns

Damage

- Practice correct lifting techniques
- Ensure ladder is the correct type for job.
- Ensure ladder is on flat ground.
- Ensure user has 3 points of contact while on ladder.
- **DO NOT** handle damaged or leaking batteries
- Wear appropriate protective clothing and avoid touching your eyes after working with batteries..
- The solar charger kit contains sealed lead-acid batteries that must be disposed of properly at the end of their useful life.
- **DO NOT** bend or drop the solar panel.
- **DO NOT** use the SmartSolar™ kit to power other devices - it is specifically designed for Automatic Technology door and gate openers and some accessories only.

Warranty and Exclusion of Liability

1. This warranty is an addition to any non-excludable conditions or warranties that are implied into this contract by relevant statute, including the Trade Practices Act 1974 (Cwth).
2. Subject to all of the matters set out below, Automatic Technology Australia Pty Ltd ("ATA") warrants: SmartSolar™ kit for twelve (12) months from the date of purchase (specified in the sales docket receipt) as free of any defects in material and workmanship.
3. This warranty applies only where the purchaser:
 - a. immediately notifies ATA or the retailer of the alleged defect;
 - b. returns the product to the retailer; and
 - c. presents the relevant sales docket and this warranty document to the retailer to confirm the date of purchase.
4. Except for this warranty, ATA gives no warranties of any kind whatsoever (whether express or implied), in relation to the product, and all warranties of whatsoever kind relating to the product are, to the extent permissible by statute, hereby excluded.
5. To the extent permissible by statute, ATA disclaims any liability of whatsoever nature in respect of any claim or demand for loss or damage which arises out of:
 - a. accidental damage to or normal wear and tear to the product or to the product's components;
 - b. any cost relating to damage resulting from wear and tear;
 - c. loss or damage due to theft, fire, flood, rain, water, lightning, storms or any other acts of God;
 - d. maximum operating force exceeding 15kg (150N) when moving the door or gate manually to the open or closed position;
 - e. door surface area and/or weight exceeding 16.5m² and 100kg respectively;
 - f. residential gate weight exceeding 400kg;
 - g. door or gate not in safe and correct working order and condition;
 - h. evidence of unauthorised repairs;
 - i. any cost relating to damage caused by misuse, negligence or failure to maintain the equipment in a proper working order as per clauses (d) through (i);
 - j. installation, adjustment or use which is not in accordance with the instructions set out in installation instruction manual
 - k. attempted or complete modification or repairs to the product carried out by a person who is not authorised or has not been trained by ATA to carry out such modification or repairs;
 - l. faulty or unsuitable wiring of structure to which the product is fixed or connected;
 - m. damage caused by insects;
 - n. loss or damage to any property whatsoever or any loss or expense whatsoever resulting or arising there from or any consequential loss;
 - o. any cost or expense arising due to manufacturer recall of any product;
 - p. any cost or expense due to negligence of the approved service provider;
 - q. installation of a residential garage door or gate opener in a commercial or industrial situation or a non-single residential dwelling.
6. ATA's liability under this warranty is limited, at ATA's absolute option, to replacing or repairing the product which ATA, in its unfettered opinion, considers to be defective either in material and/or workmanship or to credit the dealer with the price at which the product was purchased by the dealer.
7. This warranty does not extend to cover labour for installation.
8. This warranty is limited to Return-to-Base (RTB) repair and does not cover labour for on-site attendance.
9. This warranty is void if the Product is not returned to the manufacturer in original or suitably secure packaging.
10. This warranty is only applicable for repairs to the product carried out within Australia.
11. This warranty does not cover consumable items including globes, batteries and fuses.
12. This warranty is not transferable.
13. Where the Product is retailed by any person other than ATA, except for the warranty set out above, such person has no authority from ATA to give any warranty or guarantee on ATA's behalf in addition to the warranty set out above.

automatic
TECHNOLOGY

6 - 8 Fiveways Boulevard, Keysborough, VIC, Australia 3173

P: 1300 133 944 E: sales@automatictechnology.com.au

W: www.automatictechnology.com.au



B&D Doors is a division of B&D Australia Pty Ltd
ABN 25 010 473 971

B&D Doors, 34-36 Marigold St, Revesby, NSW, 2212

P: 13 62 63 E: enquires@bnd.com.au

W: www.bnd.com.au