

AUTOMATIC TECHNOLOGY AUSTRALIA PTY LTD

GDO-4 EasyRoller[®]

ROLL UP GARAGE DOOR OPENER

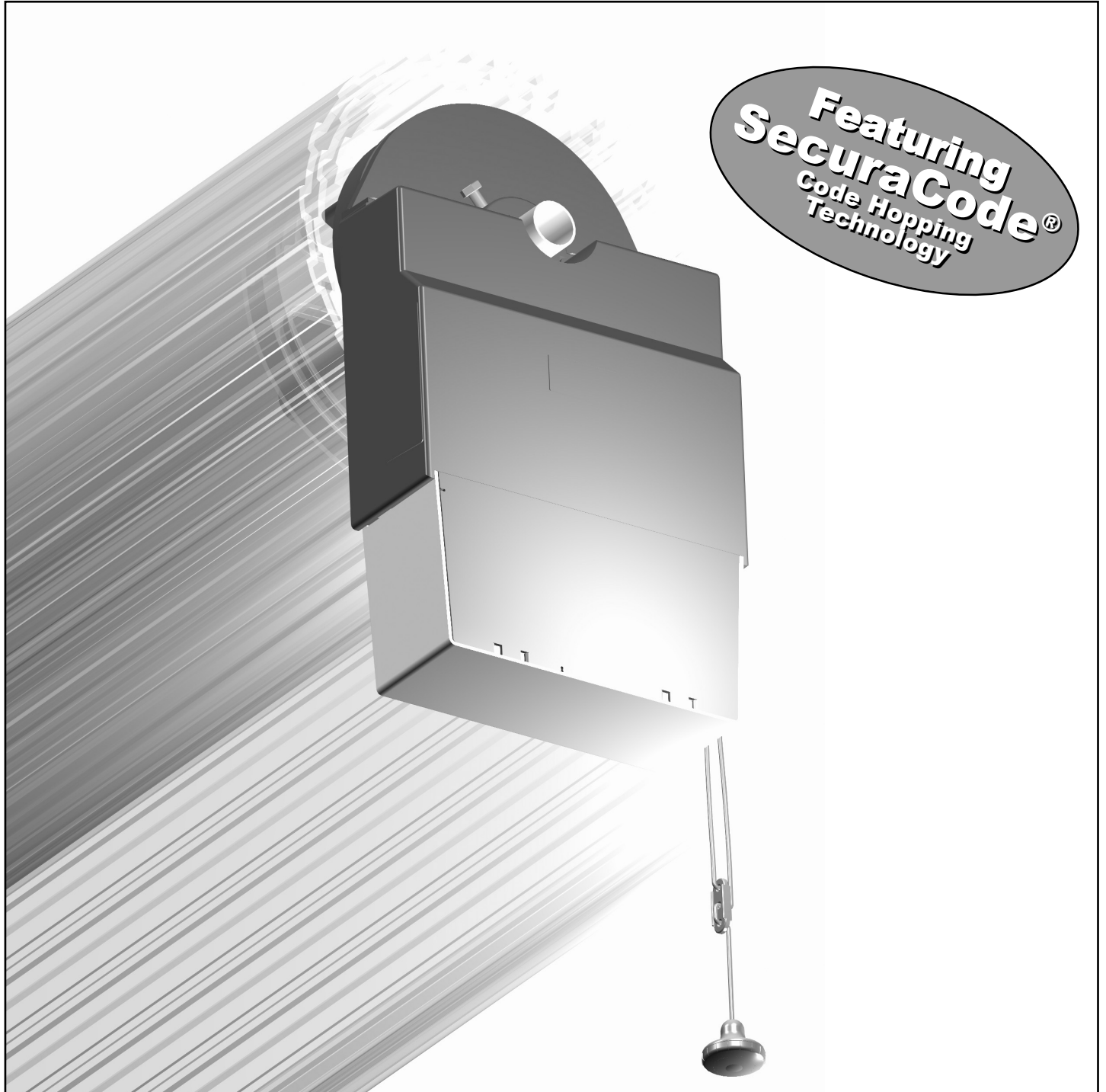





















OWNERS COPY

Installation Instructions

Warning: It is vital for the safety of persons to follow all instructions. Failure to comply with the installation instructions and the safety warnings may result in serious personal injury and/or property and remote control opener damage. Please save these instructions for future reference.

IMPORTANT SAFETY INSTRUCTIONS

Warning - It is vital for the safety of persons to follow all instructions. Failure to comply with the following Safety Rules may result in serious personal injury and/or property damage.

-  For **ADDITIONAL SAFETY** protection we **STRONGLY** recommend the fitting of a Photo Electric Beam. In most countries Photo Electric Beams are mandatory on all garage doors fitted with automatic openers. For a small additional outlay ATA recommends that Photo Electric Beams be installed with the automatic opener ensuring additional safety and peace of mind.
-  **DO NOT** operate the garage door opener unless the garage door is in full view and free from objects such as cars and children/persons. **SERIOUS PERSONAL INJURY** and/or property damage can result from failure to follow this warning.
-  **DO NOT** operate the garage door opener when children/persons are near the door. Children must be supervised near the garage door at all times when the door opener is in use. **SERIOUS PERSONAL INJURY** and/or property damage can result from failure to follow this warning.
-  **DO NOT** allow children to operate the garage door opener. **SERIOUS PERSONAL INJURY** and/or property damage can result from failure to follow this warning.
-  Regularly check to make sure that the **SAFETY OBSTRUCTION FORCE** is working correctly, and is **TESTED** (by placing a 40mm high object on the floor) and set as per the installation instruction manual. Failure to follow the manual may result in **SERIOUS PERSONAL INJURY** and/or property damage. This test must be repeated at regular intervals and the necessary adjustments made as required.
-  **DO NOT** disengage the door opener to manual operation with children/persons or any other objects including motor vehicles within the doorway.
-  Install the wall switch or wall mounted transmitter in a **LOCATION/POSITION** where it is out of reach of children and the garage door is visible.
-  The door opener is not intended for use by young children or infirm persons without adequate supervision. Young children should be supervised to ensure that they do not play with the equipment.
-  Keep hands and loose clothing **CLEAR** of the garage door and opener at all times.
-  The unit should be installed so that it is protected from the elements. It should not be exposed to water or rain. It is not to be immersed in water or sprayed directly by a hose or other water carrying device.
-  The garage door must be **WELL BALANCED**. Sticking or binding doors must be repaired by a qualified garage door installer prior to installation of the opener .
-  Frequently examine the installation, in particular cables, springs and mountings. **DO NOT** attempt to repair the door yourself as hardware is under extreme tension and can cause **SERIOUS PERSONAL INJURY** and/or property damage.
-  **REMOVE OR DISENGAGE** all garage doors locks and mechanisms prior to installation of the opener.
-  Connect the garage door opener to a properly **EARTHED** general purpose 240V mains power outlet installed by a qualified electrical contractor.
-  **DISCONNECT THE POWER CORD** from mains power before making any repairs or removing covers. Only **EXPERIENCED** service personnel should remove covers from the garage door opener.
-  When using auto close mode, a **PHOTO ELECTRIC BEAM** must be fitted correctly and tested for operation at regular intervals. **EXTREME CAUTION** is recommended when using auto close mode. **ALL SAFETY RULES** must be followed.
-  In order for the garage door opener to **SENSE** an object obstructing the door way, some **FORCE** must be exerted on the object. As a result the object, door and/or person may suffer **DAMAGE or INJURY**.
-  If the power supply cord is damaged, it **MUST** be replaced by an ATA service agent or suitably qualified person.
-  Make sure that the door is fully open before driving in or out of the garage.
-  Make sure the door is fully closed before leaving the driveway.

Automatic Technology Australia Pty Ltd to the extent that such may be lawfully excluded hereby expressly disclaims all conditions or warranties, statutory or otherwise which may be implied by laws as conditions or warranties of purchase of an Automatic Technology Australia Pty Ltd Roll Up Garage Door Opener. Automatic Technology Australia Pty Ltd hereby further expressly excludes all or any liability for any injury, damage, cost, expense or claim whatsoever suffered by any person as a result whether directly or indirectly from failure to install the Automatic Technology Australia Roll Up Garage Door Opener in accordance with these installation instructions.

FEATURES

Your EasyRoller® Automatic Garage Door Opener has many features which you will appreciate. The components and materials used in this Automatic Opener are of the latest technology and highest quality. Listed below are some of the many features.

OPERATION

To open or close the door simply press the hand held transmitter, the wall mounted transmitter, or optional wall switch for two seconds. During an open cycle the door can be stopped by pressing the button while the door is in motion. If it is interrupted during a close cycle the door will pause briefly then return to the fully open position. The next actuation will move the door in the opposite direction.

HOPPING CODE

Every time a transmission is made from the remote transmitter a new security code is generated at random. The number of possible code combinations is over 4.29 billion. This greatly enhances the security of the system making code “grabbing” a thing of the past.

ISS (INTELLIGENT SAFETY OBSTRUCTION SYSTEM)

The door will automatically reverse should it encounter an obstacle or be restricted in some manner while performing a close cycle. The amount of force the door should sense before reversing is automatically adjusted by the door's control system during the initial installation of the automatic door opener. The door will also stop if restricted whilst opening. The Safety Obstruction Force should be checked at least once a month.

SECURITY CODE STORE

The EasyRoller Garage Door Opener uses state of the art technology in storing your selected transmitter security code. Up to 27 different transmitters can be stored in the openers memory.

To store any code simply press and hold the Door Code button on the opener and press the transmitter button twice. Each or all codes can be deleted and changed at any time. The codes can also be stored via the transmitter from a remote location.

OVER LOAD INDICATOR

When the maximum opening and closing capacity of the opener is exceeded the courtesy light will flash ten times to indicate that an overload has occurred.

SERVICE INDICATOR

The opener features a service indicator. When the Overload LED flashes and the beeper sounds at the start of a door cycle, this means that the opener and/or garage door requires service.

AUTO COURTESY LIGHT

The courtesy light on the opener comes on automatically whenever the door is activated. The light can also be switched on and off without operating the door. This is done by pressing the button on any hand held or wall mounted transmitter which has been stored with the light code. The light will stay on for approximately three minutes then switch off. This time is also adjustable.

CAS (COLOUR ASSISTED SETTINGS)

To make the installation of the opener more user friendly Automatic Technology Australia has developed the CAS (Colour Assisted Settings) system. This unique colour coded system (red for close, green for open) allows for all the adjustments and settings to be easier and simpler for the user or installer to complete the installation

OPEN AND CLOSE DRIVE BUTTONS

Developed by ATA to aid the installation of the opener is the Open and Close Drive Buttons. These buttons are used to help set the open and close limit positions. A quicker setting time and a more precise limit position can be achieved by using this system.

INITIALISATION

The Reset button on the opener is used to initialise or re-initialise the obstruction force settings and door travel counters. See installation manual for instructions.

AUTO CLOSE MODE

The opener can be programmed to automatically close after an open cycle. The auto close time is adjustable. It is compulsory to install a Photo Electric Beam if this mode is selected, otherwise the door may cause personal injury or damage to property.

SAFETY AUTO RUN TIME

If the opener does not complete its cycle within thirty seconds it will automatically stop if opening, or reverse to the fully open position if closing.

PHOTO ELECTRIC BEAM (OPTIONAL)

The opener has an input for a photo electric beam to be connected for extra safety protection and use of the auto close mode.

MANUAL OPERATION

The opener is equipped with a unique patented manual disengaging device. If the power to the opener is disrupted for any reason the door can be put into manual mode by pulling down on the string handle, then releasing. This will allow you to manually open or close the door. When power is restored, by pulling down on the string handle and releasing, the opener is put back into automatic mode.

OPERATING CONTROLS

1. LIGHT CODE button (White) is used for storing or erasing the transmitter button (code) you wish to use to turn the opener's courtesy light on and off.

2. DOOR CODE button (Blue) is used for storing or erasing the transmitter button (code) you wish to use to command the door to open, stop or close.

3. CLOSE DRIVE button (Red) is used during installation to help set the close limit stop position. Pressing this button will move the door in the close direction. Movement stops when the button is released.

NOTE: The close safety obstruction detection is disabled when the Close Drive button is used to move the door.

4. CLOSE LIMIT LED (Red) the LED is very helpful during installation, it illuminates and flashes while the door is closing and remains steady on when the close limit is reached.

5. AUTO CLOSE TIME button (White) is used to adjust the auto close time. While holding Auto Close and pressing the Open button the time delay is increased (each press will increase the time by 5 seconds). Pressing the Close button will decrease the time delay.

6. RESET button is used to initialise and set the door/opener operating parameters, including cycle times and obstruction force settings.

7. O/S/C button (Yellow) is used during installation to test the Open, Stop and Close cycles for the Opener. The opener has to be initialised by the Reset button before the O/S/C button becomes operable.

8. CLOSE LIMIT ADJUST SCREW (Red) is used to fine adjust the close limit stop position.

9. OPEN LIMIT ADJUST SCREW (Green) is used to fine adjust the open limit stop position.

10. OPEN LIMIT CAM (Green) is used to set the open limit stop position.

11. OPEN Drive button (Green) is used during installation to help set the open limit stop position. Pressing this button will move the door in the open direction. Movement stops when the button is released.

NOTE: The open safety obstruction detection is disabled when the Open Drive button is used to move the door.

12. OPEN LIMIT LED (Green) the LED is very helpful during installation, it illuminates and flashes while the door is opening and remains steady on when the open limit is reached.

13. CLOSE LIMIT CAM (Red) is used to set the close limit stop position.

14. FORCE MARGIN SET button (White) is used to change the force pressure when the door encounters an obstruction. Pressing the Force Margin Set button and Open or Close button will increase or decrease the force. Normally the force pressure is set automatically. Force Margin Set is only used if other environmental factors (wind, etc.) effect the operation of the Door/Opener.

15. P.E. INPUT is for connection of Photo Electric Beams (optional extra) for extra safety obstruction protection, or compulsory when used with Auto Close mode.

NOTE: P.E. SHUNT must not be removed otherwise the opener will not function correctly. Remove only when a P.E. Beam is to be connected.

16. EXTERNAL RECEIVER INPUT is the input where an external receiver can be connected (optional extra). It can supply 30mA @ 24 volts DC maximum to power an external receiver.

17. O/S/C INPUT is for connecting the wired Wall Switch (optional extra).

18. P. E. SHUNT The shunt has to be removed when connecting a Photo Electric Beam.

19. ENGAGE/DISENGAGEMENT HANDLE when pulled down and released will select manual mode on the opener when there is a power failure. Pulling down and releasing again will switch the opener to automatic mode.

20. EASY ACCESS TRANSMITTER The "manual release" engage/disengagement handle has within its housing a wireless transmitter. If the button is pressed it will open, stop or close the garage door.

OPERATING CONTROLS

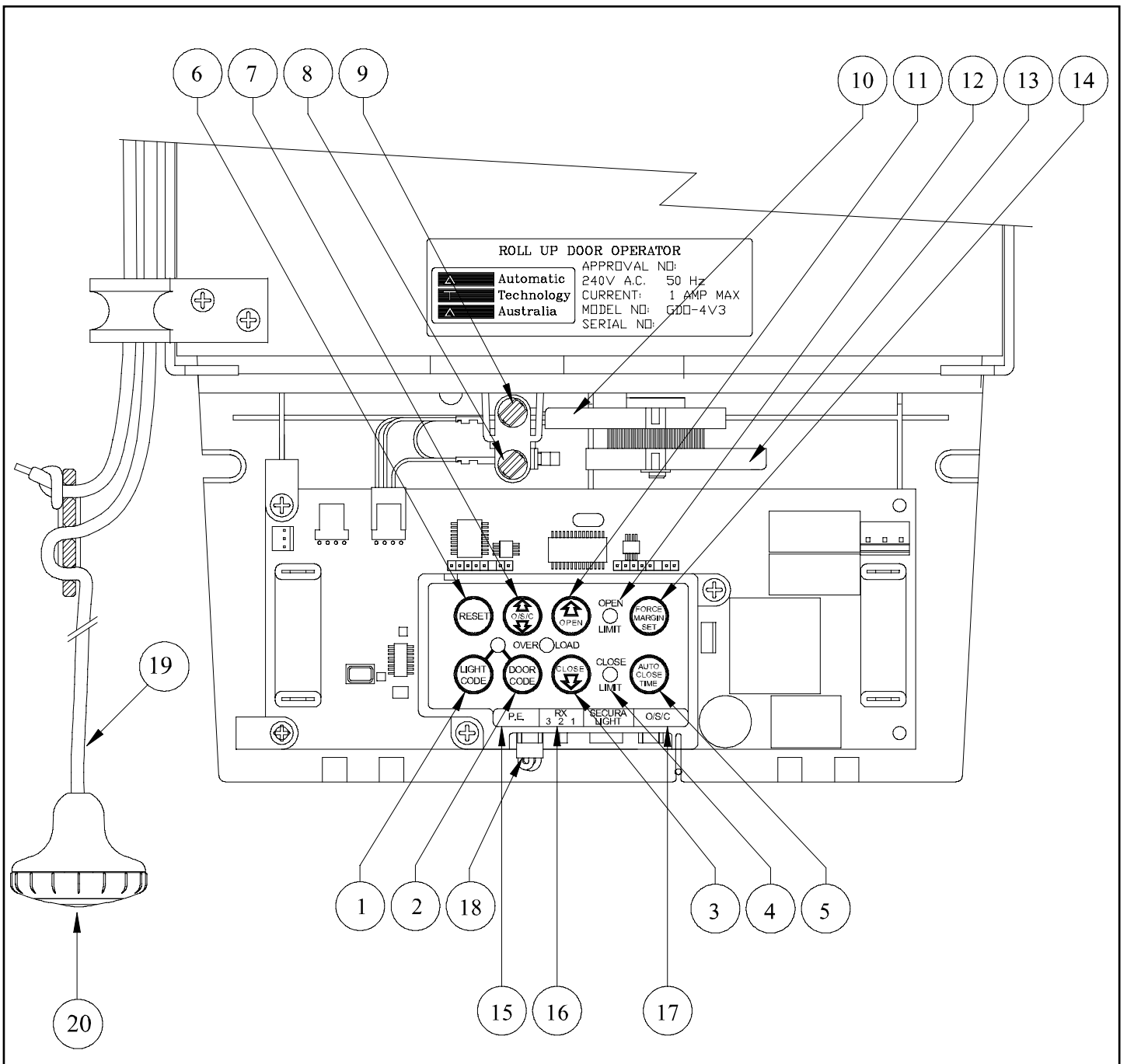

- | | |
|------------------------------------|-------------------------------|
| 1) LIGHT CODE BUTTON (WHITE) | 11) OPEN DRIVE BUTTON (GREEN) |
| 2) DOOR CODE BUTTON (BLUE) | 12) OPEN LIMIT (RED) |
| 3) CLOSE DRIVE BUTTON (RED) | 13) CLOSE LIMIT CAM (RED) |
| 4) CLOSE LIMIT LED (RED) | 14) FORCE MARGIN SET BUTTON |
| 5) AUTO CLOSE BUTTON (WHITE) | 15) P.E. INPUT |
| 6) RESET BUTTON | 16) EXTERNAL RECEIVER INPUT |
| 7) O/S/C BUTTON (YELLOW) | 17) O/S/C INPUT |
| 8) CLOSE LIMIT ADJUST SCREW (RED) | 18) P.E. SHUNT |
| 9) OPEN LIMIT ADJUST SCREW (GREEN) | 19) ENGAGE / DISENGAGE HANDLE |
| 10) OPEN LIMIT CAM (GREEN) | 20) EASY ACCESS TRANSMITTER |

PACKAGE CONTENTS

ITEM	QUANTITY
GDO-4 EASYROLLER DRIVE UNIT	1
EASY ACCESS TRANSMITTER EAT-1 (NOT INCLUDED IN SOME MODELS)	1
KEY RING TRANSMITTER PTX-4	2
PTX-4 WALL MOUNT BRACKET	1
ALKALINE BATTERY A23 12V	2
WEIGHT BARS (NOT INCLUDED IN SOME MODELS)	2
SCREW M5x40mm (NOT INCLUDED IN SOME MODELS)	4
HEX NUT M5 (NOT INCLUDED IN SOME MODELS)	4
SPRING WASHER I.D 5 (NOT INCLUDED IN SOME MODELS)	4
SCREW #6x1"	2
PLASTIC WALL PLUGS	2
INSTALLATION MANUAL	1

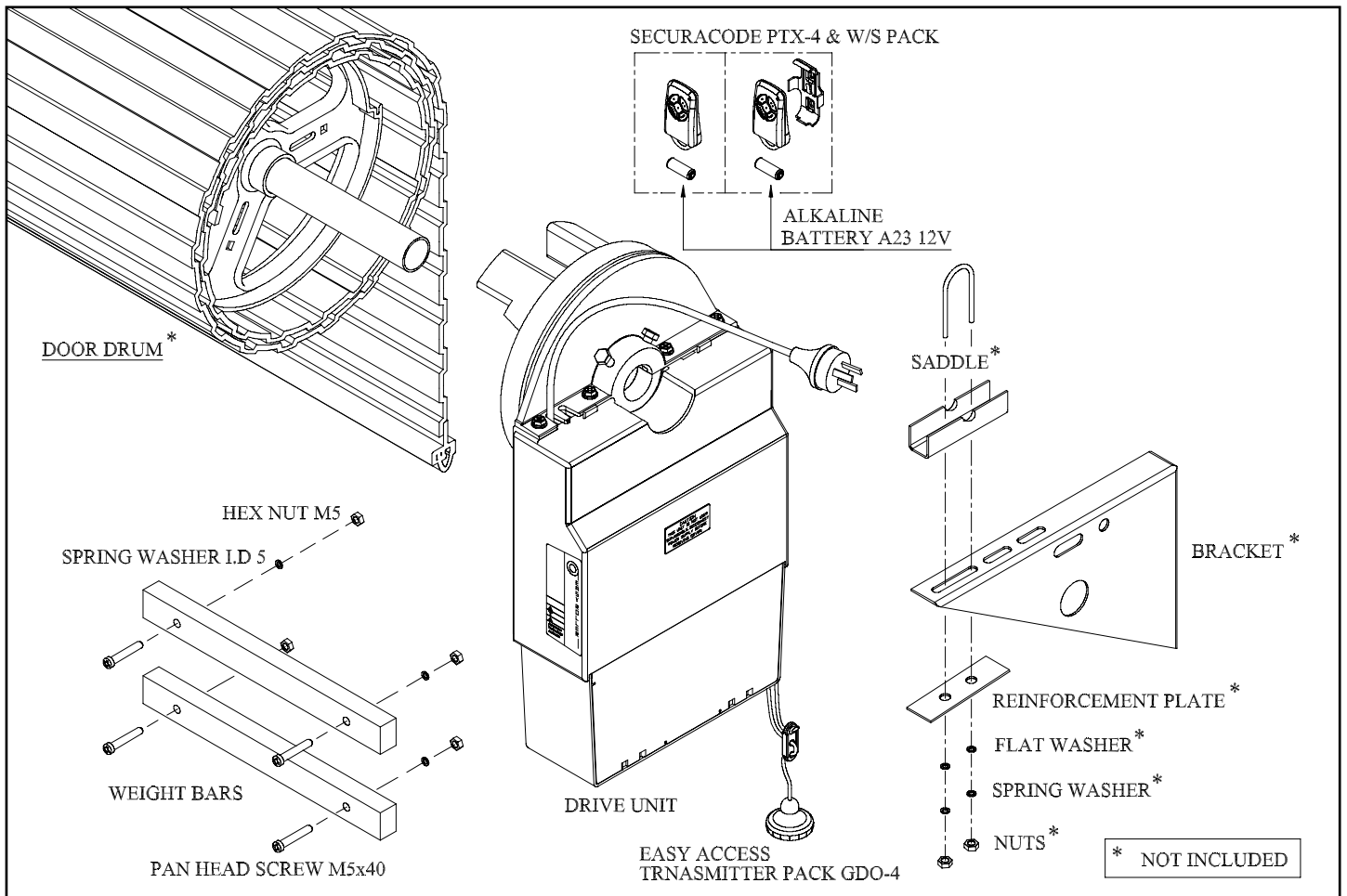

BEFORE INSTALLATION

IMPORTANT SAFETY INSTRUCTIONS FOR INSTALLATION

Warning: Incorrect installation can lead to severe injury. Follow ALL installation instructions.

SIDE ROOM REQUIREMENTS

Fig. 1 shows the minimum side room that is required. The distance between the edge of the door curtain and the inside of the bracket is 85mm minimum, and the distance between the edge of the door curtain and the outside of the bracket is 135mm minimum.

Fig. 2 shows the recommended side room. The distance between the edge of the door curtain and the inside of the bracket should be 110mm, and the distance between the edge of the door curtain and the outside of the bracket is 160mm.

1. CHECK OPERATION OF DOOR

BEFORE BEGINNING THE INSTALLATION OF THE EASYROLLER® AUTOMATIC OPENER CHECK THE OPERATION OF THE DOOR.

The door must be well balanced and be in a reasonable operating condition. You should be able to lift the door smoothly and with little resistance. It should stay open around 900mm to 1200mm above the floor. The door should not stick or bind in the guide tracks. The ideal operational effort in raising or lowering the door should not exceed a force of 10kg (22 lbs.). Make sure that all door locks are either removed, or disabled and remove unnecessary accessories.

2. FIXING OF DOOR WEIGHT BARS

Move the door manually to the mid open position. Place the weight bars equally apart on the bottom rail of the door and secure them with the fasteners provided (**Fig. 3**). Check the operation of the door again. If the door feels heavy it may require extra tension to be added to the door springs. Refer to the door Installation manual from the manufacturer on how to tension the door.

3. LEFT OR RIGHT HAND INSTALLATION

The EasyRoller Automatic Opener can be installed on the left or right hand side of the door (when looking out from the inside of the garage). If your opener is to be installed on the **RIGHT HAND** side of the door then no change needs to be made as the opener is factory set for **RIGHT HAND** installation. If **LEFT HAND** side installation is required the next step is to move the motor wire connector on the control board. The connector plug has to be removed and reconnected to the **LEFT** side of the connector (**Fig. 4**). If you have made an error in selection and wish to install to the **RIGHT HAND** side of the door, then reconnect the connector plug to the **RIGHT** side of the connector (**Fig. 5**).

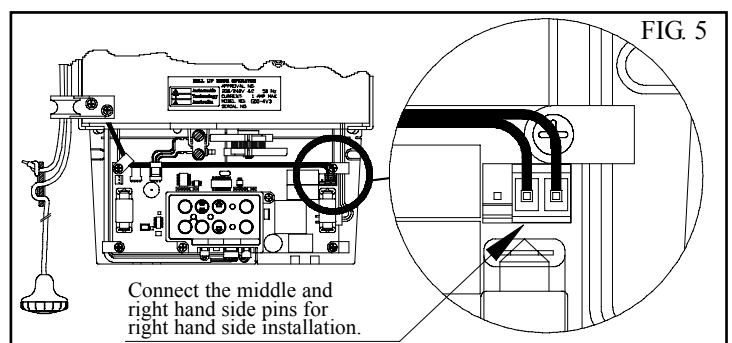
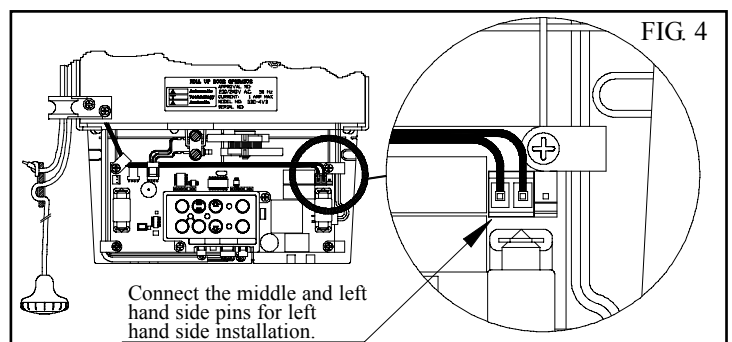
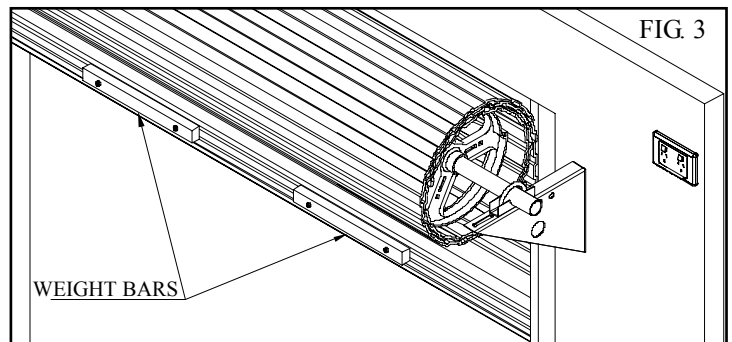
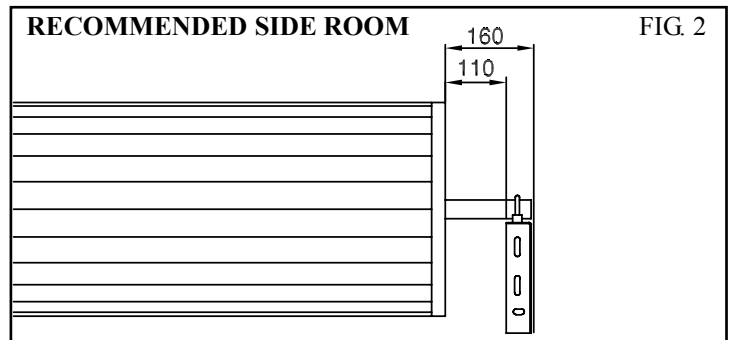
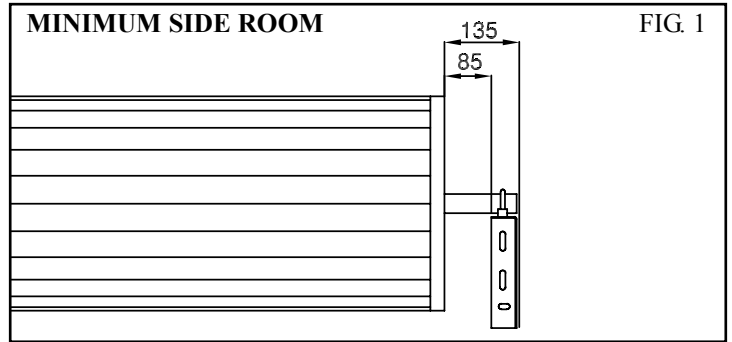

EASY ACCESS TRANSMITTER

THE EASY ACCESS TRANSMITTER

(Not available on some models)

The Easy Access Transmitter is prepared ready for use with the battery pre-installed. Before the transmitter can be operational, the Transmitter Code has to be stored into the openers memory. To store the code please follow the instructions in Step 8.1 on page 14.

REMOVING THE COVER TO REPLACE BATTERY

1. Rotate the cover Clockwise to 'OPEN'
2. Rotate the cover Anti-clockwise to 'CLOSE'

REMOVING THE BATTERY

(Battery Type: 3V Lithium Battery CR1220).

Use a non-metallic object (e.g Pen) to remove the battery.

(see **Fig. 8**)

WARNING

Metallic objects used to remove the battery may **DAMAGE** the the circuit board or the battery.

REPLACING THE BATTERY

Place one side of the battery into the battery holder (**Fig. 9**), then press the battery down firmly until it clicks into a flat position.

Note: The length of the manual release cord is user adjustable simply by sliding the plastic toggle along the cord to achieve the desired length.

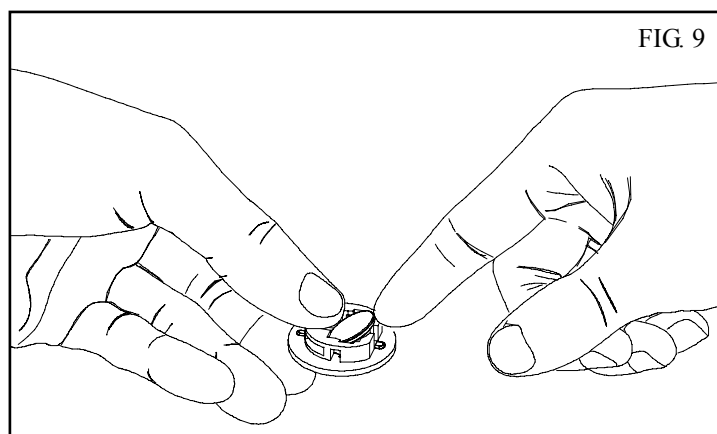
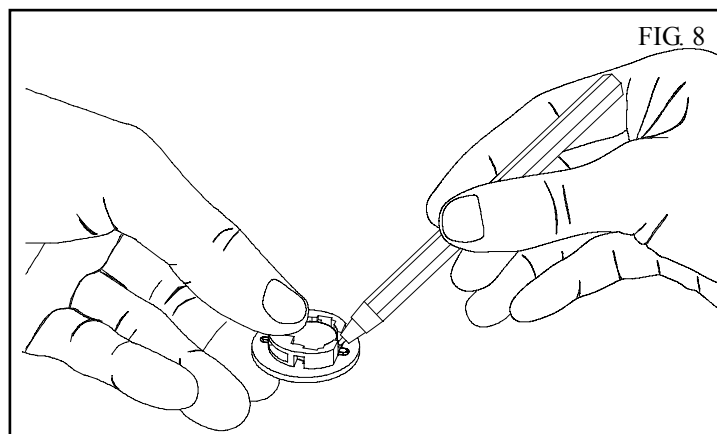
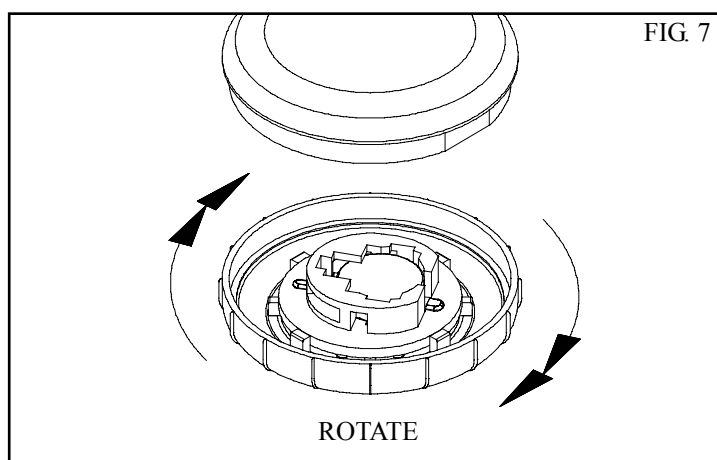
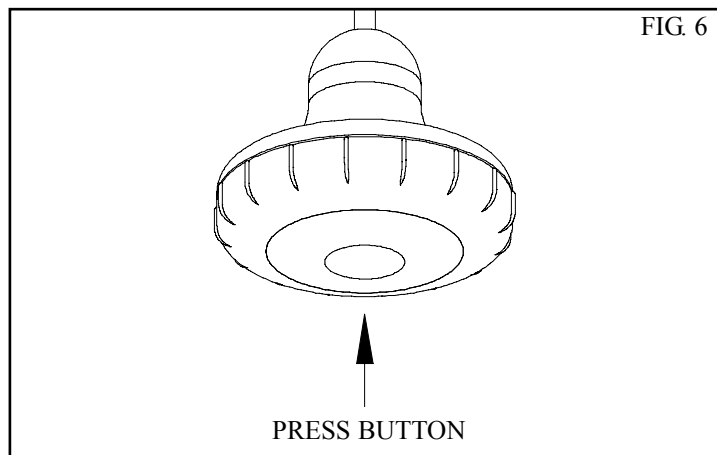

MOUNTING THE OPENER

4. FIXING DRIVE UNIT TO THE DOOR

The EasyRoller Drive Assembly can be fixed to the roll up garage door in a variety of ways. Described below is one method of fixing. Make sure there is enough side room (135mm from the end of the door shaft to the wall) to slide the drive unit onto the shaft.

PLEASE NOTE: THE INSTRUCTIONS FOR FIXING THE DRIVE ASSEMBLY TO THE DOOR IS FOR **RIGHT HAND INSTALLATION**.

FITTING DRIVE UNIT TO DOOR

(Fig. 10, Fig. 11 and Fig. 12).

1. Check that the door shaft U bolt is securely tightened on the left hand side of the door.
2. Raise the door and tie a rope around the centre to secure the roll.
3. Support the right hand end of the door with a suitable prop, e.g. step ladder and soft padding to protect the door surface.

WARNING: DO NOT ALLOW CHILDREN/PERSONS AROUND THE DOOR AND PROP. SERIOUS PERSONAL INJURY AND/OR PROPERTY DAMAGE CAN RESULT FROM FAILURE TO FOLLOW THIS WARNING.

4. Check that Steps 2 and 3 was completed. Carefully loosen and remove the right hand door shaft U bolt.
5. Make sure that the door supporting prop is secure. While the door is supported remove the right hand door mounting bracket from wall.
6. Remove the drive unit from the packaging. Try to rotate the drive gear by pushing on the fork. If the gear does not rotate manual mode has to be selected. To select pull down on the string handle, then release slowly. The drive gear should now rotate freely.
7. Slide the drive unit over the door axle making sure that the fork extends into and over one of the spokes of the door drum wheel.
8. Refit the door mounting bracket to the wall. In some cases the bracket may have to be re-positioned. Re-tighten the door shaft U bolt. Remove door supporting prop and untie the rope from the curtain.
9. Straighten the drive unit and position as per Fig. 12. Tighten the two locking bolts firmly to secure the drive unit.
10. Check the manual operation of the door by raising and lowering the door. The door should run smoothly and not catch on any part of the drive unit.
11. Adjust the length of the manual release cord so that it can be easily reached by an adult of average height (ie. less than 1.8m tall).

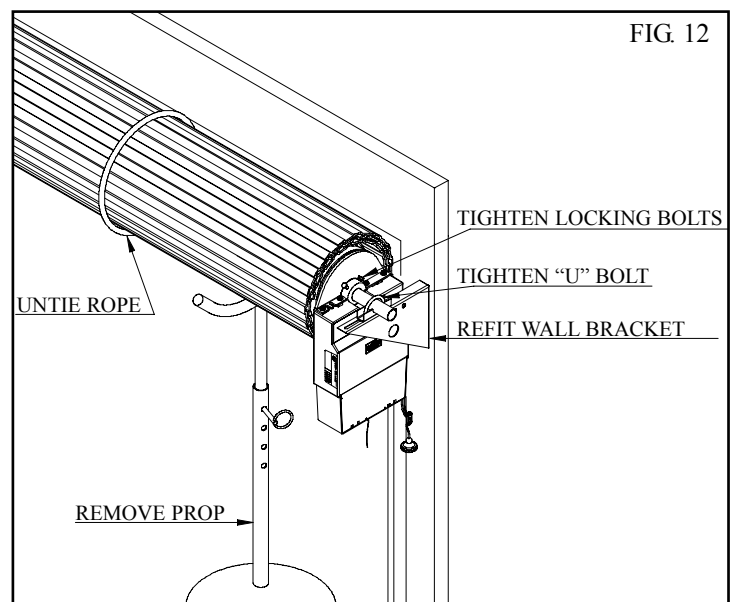
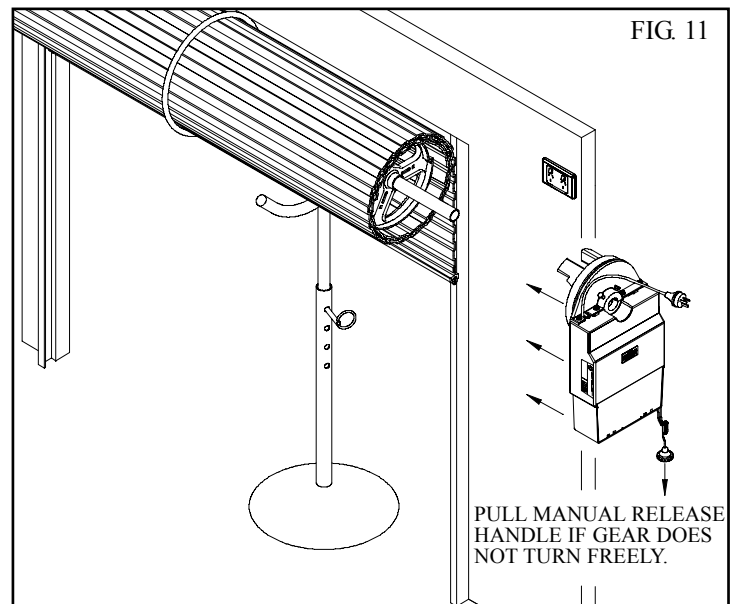
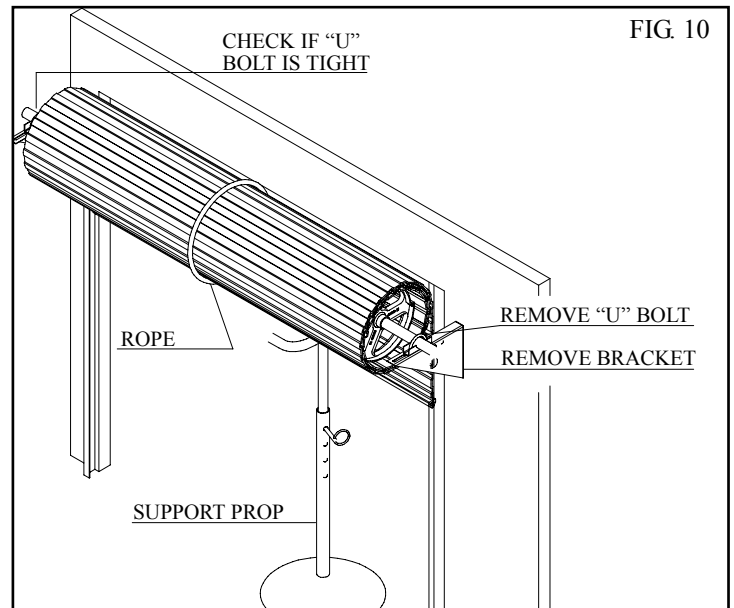

SETTING LIMITS

5. FIXING OF DOOR CURTAIN TO DRUM WHEEL

The door curtain has to be secured to the drum wheel with suitable fasteners.

1. With the door in the fully closed position, mark the curtain (Fig. 13) on both ends of the door.
2. Open door slightly to have access to the marked positions. Secure the curtain to drum wheel using self drilling screws (two on each end). The screws should be at least 90 degrees apart (Fig. 13).

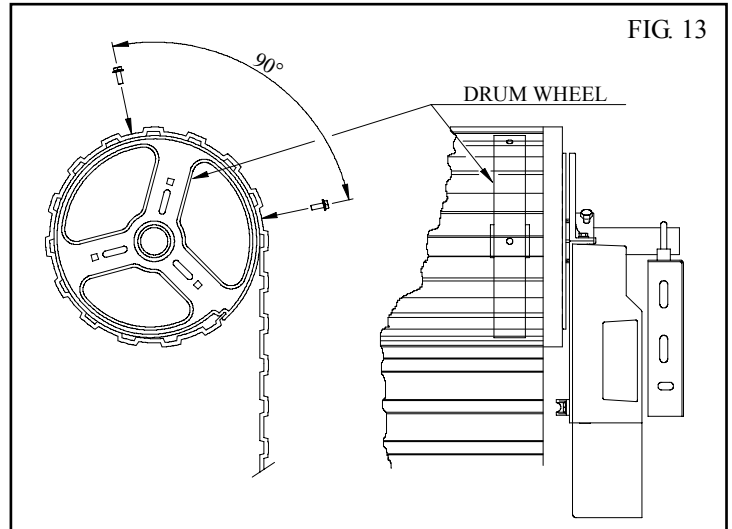

FIG. 13

6. SETTING DOOR TRAVEL LIMIT POSITIONS

IMPORTANT NOTE: The O/S/C button will not function until the open and close limits positions are set and Step 7.1 is completed.

The Limit Cams, Limit Fine Adjustment Screws and Door Inch Open and Close buttons are colour coded to make the setting of the limits as user friendly as possible.

The GREEN colours for OPEN LIMIT SETTING.
The RED colours for CLOSE LIMIT SETTING.

6.1 SETTING LIMITS FOR RIGHT HAND INSTALLATION

1. With the drive unit in manual mode (Fig. 14) move the door up by hand to the desired open position.
2. Remove the light diffuser (Fig. 14). Rotate the green limit cam by hand in an anticlockwise direction (Fig. 15) until the cam clicks the open limit switch.
3. Move the door down by hand to the desired closed position.
4. Rotate the red limit cam by hand in a clockwise direction (Fig. 16) until the cam clicks the close limit switch.
5. Connect the power lead from the drive unit into a general purpose power outlet installed by a licensed electrical contractor. Make sure that the power lead is safely fastened away from any moving parts. Turn the power on.
6. Re-engage the drive gear by pulling down on the string and then releasing slowly (Fig. 14).

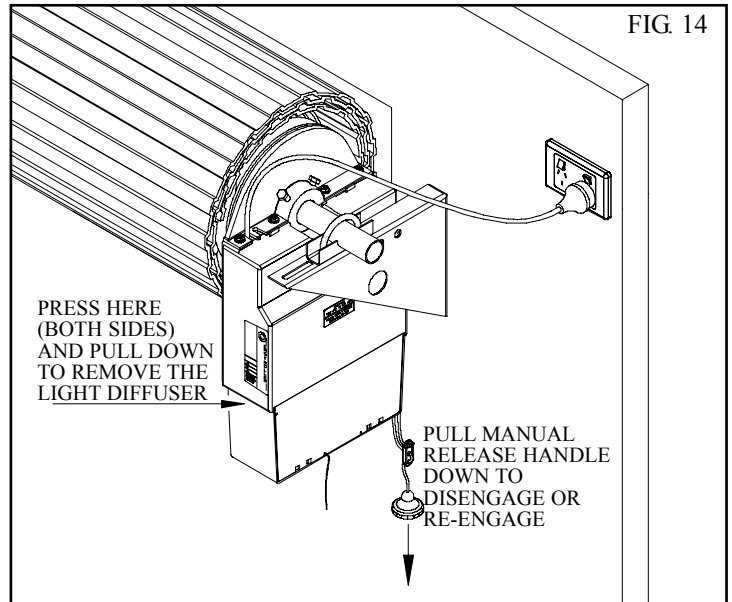

FIG. 14

OPEN LIMIT ADJUSTMENT

Press and hold the green Open button (Fig. 15) The door should start opening. Release the green Open button when the door reaches the desired open position. If the green LED (Fig. 15) is illuminated and the desired limit position has been reached then the limit adjustment is complete. If the green LED is illuminated but you are not happy with the door's open position, the green Fine Adjustment Screw (Fig. 15) can be adjusted to fine tune the open position. Turn the screw anti-clockwise to open the door more. To open the door less turn the screw clockwise. Each complete revolution of the adjustment screw is equal to approximately 10mm of door travel.

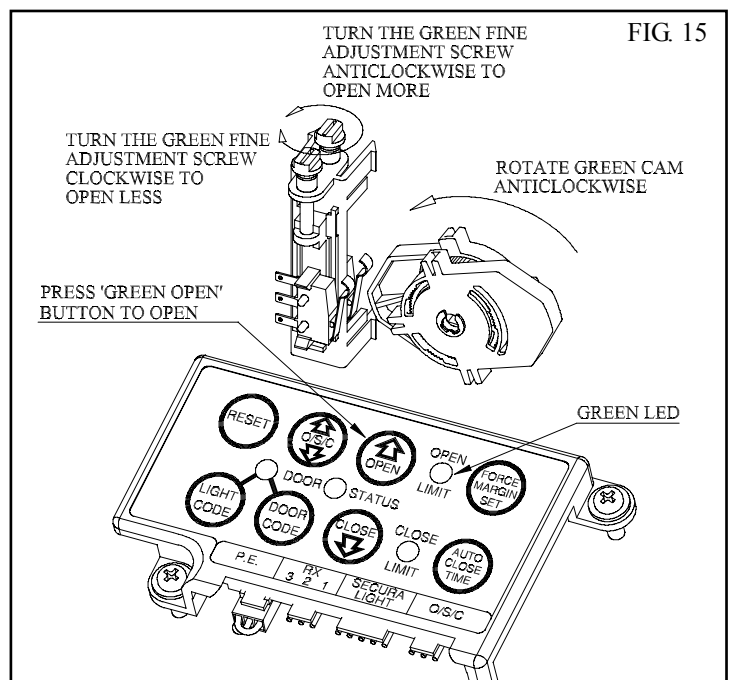

FIG. 15

SETTING LIMITS

NOTE: If the door has not reached the desired limit position by more than 30mm, then it is recommended that the green limits can be adjusted again before the green fine adjustment screw is adjusted.

CLOSE LIMIT ADJUSTMENT

Press in and hold the red Close button. (**Fig. 16**). The door should start closing. Release the red Close button when the door reaches the desired closed position. If the red LED (**Fig. 16**) is illuminated and the desired limit position has been reached then the limit adjustment is complete. If the red LED is illuminated but you are not happy with the door close position, the red Fine Adjustment Screw (**Fig. 16**) can be adjusted to fine tune the close position. Adjust the screw anticlockwise to close the door less. To close the door more adjust the red Fine Adjustment Screw clockwise. Each complete revolution of the adjustment screw is equal to approximately 10 mm of door travel.

NOTE: If the door has not reached the desired limit position by more than 30mm, then it is recommended that the red limits can be adjusted again before the red fine adjustment screw is turned.

6.2 SETTING LIMITS FOR LEFT HAND INSTALLATION

1. With the drive unit in manual mode (**Fig. 17**) move the door up by hand to the desired open position.
2. Remove the light diffuser (**Fig. 17**). Rotate the green limit cam by hand in a clockwise direction (**Fig. 18**) until the cam clicks the open limit switch.
3. Move the door down by hand to the desired closed position.
4. Rotate the red limit cam by hand in an anticlockwise direction (**Fig. 19**) until the cam clicks the close limit switch.
5. Connect the power lead from the drive unit into a general purpose power outlet installed by a licensed qualified electrical contractor. Make sure that the power lead is safely fastened away from any moving parts. Turn the power on.
6. Re-engage the drive gear by pulling down on the string and then releasing slowly (**Fig. 17**).

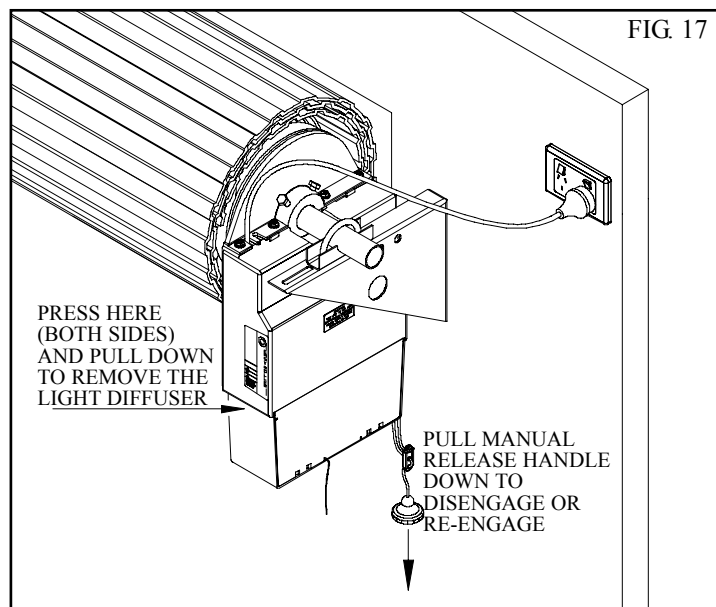
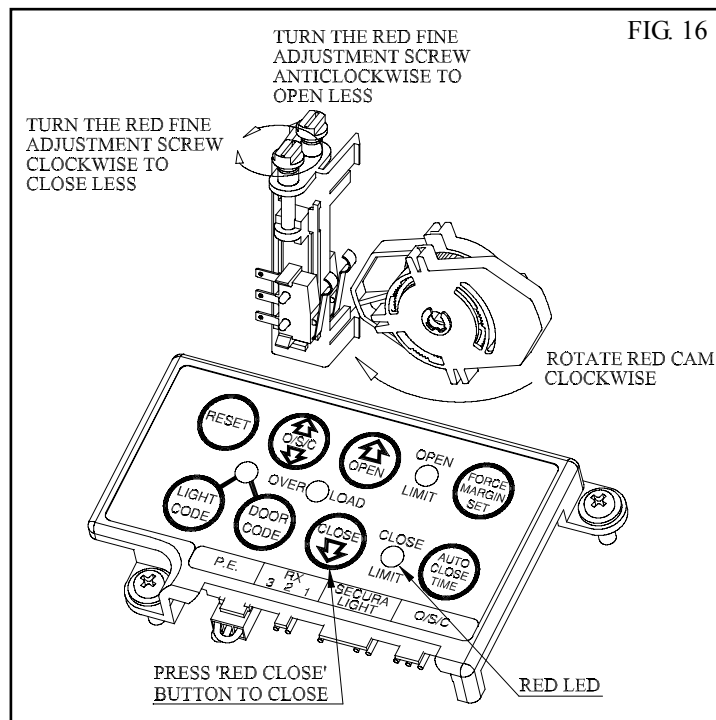

SETTING LIMITS

OPEN LIMIT ADJUSTMENT

Press and hold the green Open button (**Fig. 18**). The door should start opening. Release the Open button when the door reaches the desired open limit stop position. If the green LED (**Fig. 18**) is illuminated and the desired limit stop position has been reached then the limit adjustment is complete. If the green LED is illuminated but you are not happy with the door open position, the green Fine Adjustment Screw (**Fig. 18**) can be adjusted to fine tune the open position. To open the door more, turn the Green Fine Adjustment Screw clockwise. To open the door less turn the Green Fine Adjustment screw anticlockwise. Each complete revolution of the adjustment screw is equal to approximately 10mm of door travel.

NOTE: If the door has not reached the desired limit position by more than 30mm, it is recommended that the green limit cam be adjusted again before the green fine adjustment screw is turned.

CLOSE LIMIT ADJUSTMENT

Press and hold the red Close button (**Fig. 19**). The door should start closing. Release the Close button when the door reaches the desired closed limit stop position. If the red LED (**Fig. 19**) is illuminated and the desired limit position has been reached then the limit adjustment is complete. If the red LED is illuminated but you are not happy with the door close position, the red Fine Adjustment Screw (**Fig. 19**) can be adjusted to fine tune the close position. Turn the screw clockwise to close the door less. To close the door more turn the screw anticlockwise. Each complete revolution of the adjustment screw is equal to approximately 10mm of door travel.

NOTE: If the door has not reached the desired limit position by more than 30mm, then it is recommended that the red limit cam be adjusted again before the red fine adjustment screw is turned.

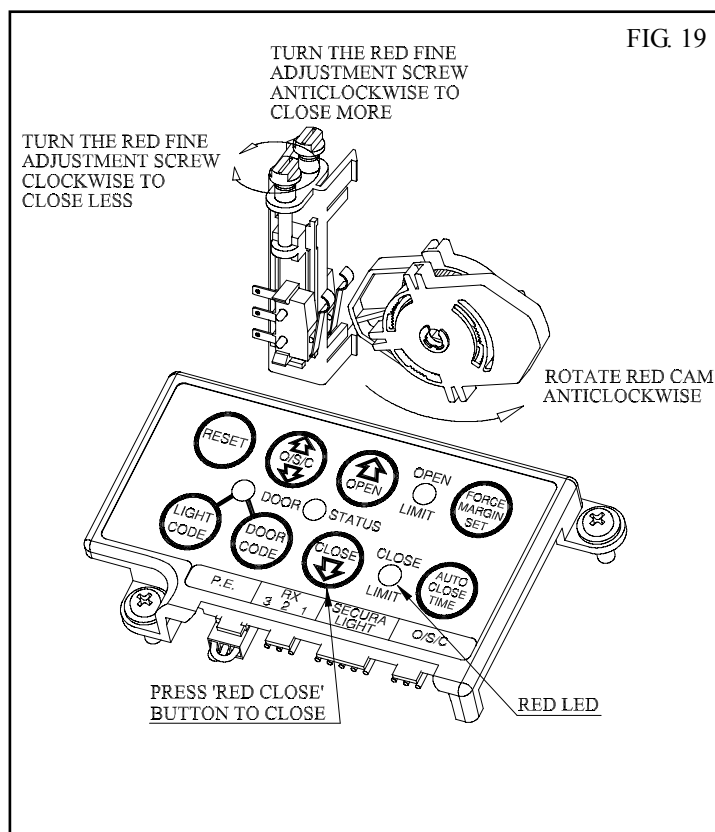
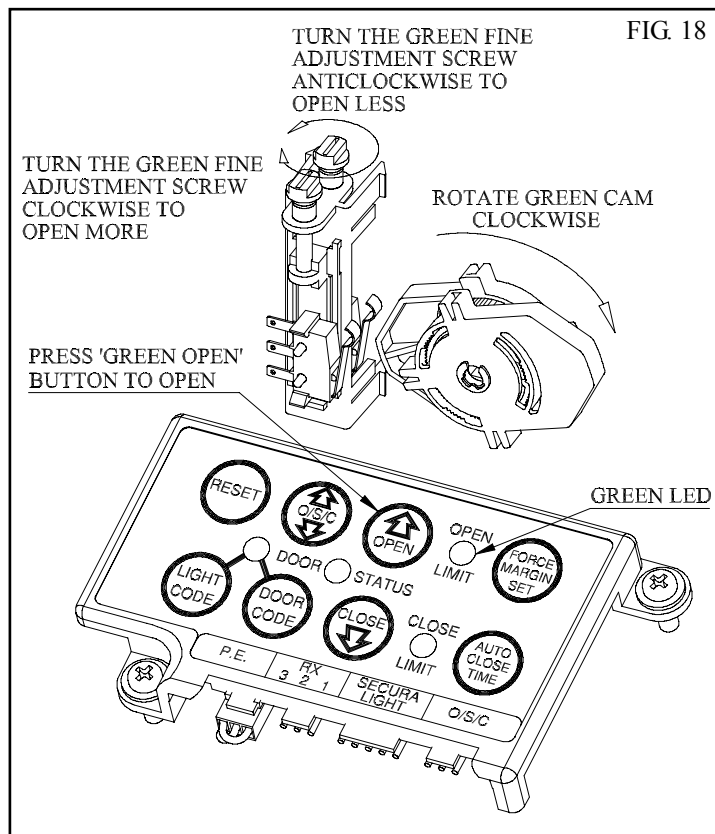

SETTING SAFETY OBSTRUCTION FORCE

7. SETTING OPEN AND CLOSE SAFETY OBSTRUCTION FORCE

The Safety Obstruction Force is calculated automatically and set in memory on the EasyRoller. This applies to both the Open Force and Close Force.

Warning: When step 7.1 is initiated the garage door will do a full open and close cycle automatically. Please keep doorway clear to avoid any personal injury or damage to property.

7.1 TO INITIALISE OBSTRUCTION FORCE

1. Press and hold the Close button (**Fig. 20**) to move the door to the fully closed position. Check that the red LED is steady ON, to confirm the door is set on the closed limit position
2. Press the Reset button (**Fig. 20**) for two seconds, the door should start opening. When the door reaches the fully open position it will pause momentarily then start to close. The door has to do a complete open and close cycle without interruptions for the safety obstruction parameters to be calculated and set automatically.

A default safety force margin is preset in the factory. Under normal operating conditions this default margin should not be changed. If you are not satisfied with this setting you can adjust it as per the procedure below.

IMPORTANT NOTE:

Whenever the limit switches or cams are adjusted the safety obstruction force has to be re-initialised because the door's travel distance may have changed. To re-initialise the door follow STEP 7.1 above.

7.2 TO INCREASE FORCE PRESSURE

1. Press and hold the Force Margin Set button (**Fig. 20**).
2. While holding Force Margin Set press the green Open button. The green LED will illuminate each time the green open button is pressed to indicate that the force pressure is being increased. If the green LED flashes continuously when the open button is pressed, this indicates that the maximum force pressure setting has been reached.

7.3 TO DECREASE FORCE PRESSURE

1. Press and hold the Force Margin Set button (**Fig. 20**).
2. While holding down button press the red Close button. The red LED will illuminate each time the Close button is pressed, to indicate that the force pressure is being reduced. If the red LED flashes continuously when the close button is pressed, this indicates that the minimum force pressure setting has been reached.

7.4 TO RECALL FACTORY SET FORCE

1. While holding the Force Margin Set button press the RESET button for two seconds.
2. Release both buttons. The default setting should now be recalled.

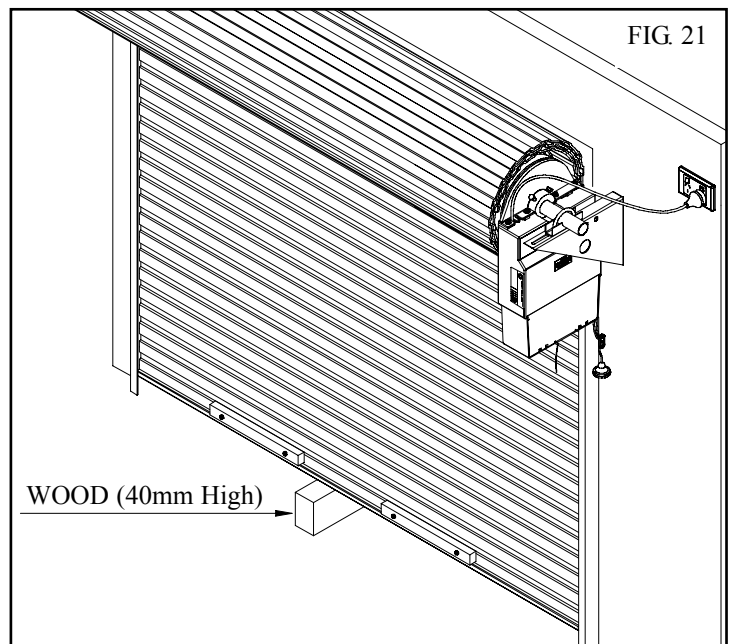
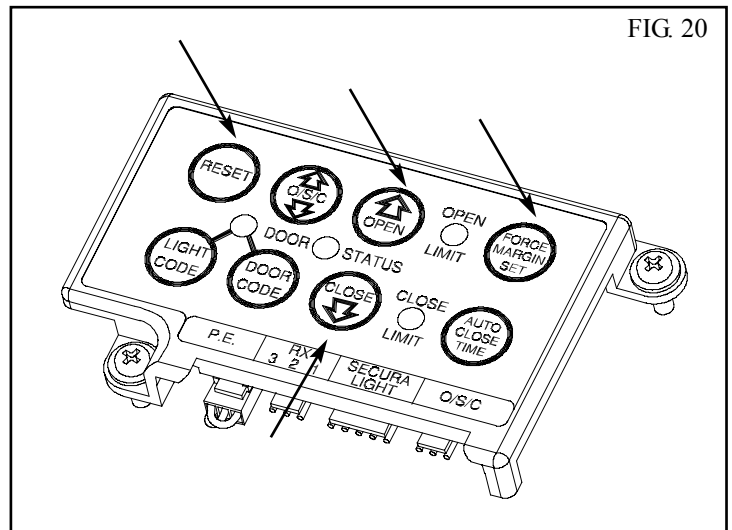

7.4 SAFETY OBSTRUCTION TEST TESTING CLOSE CYCLE

1. Open the door by pressing the Yellow O/S/C button (**Fig. 20**).
2. Place a length of timber 40mm high on the floor directly under the door (**Fig. 21**).
3. Press the Yellow O/S/C button to close door. The door should strike the object and start to re-open.

TESTING OPEN CYCLE

1. Close the door by pressing the Yellow O/S/C button. (**Fig. 20**).
2. Press again to open the door. When the door opens half way grab the bottom rail of the door firmly, the door should stop.

If the door does not reverse readily when closing, or stop when opening, the force may be excessive and need adjusting, refer to STEP 7.1, 7.2, 7.3 and 7.4.

IMPORTANT WARNING: If the door is closing and is unable to re-open when obstructed discontinue use. Do not use a door with faulty obstruction sensing. Repair fault and re-test before using.

CODING TRANSMITTERS

8. STORING TRANSMITTER CODES

Make sure to connect the battery to the transmitters. The memory in the opener's receiver can store up to 27 different remote control transmitters.

8.1 STORING TRANSMITTER CODE

1. Press and hold the Door Code button (Fig. 22).
2. Press the button (one of four) on the transmitter you would like to use to control the door for two seconds.
3. Pause for two seconds. Press the same button again on the transmitter for two seconds.
4. Release the Door Code button.
5. Press the transmitter button to test if it operates the door.

9. STORING TRANSMITTER(S) FROM A REMOTE LOCATION

Using this method you don't need to have access to the control panel on the door opener. However, you do need a transmitter that is pre-coded to the opener's receiver.

IMPORTANT NOTE: The door or courtesy light will be activated when the step below is performed. The door moving or light switching on is to confirm, from a remote location, that the correct button was pressed and the transmitter is in range of the opener.

1. Take any pre-coded transmitter. Press the button for the function you require until the door is activated and release.
2. Then using a small needle press through the Coding Hole and hold firmly for two seconds (Fig. 23)
3. Within 10 seconds take the additional transmitter you wish to code.
4. Press the button (one of four) on that transmitter you would like to use to control the door for two seconds, pause for two seconds. Press the same button again on the transmitter for two seconds, the button should now be recorded.
5. Wait for 10 seconds and then press the recorded transmitter button to confirm that it operates the door.

10. INSTALLING WALL MOUNTED TRANSMITTER BRACKET

1. Mount the bracket in a location out of reach of children and convenient to the customer. (Fig. 24). Make sure the door is visible from this location.
2. The transmitter can be easily clipped in and removed from the holder as required.
3. To set the transmitter codes refer to Step 8.

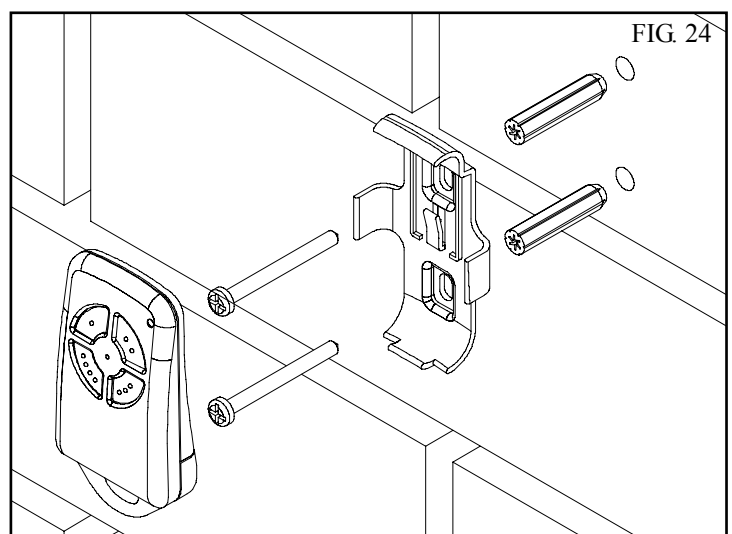
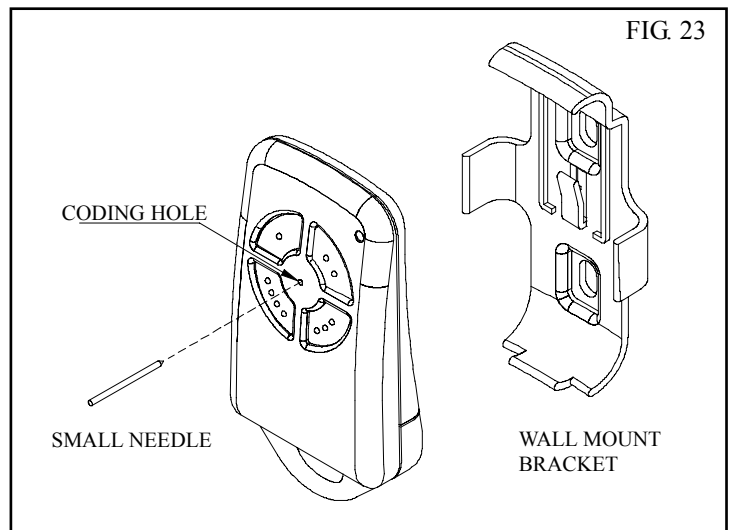
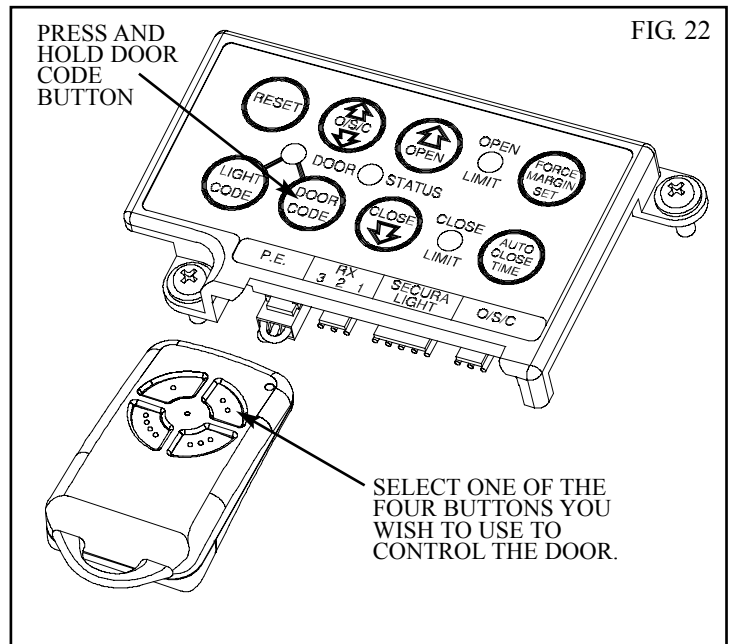

CODING TRANSMITTERS

11. SETTING THE TRANSMITTER TO OPERATE THE COURTESY LIGHT

The transmitter can be programmed to operate the courtesy light on the door opener.

1. Press and hold Light Code button (**Fig. 25**).
2. Press the button on the transmitter you would like to use to switch on the light for two seconds
3. Pause for two seconds. Press the same button again on the transmitter for two seconds.
4. Release all buttons to store the transmitter in memory.
5. Press the transmitter button to test if it switches on the light.

12. ADJUSTING COURTESY LIGHT TIME

The preset courtesy light time on the Door Opener is 3 minutes. This time can be changed as below.

1. Press and hold the Auto Close Time and Force Margin Set buttons together (**Fig. 26**).
2. While holding the two buttons, press the green Open button (**Fig. 26**). Each press will add 10 seconds to the light time.
3. To decrease the time follow step 1 and press the red Close button (**Fig. 26**). Each press will deduct 10 seconds from the light time.
4. To recall the factory set default light time press and hold the Auto Close Time, Force Margin Set and Reset buttons together for about 2 seconds. (**Fig. 26**).

13. DELETING PROGRAMMED CODES

13.1 DELETING A STORED TRANSMITTER CODE

1. Select the transmitter you want to delete.
2. Press and hold the Door Code button (**Fig. 27**).
3. Press the transmitter button you would like to delete for two seconds.
4. Pause for two seconds. Press the transmitter button again for two seconds.
5. Release the Door Code button. The code should now be deleted. Confirm this by pressing the transmitter button, the door should not respond.

13.2 DELETING ALL STORED TRANSMITTER CODES

1. Turn the power off to the opener.
2. Press and hold the Door Code button (**Fig. 27**).
3. Turn the power on again, while holding the Door Code button. The Coding LED will illuminate to indicate that the receivers memory has been deleted.
4. Release the Door Code button. All the stored codes including the courtesy light codes should now be deleted. Confirm this by pressing the transmitters previously used to operate the door, the door (and light) should not respond.

FIG. 25

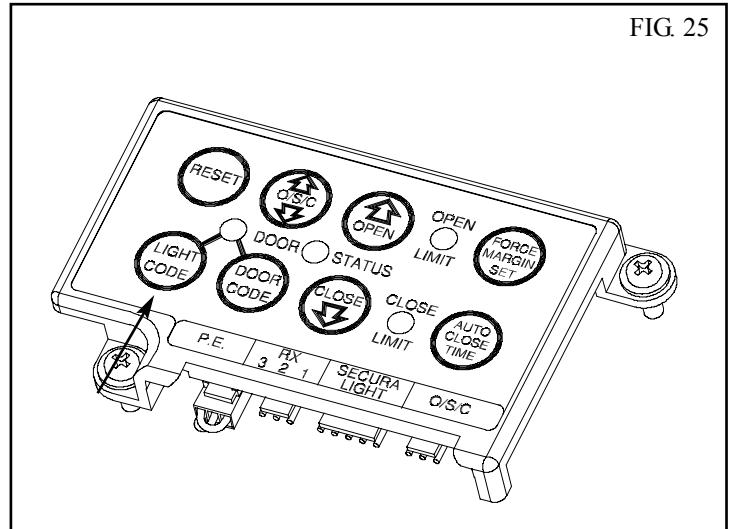

FIG. 26

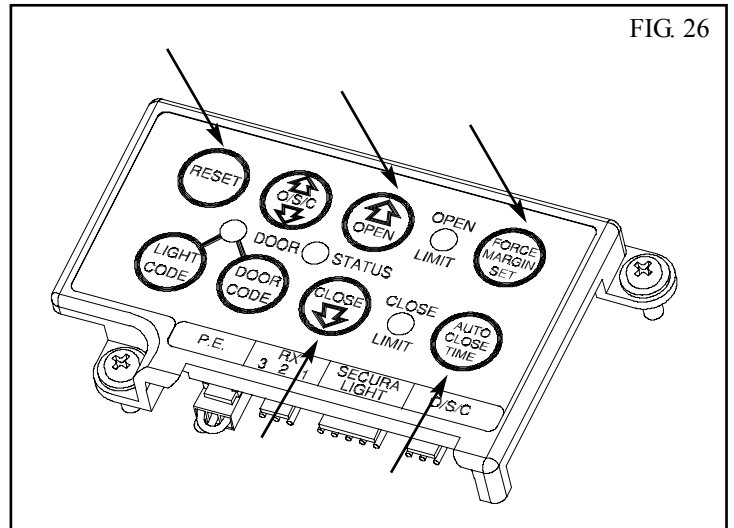
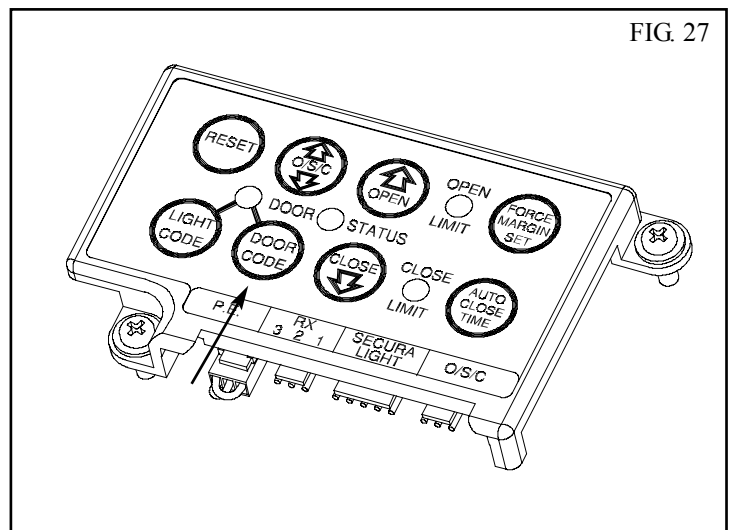

FIG. 27



PE BEAM AND AUTO CLOSE

14. FITTING THE SAFETY PHOTO ELECTRIC BEAM SENSOR (OPTIONAL)

Locate the Photo Electric Beam (P.E.) normally closed contact type in a strategic location within doorway. We recommend 150mm above the floor level and as close as possible to the door opening, inside the garage. Remove shunt from P.E. connector (Fig. 28) and connect the plug from the P.E. wiring harness to P.E. connector (Fig. 29). The wiring diagram is for Model PHBE (Order Code 90214).

Make sure to align the beams correctly. Follow the manual supplied with the Photo Electric Beam.

WARNING; When using Auto Close Mode and P.E. beams, the doorway must be clear of all obstructions and persons at all times. The location of the beam and manner in which it is installed might not give safety protection at all times. Check to make sure that the height of the beam and type used give maximum protection possible.

15. SETTING AUTO CLOSE TIME

IMPORTANT NOTICE: IT IS COMPULSORY TO INSTALL A PHOTO ELECTRIC BEAM BEFORE USING THE AUTO CLOSE MODE.

The Auto Close timer will only start after the Photo Electric Beams (P.E.) path is broken and the auto close time has been set. If the P.E. path is not broken the door will remain open until the path is broken. If the door opener incurs an obstruction (not from the P.E.) while closing the door will re-open and not auto close until the path of the P.E. beam is broken again.

1. Press and hold the Auto Close Time button (Fig. 28).
2. While holding the Auto Close Time button, press the Open button (Fig. 28). Each press of this button will add five seconds to the auto close delay time.
3. To decrease the delay time follow Step 1 and press the Close button. Each press will deduct five seconds from the auto close time.
4. Press the O/S/C button (Fig. 28) or transmitter to open the door. When the door is fully opened the Open Limit green LED will flash to indicate that the auto close mode is in operation.
5. Break the path of the P.E. Beam momentarily, this will initialise the auto close mode. The door will close once the set auto close time has elapsed.

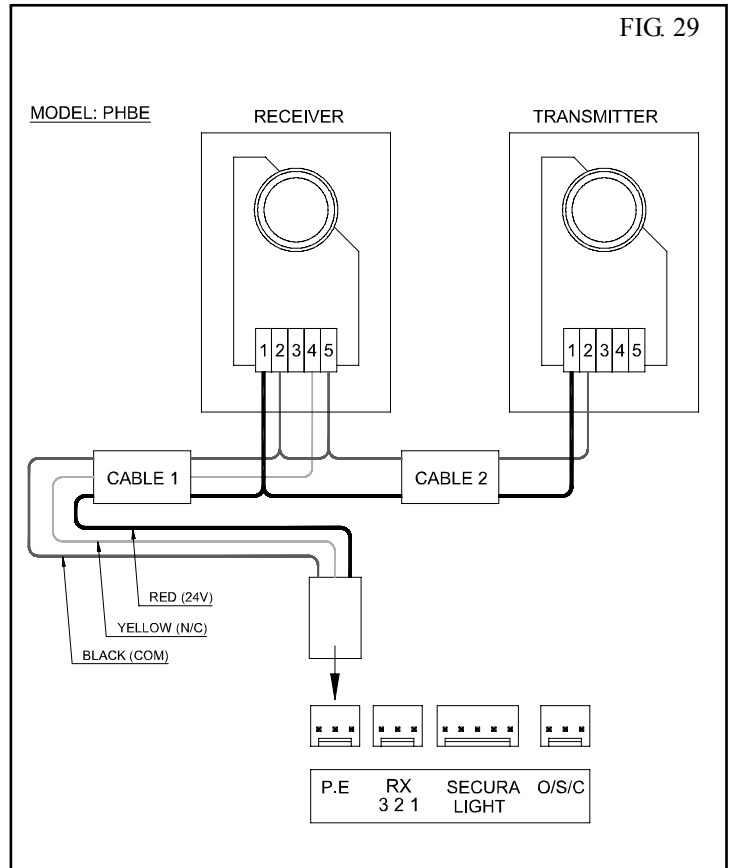
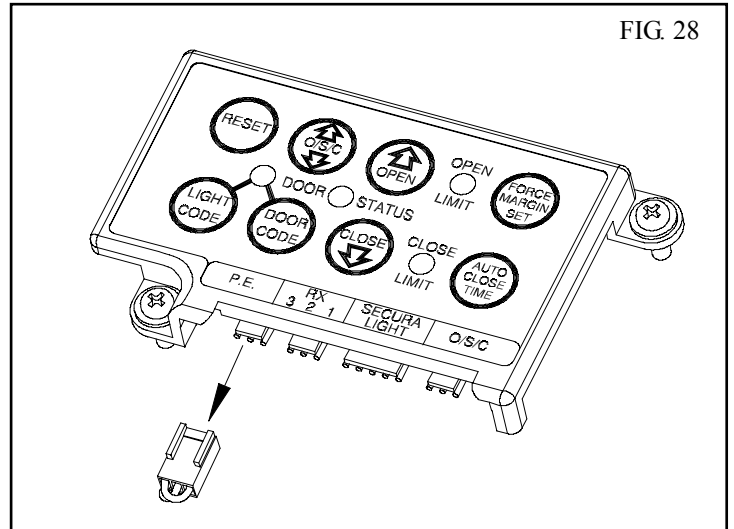

FACTORY DEFAULT SETTINGS

	DEFAULT	STEP	MAXIMUM
MAXIMUM MOTOR RUN TIME	30 Secs.	—	—
COURTESY LIGHT TIME	3 Mins.	10 Secs.	10 Mins.
OBSTRUCTION FORCE MARGIN	10	1	20
AUTO CLOSE TIME	0 Secs.	5 Secs.	4 Mins.

PARAMETERS & SPECIFICATIONS

DOOR STATUS INDICATORS

DOOR OPENER STATE	OPEN LED GREEN	CLOSE LED RED	DOOR STATUS LED YELLOW	BEEPER
OPEN	ON			
CLOSE		ON		
OPENING	FLASHING			
CLOSING		FLASHING		
DOOR TRAVEL STOPPED	FLASHING	FLASHING		
DOOR OBSTRUCTED WHEN OPENING	FLASHING			
DOOR OBSTRUCTED WHEN CLOSING		FLASHING		BEEPS WHILE DOOR IS MOVING
DOOR OVERLOADED	ALTERNATING FLASHES	ALTERNATING FLASHES		
DOOR IN OPEN POSITION WITH AUTO CLOSE MODE SELECTED	ONE SECOND FLASHES			
MAINS POWER INTERRUPTED	RAPID FLASHES			

TECHNICAL SPECIFICATIONS

INPUT VOLTAGE:	230V- 240V AC 50Hz (Other voltages available upon request e.g. 110V AC 60Hz)
TRANSFORMER PRIMARY VOLTAGE:	230V / 240VAC
SECONDARY VOLTAGE:	24V AC 100 VA
CONTROLLER VOLTAGE:	24V DC
MAXIMUM DOOR OPENING:^{1,2}	WIDTH: 5100mm
	HEIGHT: 3100mm
RATED LOAD:	200N
OPENER OPENING/CLOSING LIMITS TRAVEL:	3.5 Turns of Door Drum Wheel
OPENER MAXIMUM OPENING/CLOSING RUN TIME:	30 Secs.
RECEIVER TYPE:	UHF 433.92 MHz. AM Receiver
RECEIVER CODE STORAGE CAPACITY:	27 x 4 Button Transmitter Codes
TRANSMITTER FREQUENCY:	433.92 MHz
CODING TYPE:	Code Hopping
No. of CODE COMBINATIONS:	Over 4.29 Billion Random Codes
CODE GENERATION:	Non-linear Encryption Algorithm
PTX-4 TRANSMITTER BATTERY:	A23 Alkaline 12 Volts
EAT-1 TRANSMITTER BATTERY:	CR1220 Lithium 3 Volts
MOTOR TYPE:	Permanent Magnet Direct Current
MOTOR VOLTAGE:	24V DC
GLOBE:	Festoon Type - 15w 24V DC

- Note:**
- The maximum Roll Up Door (Domestic) opening that the EasyRoller can be installed on is 5100mm wide by 3100mm high. The door must be well balanced. A person should be able to lift the door up manually with very little effort in case of an emergency.
 - Intermittent operations may occur in areas which experience very strong winds. The strong wind puts extra pressure on the door and tracks which may in turn trigger the safety obstruction detection system intermittently.

TROUBLE SHOOTING

SYMPTOM	POSSIBLE CAUSE	REMEDY
Door will not operate.	Mains power not switched on. Door is obstructed. Door is locked or motor jammed. Door tracks/hardware damaged.	Switch on mains power. Remove obstruction. Unlock door or remove jam. Door requires service/repair by qualified technician.
Door starts to close but automatically reverses to open position.	Adverse weather conditions (wind or cold) causing door to stiffen and become tight in the tracks. Possible obstruction in the doorway.	Increase force margin setting and/or re-initialise the door. See Step 8 on page 11. Remove obstruction.
Door operates from drive unit (O/S/C) button but not from transmitter.* See note.	Transmitter code not stored in memory. Flat Battery.	Code transmitter in to openers memory. Refer Step 8.1 on page 14. Replace battery - A23 Alkaline 12V.
Door will not close fully.	Door limit positions need to be reset.	Reset limit positions. See Step 6 Page 10.
Door will not open fully.	Door limit positions need to be reset.	Reset limit positions. See Step 6 Page 10.
Courtesy light not working.	Globe blown.	Replace globe - festoon type 15W 24V DC.
Globe keeps blowing.	Incorrect globe voltage - must be 24V DC.	Replace globe - festoon type 15W 24V DC.
Auto close not working.	PE Beam or wiring faulty PE Beam not aligned correctly. PE Beam is obstructed. Door obstructed when closing. Auto close time not set.	Repair PE Beam or replace wiring. Re-align optics. Remove obstruction from the path of PE. Remove obstruction. See Step 15 on page 16.

***Please Note:** Some areas may be prone to excessive radio interference brought on by devices such as cordless telephones, wireless stereo headphones and baby monitors. It is possible that these devices could cause a degree of interference such as to greatly reduce the range of the transmitter. In such an instance please contact your ATA dealer for an alternative frequency replacement kit. As this is not a warrantable situation but an environmental issue charges may apply for the changeover.

DATE	MAINTENANCE PERFORMED BY	SIGNATURE	AMOUNT	INV. No.

Please Note: Failure to maintain your garage door may void the warranty for your garage door opener.

SPARE PARTS LIST

ITEM NO.	DESCRIPTION	ORDER CODE
1	LIMITS ASSY GDD-4	01680
2	LIMITS BASE	16260
3	ADJUSTMENT SCREW GREEN/RED	16300/16280
4	SWITCH HOLDER GREEN/RED	16340/16320
5	E CIRCLIP D1500 0040	10830
6	MINATURE MICROSWITCH	09280
7	DISENGAGEMENT SPRING	12360
8	MOTOR BASE	04430
9	CAM	04870
10	DISENGAGEMENT LEVER	16400
11	DISENGAGEMENT SHAFT	16140
12	CAM SPRING	12391
13	LIMITS CAM GUIDE	04920
14	LIMIT CAM GREEN-LIMIT CAM RED	04910/04900
15	PLASTIC BASE	16200
16	CLAMP	16000
17	GEAR MOTOR ASSY 710-2	00367
18	WDRM SHAFT 2	16100
19	GEAR	04460
20	LIMITS SHAFT	16120
21	BOARD SUPPORT	16220
22	HELICAL GEAR 2610	04091
23	INTERNAL GEAR	16020
24	MAIN COVER	16250
25	LIGHT DIFFUSER	05120
26	BOARD COVER	16241
27	CONTROL BOARD CB-7 V-4.01	00845
28	WDRM SUPPORT	16361
29	LIMITS BUSH	04340
30	CONTROLS LABEL	13581
31	LOGG LABEL RIGHT	13530
32	CLAMP ASSY GDD-4	01500
33	E RING M6	10812
34	CAPACITOR POLYFILM 01 UF X 2 275 VAC	07575
35	DISENGAGEMENT CAP	04410
36	SERRATED HD SCREW W/WASHER M4x12	10361
37	TRANSFORMER 100VA-05544 TDB-100-03	05544
37A	TRANSFORMER TDB-100-03 KIT	02020
38	TERMINAL BLOCK 500/02D5 2 PDS	05421
39	CORD GRIP GROMMET SB-GR-3	05600
40	EASY ACCESS TRANSMITTER PACK GDD-4	01237
41	HEX HEAD SCREW M8x25	10110
42	HEX FLANGE HD SCREW M6x16	10170
43	PAN SERRATION HD SCREW M4X12	10380
44	TAPTITE SCREW "P" M4X10	10570
45	TAPTITE SCREW "P" BLACK ZNC M3X16	10590
46	BUTTON HD SCREW W/WASHER M6x16	10022
47	PAN HD SCREW M3x10	15380
48	HEX FLANGE NUT M6	10150
49	RETAINING RING STW 45	10690
50	E CIRCLIP D1500 0080	10810
51	HEX NUT M4	10890
52	LITHIUM BATTERY 3V	13020
53	CLAMP WASHER	11180
54	SPECIAL WASHER	10620
55	FLAT WASHER I.D.5	11050
56	HEX NUT W/INT TOOTH WASHER M5	10881
57	IDENTITY LABEL	13591
58	WARNING LABEL	13710
59	STRING GUIDE	16420
60	PINION 122523	04162
60A	SELF LOCK EXT WASHER 706-2	10738
61	CABLE CLAMP ACC-2.5 (5/16")	11760
62	MICROSWITCH CX HARNESS	14280
63	POWER CORD 1.5M W/PIN+1 RING	14150
64	LOGG LABEL LEFT	13380
65	CORD LABEL	10690
66	TAPTITE SCREW "P" M3.5X10	10582
67	TAPTITE SCREW "P" M4X6	10259
68	HEX HEAD SCREW M6x35	10960
69	SPRING WASHER M6	04888
70	WASHER RUBBER 58.8x8.8x1	11169
71	WASHER CUP 55.5x7.2x7Hx1T	10875
72	HEX NUT M6	15290
73	SEL-LOK SPRING PIN Ø2.5x14	16366
74	SENSOR DISC	01690
75	SENSOR ASSY	04231
76	GEARBOX COVER 7	04072
77	HELICAL GEAR 6510-3 CX ASSY	15440
78	GLOBE 24V/15W 15x44	05440
79	TRANSMITTER RB PTX-4	01211
80	TRANSMITTER GB PTX-4	01210
80A	ENCLOSURE GBR PTX	05203
80B	TAPTITE SCREW "P" M2x8	10564
81	PTX HOLDER	05196
82	PLASTIC WALL PLUG PACK	10479
83	ALKALINE BATTERY A23 12V	13030
84	SECURACODE PTX-4 & W/S PACK	01220

WHEN ORDERING SPARE PARTS
PLEASE QUOTE THE ORDER
CODE NUMBER TO YOUR YOUR
INSTALLER/DISTRIBUTOR

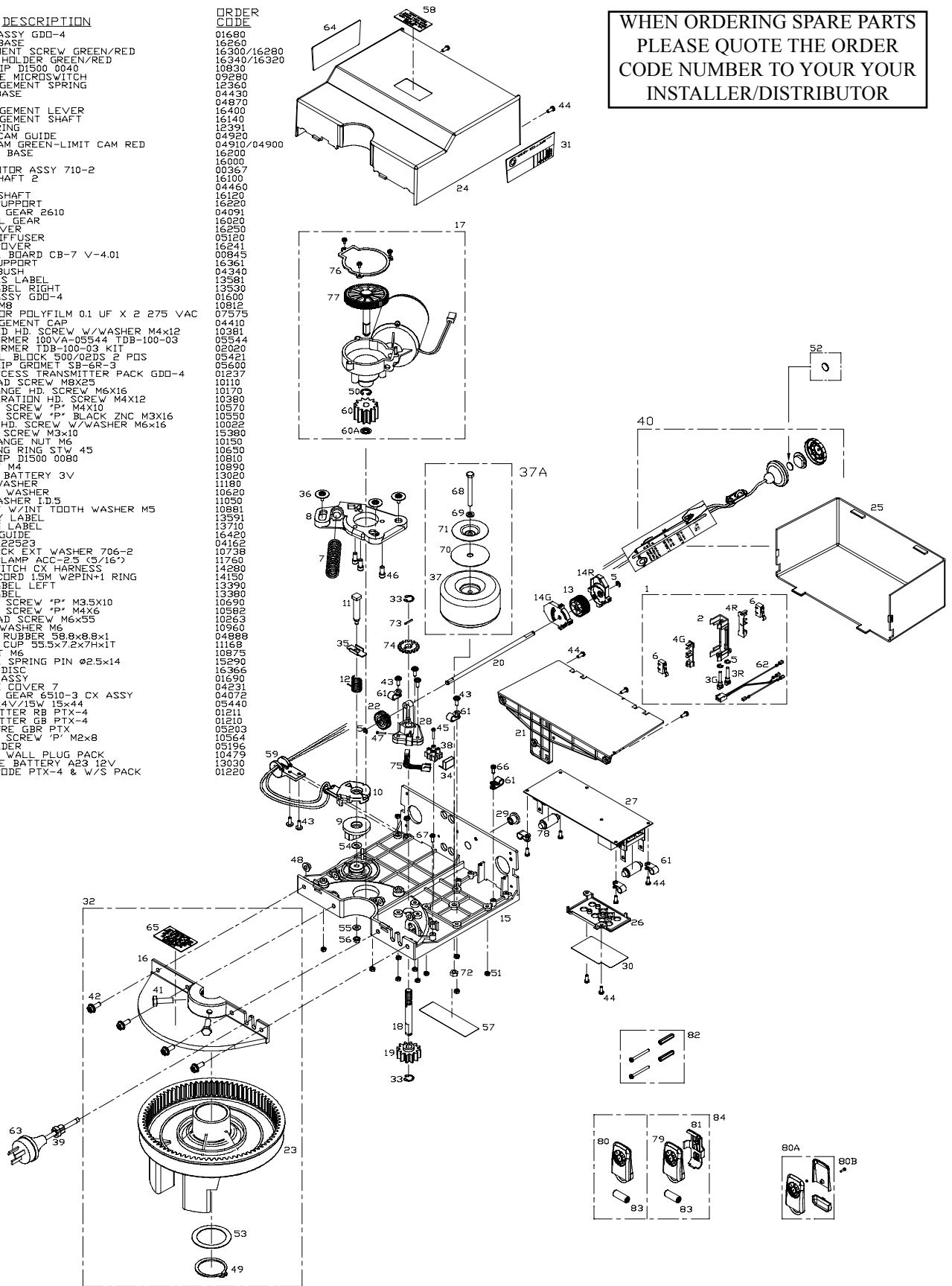

WARRANTY AND EXCLUSION OF LIABILITY

Subject to all of the matter set out below, Automatic Technology Australia Pty Ltd ("ATA") warrants for twenty four (24) months from the date of purchase (specified in the receipt sales docket) that the Garage Door Opener System contained in the accompanying packaging (the "Product") is free of any defects in material and workmanship rendering it unmerchantable.

This warranty referred to above applied only where:

- a) the consumer seeking to rely on the said warranty;
 - 1) returns the Product which it claims to be defective; and
 - 2) presents the relevant sales docket and this warranty document, to the retailer from whom the Product was purchased to confirm that date of purchase; and
- b) the purchaser notified ATA or the retailer from whom the Product was purchased of the alleged defect in the Product immediately upon experience or learning of the alleged defect.

Except for the warranty against defects in material and workmanship set out above, ATA gives no warranties of any kind whatsoever, whether express or implied or whether statutory or at common law, in relation to the Product, and all warranties of fitness for particular purpose and other warranties of whatsoever kind relating to the Product are hereby disclaimed. Without limiting the generality of the foregoing, ATA disclaims any liability of whatsoever nature in respect of any claim or demand loss or damage which arise out of;

- a) accidental damage to or normal wear and tear to the Product or to the Product's components;
- b) flood, rain, water, fire or lightning;
- c) incorrect, improper or unreasonable maintenance and/or use;
- d) installation, adjustment or use other than ATA which is not in accordance with the instructions set out in installation instructions incorporated in the document;
- e) attempted or complete modification or repairs to the Product carried out by a person who is not authorised by ATA to carry out such modification or repairs;
- f) faulty or unsuitable wiring of structure to which the Product is fixed or connected; and
- g) radio (including citizen band transmission) or any electronic interference.
- h) blown fuses or damage caused by electrical surges.
- i) damage caused by insects.
- j) lack of proper maintenance and care for the garage door and garage door opener. Failure to have the door serviced annually may void this warranty.
- k) installation of the opener on a commercial or industrial door or in a commercial or industrial situation.

ATA's liability under the warranty set out above is limited, at ATA's absolute option, to replacing or repairing the Product which ATA, in its unfettered opinion, considers to be defective either in material and/or workmanship or to credit the consumer with the price at which the Product was purchased by the consumer.

Where the Product is retailed by any person other than ATA, except for the warranty set out above, such person has no authority from ATA to give any warranty or guarantee on ATA's behalf in addition to the warranty set out above.

Purchased From _____	Phone _____
Installed By _____	Date _____
Serial No. _____	

AUTOMATIC TECHNOLOGY AUSTRALIA PTY LTD

ABN 11 007 125 368

17-19 Advantage Rd, Highett, Victoria, Australia 3190

Tel: +61 3 9532 2788 Fax: +61 3 9532 2799

Web: www.ata-aust.com.au Email: sales@ata-aust.com.au